

SERVICE MANUAL

LE-4A CHASSIS

MODEL	COMMANDER	DEST	CHASSIS NO.	MODEL	COMMANDER	DEST	CHASSIS NO.
KF-50SX300	RM-906	AEP	SCC-R01A-A	KF-60SX300	RM-906	AEP	SCC-R01B-A
KF-50SX300K	RM-906	OIRT	SCC-R03A-A	KF-60SX300K	RM-906	OIRT	SCC-R03B-A
KF-50SX300U	RM-906	UK	SCC-R02B-A	KF-60SX300U	RM-906	UK	SCC-R02A-A



KF-50/60SX300



RM-906

LCD PROJECTION TV
SONY®

TABLE OF CONTENTS

Section	Title	Page	Section	Title	Page
	Caution	3	5. DIAGRAMS		
	Specifications	4	5-1.	Block Diagram (1)	31
	Connectors	5		Block Diagram (2)	32
				Block Diagram (3)	33
				Block Diagram (4)	34
1. SELF DIAGNOSIS FUNCTION			5-2.	Circuit Boards Location	34
	LE-4A Self Diagnostic Software	6	5-3.	Schematic Diagrams and Printed Wiring Boards	34
2. GENERAL		7		A Board Schematic Diagram	35
				A Printed Wiring Board	38
3. DISASSEMBLY				B Board Schematic Diagram	39
3-1.	Rear Cover Removal	21		B Printed Wiring Board	42
3-2.	Centre Pillar Removal	21		C Board Schematic Diagram	43
3-3.	Service Position	21		C Printed Wiring Board	47
3-4.	Chassis, Optical Unit, DC Fan Removal	21		J Board Schematic Diagram	49
3-5.	Power Block Removal	22		J Printed Wiring Board	50
3-6.	H1 Board Removal	22		G Board Schematic Diagram	51
3-7.	H2 Board Removal	22		G Printed Wiring Board	52
3-8.	H3 Board Removal	22		H1 Schematic Diagram	53
3-9.	A Board Removal	23		H1 Printed Wiring Board	52
3-10.	G Board Removal	23		H2 Board Schematic Diagram	53
3-11.	T Board Removal	23		H2 Printed Wiring Board	52
3-12.	Front Panel Removal	23		H3 Board Schematic Diagram	53
3-13.	Front Cover Removal	24		H3 Printed Wiring Board	52
3-14.	Control Panel Removal	24		T Board Schematic Diagram	53
3-15.	Screen, Mirror Block Assembly Removal	24		T Printed Wiring Board	52
3-16.	Mirror Cover Block Assembly Removal	25	5-4.	Semiconductors	54
3-17.	Contrast Screen, Diffusion Plate Removal	25	5-5.	IC Block Diagrams	56
3-18.	Woofers Block Assembly Removal	26			
3-19.	Speaker Removal	26	6. EXPLODED VIEWS		
3-20.	Mirror Removal	26	6-1.	Screen and Cover Block	58
4. ELECTRICAL ADJUSTMENTS			6-2.	Cabinet Block	59
4-1.	Adjustments with Commander	27	6-3.	Main Bracket Block	60
4-1-1.	How to Select Each Mode	27	6-4.	Picture Tube Block	61
4-1-2.	Programming the Remote Commander for Operation in Service Mode	27	7. ELECTRICAL PARTS LIST		62
4-1-3.	Setting the TV into Service Mode	27			
4-1-4.	Screen Display for Service Menu	27			
4-1-5.	Operation Method for Adjustments	29			
4-2.	Screen Centre Adjustment	29			
4-3.	Test Test Mode	29			

WARNING !!

AN ISOLATION TRANSFORMER SHOULD BE USED DURING ANY SERVICE WORK TO AVOID POSSIBLE SHOCK HAZARD DUE TO LIVE CHASSIS, THE CHASSIS OF THIS RECEIVER IS DIRECTLY CONNECTED TO THE POWER LINE.

SAFETY-RELATED COMPONENT WARNING !!

COMPONENTS IDENTIFIED BY SHADING AND MARKED Δ ON THE SCHEMATIC DIAGRAMS, EXPLODED VIEWS AND IN THE PARTS LIST ARE CRITICAL FOR SAFE OPERATION. REPLACE THESE COMPONENTS WITH SONY PARTS WHOSE PART NUMBERS APPEAR AS SHOWN IN THIS MANUAL OR IN SUPPLEMENTS PUBLISHED BY SONY.

CAUTION

Lead Free Soldered Boards

The circuit boards listed below [Table 1] used in these models may have been processed using Lead Free Solder. The boards are identified by the LF logo located close to the board designation e.g. F1, H1 etc [see examples]. The servicing of these boards requires special precautions to be taken as outlined below.



Table 1

Board	Function
A	Tuner, Audio, Regulators
B	Micro, 3D Comb
C	Scanrate, Backend, Digital Gamma, LCD Drivers
G	Power Supply
H1	User Key, Sirco
H2	LED Indicators
H3	AV Input, HP Out
J	A/V Switch
T	Lamp Cover Switch

example 1

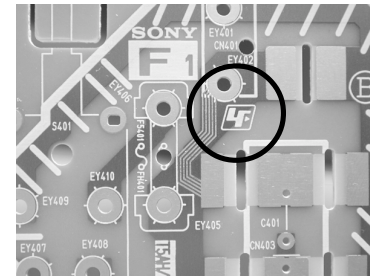

example 2



It is strongly recommended to use Lead Free Solder material in order to guarantee optimal quality of new solder joints. Lead Free Solder is available under the following part numbers :

Partnumber	Diameter	Remarks
7-640-005-19	0.3mm	0.25Kg
7-640-005-20	0.4mm	0.50Kg
7-640-005-21	0.5mm	0.50Kg
7-640-005-22	0.6mm	0.25Kg
7-640-005-23	0.8mm	1.00Kg
7-640-005-24	1.0mm	1.00Kg
7-640-005-25	1.2mm	1.00Kg
7-640-005-26	1.6mm	1.00Kg

Due to the higher melting point of Lead Free Solder the soldering iron tip temperature needs to be set to 370 degrees centigrade. This requires soldering equipment capable of accurate temperature control coupled with a good heat recovery characteristics.

For more information on the use of Lead Free Solder, please refer to <http://www.sony-training.com>

ITEM MODEL	Television System	Stereo System	Channel Coverage	Color System
AEP	B/G/H, D/K, I, L	GERMAN/NICAM Stereo	VHF : E02-12 UHF : E21-69 CABLE TV : S1-S20 HYPER : S21-S41 D/K: R1-12, R21-69 L: F02-10 , B-Q , F21-F69 I: B21-69 I: B21-69	PAL, SECAM NTSC3.58, NTSC4.43 (VIDEO IN)
OIRT	B/G/H, D/K	GERMAN/NICAM Stereo	VHF : E02-12 UHF : E21-69 CABLE TV : S1-S20 HYPER : S21-S41 D/K: R1-12, R21-69	PAL, SECAM NTSC3.58, NTSC4.43 (VIDEO IN)
UK	I	NICAM Stereo	UHF : B21-B69	PAL, SECAM NTSC3.58, NTSC4.43 (VIDEO IN)

Projected Picture Size	Approx 127 cm (50 inches) (Approx 127 cm picture measured diagonally) KF-50SX300 Approx 153 cm (60 inches) (Approx 153 cm picture measured diagonally) KF-60SX300	Sound Output	
		Right and Left speaker	2x20W (Music Power) 2x10W (RMS)
		Subwoofer	1x30W (Music Power) 1x15W (RMS)
Input/Output Terminals [REAR]		General Specifications	
1: 21-pin Euro connector (CENELEC standard)	Inputs for Audio and Video signals. Inputs for RGB. Outputs of TV Video and Audio signals.	Power Requirements	220 - 240V
		Power Consumption/ Standby	Approx 210W/<1W (KF-50SX300) Approx 210W/<1W (KF-60SX300)
2: 21-pin Euro connector (CENELEC standard)	Inputs for Audio and Video signals. Inputs for RGB. Outputs of Monitor Video and Audio signals.	Dimensions	Approx 1376 x 923 x 442MM (KF-50SX300) Approx 1618 x 1062 x 542mm (KF-60SX300)
		Weight	Approx 37.5kg (KF-50SX300) Approx 48.5kg (KF-60SX300)
3: 21-pin Euro connector (CENELEC standard)	Inputs for Audio and Video signals. Inputs for S Video. Outputs for Video and Audio signals (selectable). Smartlink interface.	Supplied Accessories	RM-906 Remote Commander (1) IEC designated R6 battery (2)
Phono Jacks	Output Connectors variable for Audio Signals.	Other Features	Digital Comb Filter, Teletext, NextView, PAP, Smartlink, Virtual Dolby, Digital BBE, NICAM, ACI, TV system autodetection.
Minijack	Input for PC Audio.		
D type connector	PC input.		
Input/Output Terminals [FRONT]		Remote control system : Infrared control	
Headphone jack	stereo mini jack	Power requirements	3V dc 2 batteries IEC designation LR03 (size AAA)
Audio inputs	phono jacks		
Video inputs	phono jacks		
S Video input	4 pin DIN		
Design and specifications are subject to change without notice.			

Model Name Item	KF-50/60SX300AEP	KF-50/60SX300K	KF-50/60SX300U
Pal Comb	ON	ON	ON
PAP	ON	ON	ON
RGB Priority	ON	ON	ON
Woofer Box	ON	ON	ON
Scart 1	ON	ON	ON
Scart 2	ON	ON	ON
Scart 3	ON	ON	ON
Front in (4)	ON	ON	ON
Projector	ON	ON	ON
Norm B/G	ON	ON	OFF
Norm I	ON	OFF	ON
Norm D/K	ON	ON	OFF
Norm AUS	OFF	OFF	OFF
Norm L	ON	OFF	OFF
Norm SAT	OFF	OFF	OFF
Norm M	OFF	OFF	OFF
Teletext	ON	ON	ON
Nicam	ON	ON	ON

WARNING (UK Models only)

The flexible mains lead is supplied connected to a **B.S. 1363** fused plug having a fuse of **5 AMP** rating. Should the fuse need to be replaced, use a **5AMP FUSE** approved by ASTA to **BS 1362**, ie one that carries the  mark.

IF THE PLUG SUPPLIED WITH THIS APPLIANCE IS NOT SUITABLE FOR THE OUTLET SOCKETS IN YOUR HOME, IT SHOULD BE CUT OFF AND AN APPROPRIATE PLUG FITTED. THE PLUG SEVERED FROM THE MAINS LEAD MUST BE DESTROYED AS A PLUG WITH BARED WIRES IS DANGEROUS IF ENGAGED IN A LIVE SOCKET.

When an alternative type of plug is used, it should be fitted with a **5 AMP FUSE**, otherwise the circuit should be protected by a **5AMP FUSE** at the distribution board.

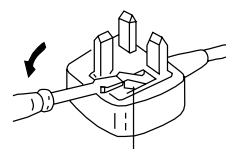

How to replace the fuse.
Open the fuse compartment with a screwdriver blade and replace the fuse.

FUSE

21 pin connector

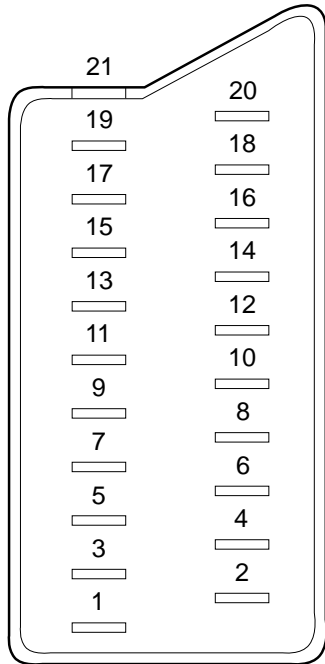

Pin No	1	2	3	Signal	Signal level
1	○	○	○	Audio output B (right)	Standard level : 0.5V rms Output impedance : Less than 1kohm*
2	○	○	○	Audio input B (right)	Standard level : 0.5V rms Output impedance : More than 10kohm*
3	○	○	○	Audio output A (left)	Standard level : 0.5V rms Output impedance : Less than 1kohm*
4	○	○	○	Ground (audio)	
5	○	○	○	Ground (blue)	
6	○	○	○	Audio input A (left)	Standard level : 0.5V rms Output impedance : More than 10kohm*
7	○	●	●	Blue input	0.7 +/- 3dB, 75 ohms positive
8	○	○	○	Function select (AV control)	High state (9.5-12V) : Part mode Low state (0-2V) : TV mode Input impedance : More than 10K ohms Input capacitance : Less than 2nF
9	○	○	○	Ground (green)	
10	○	○	○	Open	
11	○	●	●	Green	Green signal : 0.7 +/- 3dB, 75 ohms, positive
12	○	○	○	Open	
13	○	○	○	Ground (red)	
14	○	○	○	Ground (blanking)	
15	○	-	-	Red input	0.7 +/- 3dB, 75 ohms, positive
	-	○	○	(S signal Chroma input)	0.3 +/- 3dB, 75 ohms, positive
16	○	●	●	Blanking input (Ys signal)	High state (1-3V) Low state (0-0.4V) Input impedance : 75 ohms
17	○	○	○	Ground (video output)	
18	○	○	○	Ground (video input)	
19	○	○	○	Video output	1V +/- 3dB, 75ohms, positive sync 0.3V (-3+10dB)
20	○	-	-	Video input	1V +/- 3dB, 75ohms, positive sync 0.3V (-3+10dB)
	-	○	○	Video input Y (S signal)	1V +/- 3dB, 75ohms, positive sync 0.3V (-3+10dB)
21	○	○	○	Common ground (plug, shield)	

○ Connected ● Not Connected (open) * at 20Hz - 20kHz

Rear Connection Panel



Front Connection Panel



S-Video socket

S Video socket pin configuration		
Pin No	Signal	Signal Level
1	Ground	-
2	Ground	-
3	Y (S signal) input	1V +/- 3dB 75ohm, positive Sync. 0.3V -3 +10dB
4	C (S signal) input	0.3V +/- 3dB 75ohm, positive Sync.

SECTION 1 SELF DIAGNOSIS FUNCTION

LE-4A Self Diagnostic Software

The identification of errors within the LE-4A chassis is triggered in one of two ways :- 1: Busy or 2: Device failure to respond to IIC. In the event of one of these situations arising the software will first try to release the bus if busy (Failure to do so will report with a continuous flashing LED) and then communicate with each device in turn to establish if a device is faulty. If a device is found to be faulty the relevant device number will be displayed through the LED (Series of flashes which must be counted) See table 1, non fatal errors are reported using this method. Each time the software detects an error it is stored within the NVM. See Table 2.

Table 1

Error Message	LED Code
Lamp Cov	02
Lamp Prot	03
Fan Prot	04
Temp Prot	05
IIC	06
NVM	07
Tuner	09
Sound	10
Scanrate	12
Backend	14
AVSwitch	17
Digital Gamma	22
LCD Drivers	23
Speaker Prot	24

How to enter into Table 2

1. Turn on the main power switch of the TV set.
2. Program Remote Commander for Operation in Service Mode. [See Page 27].
3. Press 'VIDEO' 'VIDEO' > 'MENU' on the Remote Commander.
4. Using the Remote Commander, Scroll to the 'Error Menu' item using the down arrow key, then press the right arrow key.
5. The following table will be displayed indicating the error count.

Table 2

Error monitor		
WORKING TIME:	(Hours:Minutes)	82:33
Error counters:		
E02: LAMP COV		45
E03: LAMP PROT		8
E04: FAN PROT		55
E05: TEMP PROT		0
E06: IIC		0
E07: NVM		0
E09: TUNER		2
E10: SOUND		0
E12: SCANRATE		4
E14: BACKEND		2
E17: AVSWITCH		10
E22: DIGITAL GAMMA		3
E23: LCD Drivers		6
E24: SPEAKER PROT		0
Select: ▲ ▼	Previous Menu: ◀	

Flash Timing Example : e.g. error number 3

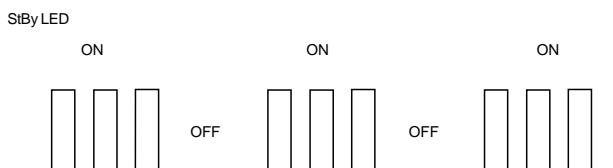

Note: To clear the error count data press '80' on the Remote commander.

SECTION 2 GENERAL

The operating instructions mentioned here are partial abstracts from the Operating Instruction Manual. The page numbers of the Operating Instruction Manual remain as in the manual.

Checking the Accessories supplied



1 Remote control (RM-906)

Inserting Batteries into the Remote Control

Make sure you insert the supplied batteries using the correct polarities. Always remember to dispose of used batteries in an environmental friendly way.

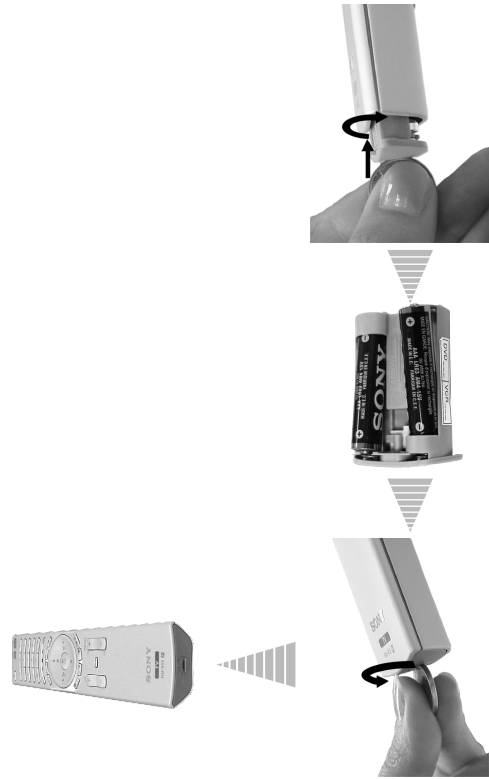

Overview of Remote Control Buttons

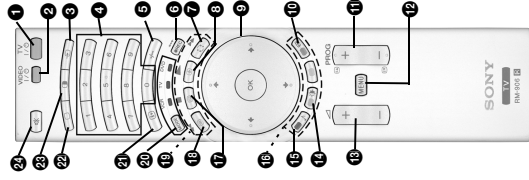

- 1 **TV I/O**: To temporarily switch off TV (standby mode): Press this button to temporarily switch off TV (the standby indicator ϕ on the TV lights up). Press again to switch on TV from standby mode.
 - To save energy we recommend switching off completely when TV is not in use.
 - After 15 minutes without TV signal and without any button being pressed, the TV switches automatically into standby mode.
- 2 **VCR or DVD on/off**: press this button to switch your VCR or DVD on or off.
- 3 **Selecting input source**: press this button repeatedly until the desired input symbol of the source appears on the TV screen. Refer to page 25.
- 4 **Selecting broadcast channels**: if Media Selector (20) is switched to TV, press these buttons to select channels. For double-digit programme numbers, enter the second digit within 2.5 seconds.
- 5 **Selecting VCR double-digit**: if Media Selector (20) is switched to VCR, press this button to select double-digit channels for Sony's VCR e.g. 23, press +/- first and next the buttons 2 and 3.
- 6 a) **Recording button**: if Media Selector (20) is switched to VCR, press this button to record programmes.
 b) **Resetting to factory set levels**: Press, for a minimum of 3 seconds, to return the picture and sound settings to the factory default levels. This will also return the set to the initial condition and the "Auto Tuning" menu will appear on the screen. If this is the case refer to the section "Switching on the TV set and automatically Tuning" (page 11, step 5) of this manual.
- 7 **Watching last channel selected**: if Media Selector (20) is switched to TV, press this button to return to the previous channel you were watching (provided you watched it for at least 5 seconds).
- 8 **Freezing a teletext page**: in teletext mode, press this button to freeze a teletext page. Press it again to cancel the freeze.
- 9 a) **Displaying a channel index**: if Media Selector (20) is switched to TV and MENU is switched off, press OK to display a channel overview. If you want to select a channel, press \blacktriangleright or \blacktriangleleft next press again the OK button to watch the selected channel.
 b) **Navigator**: if Media Selector (20) is switched to TV and MENU (12) is switched on, use these buttons to navigate through the menu system of the TV. Refer to page 12.
- 10 **Selecting the screen format**: press this button repeatedly to change the format of the screen. Refer to page 16.
- 11 **Selecting broadcast channels**: press these buttons to select the next or previous broadcast channel.
- 12 **Menu system**: press this button to enter the TV menu system. Refer to page 12.
- 13 **Adjusting volume**: press these buttons to increase or decrease the audio volume.
- 14 **Selecting picture mode**: press this button repeatedly to change the picture mode. For details on the different picture modes, refer to page 13.
- 15 **Selecting the sound effect**: Press this button repeatedly to change the sound effect. For details on different sound effects, refer to page 14.
- 16 **Fastext**: In Teletext mode, these buttons can be used as Fastext buttons. For details see page 22.
- 17 **NexTVView**: press this button to display NexTVView. For details, refer to page 23.
- 18 **Teletext**: press this button to switch on Teletext. For details see page 22.
- 19 **Operating VCR or DVD**: if Media Selector (20) is switched to VCR or DVD, these buttons will operate the main functions of your VCR or DVD, once the remote control has been programmed. Refer to page 26.
- 20 **Media Selector**: press this button to select which device you want to operate, TV, VCR or DVD. A green light will be momentarily lit to show which one you have selected. For details refer to page 26.
- 21 **Displaying info**: press this button to display all on-screen indication such as channel number, etc. Press again to cancel.
- 22 **Selecting TV mode**: press this button to switch off PAP, Teletext or Video input mode.
- 23 **PAP (Picture And Picture)**: press this button to divide the screen into two for watching two channels simultaneously. Refer to page 21.
- 24 **Muting the sound**: press this button to mute the TV sound. Press again to restore the sound.

Overview of Remote Control Buttons

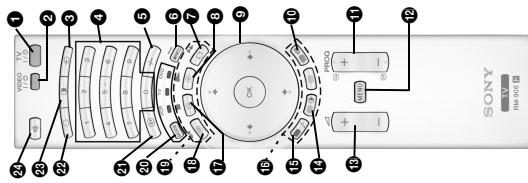

- 1 **TV I/O**: To temporarily switch off TV (standby mode): Press this button to temporarily switch off TV (the standby indicator \odot on the TV lights up). Press again to switch on TV from standby mode.
 - To save energy, we recommend switching off completely when TV is not in use.
 - After 15 minutes without TV signal and without any button being pressed, the TV switches automatically into standby mode.
- 2 **VCR or DVD on/off**: press this button to switch your VCR or DVD on or off.
- 3 **Selecting input source**: press this button repeatedly until the desired input symbol of the source appears on the TV screen. Refer to page 25.
- 4 **Selecting broadcast channels**: if Media Selector (20) is switched to TV, press these buttons to select channels. For double-digit programme numbers, enter the second digit within 2.5 seconds.
- 5 **Selecting VCR double-digit**: if Media Selector (20) is switched to VCR, press this button to select double-digit channels for Sony's VCR e.g. 23, press -/-- first and next the buttons 2 and 3.
- 6 **a) Recording button**: If Media Selector (20) is switched to VCR, press this button to record programmes.
b) Resetting to factory set levels: Press, for a minimum of 3 seconds, to return the picture and sound settings to the factory/default levels. This will also return the set to the install condition and the "Auto Tuning" menu will appear on the screen. If this is the case refer to the section "Switching on the TV set and automatically Tuning" (page 11, step 5) of this manual.
- 7 **Watching last channel selected**: if Media Selector (20) is switched to TV, press this button to return to the previous channel you were watching (provided you watched it for at least 5 seconds).
- 8 **Freezing a teletext page**: in teletext mode, press this button to freeze a teletext page. Press it again to cancel the freeze.
- 9 **a) Displaying a channel index**: if Media Selector (20) is switched to TV and MENU is switched off, press **OK** to display a channel overview. If you want to select a channel, press \blacktriangleright or \blacktriangleleft next press again the **OK** button to watch the selected channel.
b) Navigator: if Media Selector (20) is switched to TV and MENU (19) is switched on, use these buttons to navigate through the menu system of the TV. Refer to page 12.
- 10 **Selecting the screen format**: press this button repeatedly to change the format of the screen. Refer to page 16.
- 11 **Selecting broadcast channels**: press these buttons to select the next or previous broadcast channel.
- 12 **Menu system**: press this button to enter the TV menu system. Refer to page 12.
- 13 **Adjusting volume**: press these buttons to increase or decrease the audio volume.
- 14 **Selecting picture mode**: press this button repeatedly to change the picture mode. For details on the different picture modes. Refer to page 13.
- 15 **Selecting the sound effect**: Press this button repeatedly to change the sound effect. For details on different sound effects. Refer to page 14.
- 16 **Fastext**: In Teletext mode, these buttons can be used as Fastext buttons. For details see page 22.
- 17 **NexTVView**: press this button to display NexTVView. For details. Refer to page 23.
- 18 **Teletext**: press this button to switch on Teletext. For details see page 22.
- 19 **Operating VCR or DVD**: if Media Selector (20) is switched to VCR or DVD, these buttons will operate the main functions of your VCR or DVD, once the remote control has been programmed. Refer to page 26.
- 20 **Media Selector**: press this button to select which device you want to operate, TV, VCR or DVD. A green light will be momentarily lit to show which one you have selected. For details refer to page 26.
- 21 **Displaying info**: press this button to display all on-screen indication such as channel number, etc. Press again to cancel.
- 22 **Selecting TV mode**: press this button to switch off PAP, Teletext or Video input mode.
- 23 **PAP (Picture And Picture)**: press this button to divide the screen into two for watching two channels simultaneously. Refer to page 21.
- 24 **Muting the sound**: press this button to mute the TV sound. Press again to restore the sound.

Connecting the Aerial and VCR

- 1 Connecting cables are not supplied.
- 2 For more details of VCR connections as well as other connections, please refer to page 24.

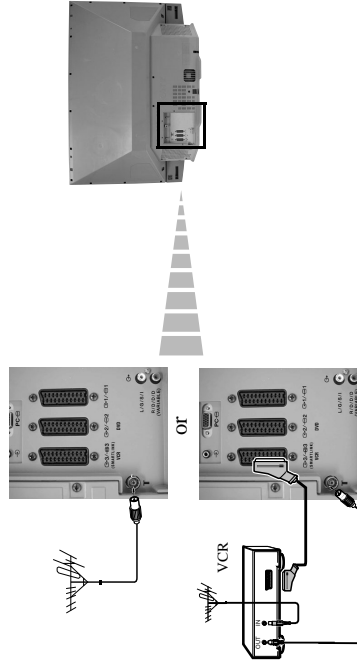

- 1 The Scart lead is optional. If you use this optional connection it can improve picture and sound quality when using a VCR.

- 2 If you do not use a Scart lead, you will need to manually tune the VCR to a spare channel once the autotune procedure has been completed. Refer to "Manual Programme Preset" on page 20. Also refer to your VCR instruction manual to find out how to find the output channel of your VCR.

Stabilizing the TV set

- 1 After setting up, secure the TV set to a wall, etc., using the supplied brackets and screws, for safety purposes.

- 1 Mount the two supplied brackets with the screws provided to the upper rear side of the TV set.

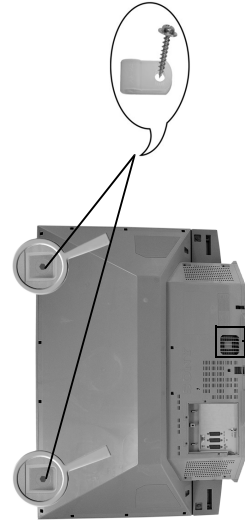

- 2 Do not block or cover this ventilation opening. For ventilation, leave a space of at least 10 cm from the wall.

- 2 Pass a strong cord or a chain through each bracket, and then secure to a wall or a pillar, etc.

Switching On the TV and Automatically Tuning

1 The first time you switch on your TV, a sequence of menu screens appear on the TV enabling you to: 1) choose the language of the menu screen 2) Choose the country in which you are going to operate the TV, 3) check how to connect optional equipment to your TV, 4) search and store all available channels (TV Broadcast) and 5) change the order in which the channels (TV Broadcast) appear on the screen. However, if you need to change any of these settings at a later date, you can do that by selecting the appropriate option in the **⊗** (Set Up menu).

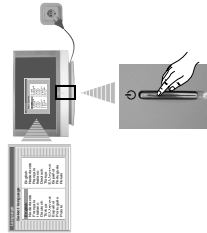

1 Connect the TV plug to the mains socket (220-240V AC, 50Hz). The first time that the TV set is connected, it is usually turned on. If the TV is off, press the **⊗** on/off button on the TV set to turn on the TV. The first time you switch on the TV, a **Language** menu displays automatically on the TV screen.

2 Press the **⬆** **⬇** **⬅** or **➡** buttons on the remote control to select your language, then press the **OK** button to confirm your selection. From now on all the menus will appear in your chosen language.

3 The **Country** menu appears automatically. Press the **⬆** or **⬇** button to select the country in which you are using the TV. Press the **OK** button to confirm your selection.

4 If the country in which you want to use the TV set does not appear in the list, select "off" instead of a country.
 • To avoid wrong teletext characters for Cyrillic languages we recommend selecting Russia country if your own country does not appear in the list.

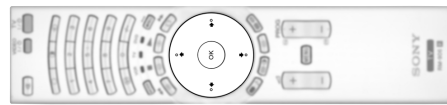

4 A diagram will appear showing you how to connect a wide range of equipment to your TV set. Follow the instructions and finally press the **OK** button to remove the picture and continue the automatic process.



5 After the automatic tuning process has finished and the optional equipment has been connected at this stage, we recommend you follow the instructions explained on the section "Connection Guide" on page 17 to get the optimum settings related with the optional equipment.

5 The **Auto Tuning** menu appears on the screen. Press the **OK** button to select **Yes**.



6 The TV starts to automatically search and store all available broadcast channels for you.

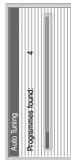

7 This procedure could take some minutes. Please be patient and do not press any buttons, otherwise automatic tuning will not be completed.

8 In some countries the TV Broadcaster installs the channels automatically (ACI system). In this case, the TV Broadcaster sends a menu in which you can select your city by pressing the **⬆** or **⬇** button and **OK** to store the channels.

9 If no channels were found during the auto tune process, a message appears automatically on the screen asking you to connect the aerial. Check the aerial connection (refer to page 9). Press the **OK** button to restart the auto tuning process.



7 After all available channels are captured and stored, the **Programme Sorting** menu automatically appears on the screen enabling you to change the order in which the channels are stored.

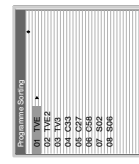

a) If you wish to keep the broadcast channels in the tuned order, go to step 8.

b) If you wish to store the channels in a different order:

- 1 Press the **⬆** or **⬇** button to select the programme number with the channel (TV Broadcast) you wish to move. Press the **➡** button.
- 2 Press the **⬆** or **⬇** button to select the new programme number position for your selected channel (TV Broadcast). Press the **OK** button to store.
- 3 Repeat steps b)1 and b)2 if you wish to change the order of the other channels.

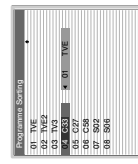

8 Press the **MENU** button to remove the menu from the screen

Your LCD TV is now ready for use

continued...

Introducing and Using the Menu System

i Your LCD TV uses an On-Screen menu system to guide you through the operations. Use the following buttons on the Remote Control to operate the menu system:

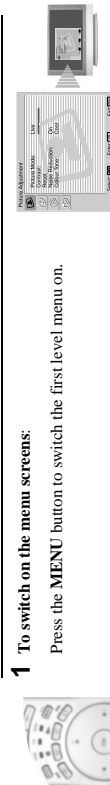

1 To switch on the menu screens:

Press the MENU button to switch the first level menu on.

2 To navigate through the menus:

- To highlight and select the desired menu or option, press **↵** or **⬅**.
- To enter the selected menu or option, press **OK** or **➡**.
- To return to the last menu or option, press **OK** or **⬅**.
- To alter the settings of your selected option, press **↵/➡/⬅** or **➡**.
- To confirm and store your selection, press **OK**.

3 To switch off the menu screens:

Press the MENU button to remove the menu from the screen.

The Picture Adjustment Menu

i The "Picture Adjustment" menu allows you to alter the picture settings.

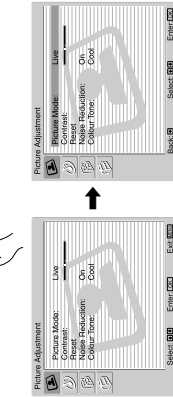

To do this:

Press the MENU button and then press **OK** to enter this menu. Next press **↵** or **➡** to select the desired option and press **OK**. Finally read below how to operate into each option.

Picture Mode

This option allows you to customise the Picture Mode based on the programme you are watching. After selecting this option press **OK**. Next press repeatedly **↵** or **➡** to select:

Personal (for individual settings).

Live (for live broadcast programmes, DVD and Digital Set Top Box receivers), **Movie** (for films).

Once you have selected your desired option, press **OK** to store.

i "Brightness", "Colour" and "Sharpness" level of "Live" and "Movie" mode are fixed on the factory to get the best picture quality.

Contrast Press **↵** or **➡** to reduce or enhance picture contrast. Next press **OK** to store.

Brightness Press **↵** or **➡** to darken or brighten the picture. Next press **OK** to store.

Colour Press **↵** or **➡** to decrease or to increase color intensity. Next press **OK** to store.

Hue Press **↵** or **➡** to decrease or to increase the green tones. Next press **OK** to store.

Sharpness Press **↵** or **➡** to soften or to sharpen the picture. Next press **OK** to store.

Reset Press **OK** to reset the picture to the factory preset levels.

Noise Reduction This option is set to **On** to automatically reduce the snowy picture visible in the broadcast signal. To cancel this function, press **↵** or **➡** to select **Off**.

Colour Tone This option allows you to alter the tint of the picture. After selecting this option press **↵**. Next press repeatedly **↵** or **➡** to select: **Warm** (gives the white colours a red tint), **Normal** (gives the white colours a neutral tint), **Cold** (gives the white colours a blue tint). Next press **OK** to store.

Lines Correction While viewing an RGB input signal from the PC connector, some picture lines may be not correctly displayed. To correct this problem, select this option and press **↵**. Next press repeatedly **↵** or **➡** to correct it between -20 and +20. Finally press **OK** to store.

- i**
- "Brightness" "Colour" and "Sharpness" only appears and only can be altered if "Picture mode" is set to "Personal".
 - "Hue" only appears and only can be altered for NTSC signal (e.g. USA video tapes).
 - For an RGB input signal connected to the PC connector, only appear and only can be altered: "Contrast", "Brightness" and "Lines Correction".

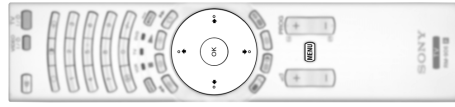

The Sound Adjustment Menu

 The "Sound Adjustment" menu allows you to alter the sound settings.

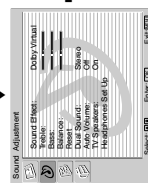
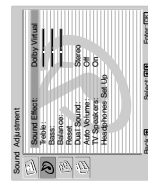
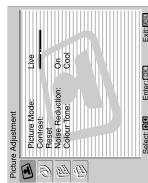

To do this:

Press the **MENU** button and press **▼** to select **Sound**, then press **OK** to enter this menu. Next press **▼** or **▲** to select the desired option and press **OK**. Finally read below how to operate into each option.

Sound Effect This option allows you to customise the Sound Effect. After selecting this option press **OK**. Next press repeatedly **▼** or **▲** to select:

- Off** (Flat response).
- Natural** (Enhances clarity, detail and presence of sound by using "BBE High Definition Sound system"*)
- Dynamic** ("BBE High Definition Sound system"*) intensifies clarity and presence of sound for better intelligibility and musical realism).
- Dolby**** (Dolby Virtual, simulates the sound effect of "Dolby Surround Pro Logic").

Once you have selected your desired option, press **OK** to store.

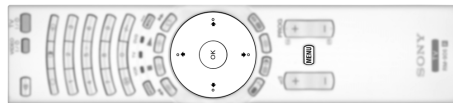

- Treble** Press **◀** or **▶** to decrease higher-frequency sounds. Next press **OK** to store.
- Bass** Press **◀** or **▶** to decrease or to increase the lower-frequency sounds. Next press **OK** to store.
- Balance** Press **◀** or **▶** to emphasise the left or the right speaker. Next press **OK** to store.
- Reset** Press **OK** to reset the sound to the factory preset levels. Next press **OK** to store.

- Dual Sound**
 - For a Stereo broadcast: Press **▼** or **▲** to select **Stereo** or **Mono**. Next press **OK** to store.
 - For a bilingual broadcast: Press **▼** or **▲** to select **Mono** (for mono channel if available), **A** (for channel 1) or **B** (for channel 2). Next press **OK** to store.

continued...



Auto Volume Press **▼** or **▲** to select **On** (the volume level of the channels will stay the same, independent of the broadcast signal, e.g. in the case of advertisements) or **Off** (the volume level changes according to the broadcast signal). Next press **OK** to store.

 If you select "Dolby Virtual" on the "Sound Effect" option, the "Auto Volume" option will automatically be switched to "Off" and vice versa.

TV Speakers This option allows you to select if you want to listen the TV from the TV speakers or from an external amplifier connected to the audio outputs on the rear of the TV. After selecting this option, press **OK**. Next press repeatedly **▼** or **▲** to select:

- On** (to listen the TV from the TV set speakers).
- One time off** (to listen to the TV from the external amplifier only one time. By using this option, any time the TV is turned off/on, it returns to the default setting "On").
- Permanent off** (to always listen to the TV from external amplifier).

Once you have selected your desired option, press **OK** to store.

 If you have selected "One time off" or "Permanent off", the volume of the external equipment can also be altered by pressing the +/- buttons of the remote control. When the volume buttons are pressed, the symbol  will appear indicating that the volume you are altering is not the volume of the TV set speakers, it is from the external equipment.

Headphones Set Up This option allows you to customise the headphones volume and the PAP settings (refer to page 21 for details on PAP).

- After selecting this option press **OK**. Next press repeatedly **▼** or **▲** to select:
- volume** Press **◀** or **▶** to decrease or increase the volume level from the headphones.
 - Dual Sound**
 - For a Stereo broadcast: Press **▼** or **▲** to select **Stereo** or **Mono**
 - For a bilingual broadcast: Press **▼** or **▲** to select **Mono** (for mono channel if available), **A** (for channel 1) or **B** (for channel 2).
 - PAP Sound** Select **Frame** if you want to listen to the active screen (framed) of the PAP screen (see page 21), select **Left picture** if you want to listen to the left screen or select **Right picture** if you want to listen to the right screen.

 * The "BBE High Definition Sound system" is manufactured by Sony Corporation under license from BBE Sound, Inc. It is covered by U.S. Patent No. 4,638,258 and No. 4,482,866. The word "BBE" and BBE Symbol are trademarks of BBE Sound, Inc.

** This TV has been designed to create surround sound effect by simulating the sound of four speakers with two speakers, when the broadcast audio signal is Dolby Surround encoded. The sound effect can also be improved by connecting a suitable external amplifier (for details refer to page 25).

** Manufactured under license from Dolby Laboratories. "Dolby" and the double-D symbol  are trademarks of Dolby Laboratories.

The Features Menu

1 The "Features" menu allows you to alter various settings of the TV.

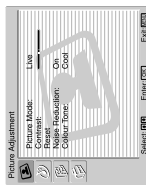

To do this:

Press the **MENU** button and press **▼** twice to select **Picture**, then press **OK** to enter this menu. Next press **▼** or **▲** to select the desired option and press **OK**. Finally read below how to operate into each option.

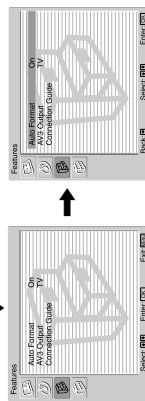

AUTO FORMAT

This option allows you to automatically change the aspect ratio of the screen.

To do this:

After selecting the option, press **OK**. Then press **▼** or **▲** to select **On** (if you wish the TV set to automatically switch the screen format according to the broadcast signal) or **Off** (if you wish to keep your preference). Finally press **OK** to store.

1 Even if you have selected "On" or "Off", you can always modify the format of the screen by pressing **#** repeatedly on the remote control to select one of the following formats:

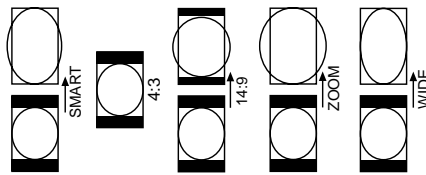

SMART: Initiation of wide screen effect for 4:3 broadcast.

4/3: Conventional 4:3 picture size, full picture information.

14/9: Compromise between 4:3 and 16:9 picture size.

ZOOM: Widescreen format for letterbox movies.

WIDE: For 16:9 broadcast. Full picture information.

1 In "SMART", "ZOOM" and "14/9" modes, parts of the top and bottom of the screen are cut off. Press **▼** or **▲** to adjust the position of the image on the screen (e.g. to read subtitles).

• Only "WIDE" and "4/3" modes can be selected for an RGB signal connected to the PC connector.

• According to the format of diffusion, black bands can always appear whatever the selected mode.

AV3 OUTPUT

This option allows you to select the source to be output from the Scart connector **3** so that you can record from this Scart any signal coming from the TV or from an external equipment connected to the Scart connector **1**, **2** or front connectors **4** and **4**.

1 If your VCR supports SmartLink, this procedure is not necessary.

To do this:

Once you have entered into the "Features" menu as it is explained in the previous page and after selecting the option, press **OK**. Then press **▼** or **▲** to select the desired output signal:

TV to output the aerial source.

AV1 to output sources connected to **1**.

AV2 to output sources connected to **2**.

AV4 to output sources connected to **4** and **4**.

AUTO to output the signal that is being viewed on the TV.

1 If you select "AUTO", the output signal will always be the same one that is displayed on the screen.

- If you have connected a decoder to the Scart **3** or to a VCR connected to this Scart, please remember to change back the "AV3 Output" to "TV" for correct unscrambling.

CONNECTION GUIDE

Once you have already connected the external equipment to the TV set, it is important for you to follow the instructions of this menu. If you proceed in this way, you will get the optimum picture settings related with the optional equipment.

To do this:

1 Once you have entered the "Features" menu as it is explained in the previous page and after selecting the option, press **OK**. Next press **▼** or **▲** to choose the equipment you want to connect among the available: **SAT** (satellit), **Decoder**, **DVD**, **GAME**, **VIDEO** or **DVD rec.** (DVD recorder). Next press **▼** to select the equipment chosen (equipment selected also can be deleted by pressing **▲**). Once you have selected all the equipment to be connected, press **▼** or **▲** to select "Confirm" and press **OK**.

2 A new menu will appear showing you on which Scart connector of the rear of the TV should be connected each equipment. Please connect each equipment according to this information to get the optimum picture setting of the optional equipment.

3 Once you have connected the optional equipment, press **▼** or **▲** to select "OK" and finally press the **OK** button of the remote control.

*We strongly recommend you to follow our connection proposals, but in case you do not agree press **▲** or **▼** to select «No» and next press the **OK** button. A new menu appears on the screen in which you can assign the connections according to your preferences.*

RGB CENTRING

1 This option is only available if an RGB source has been connected to the TV.

This option allows you to readjust the horizontal position of the picture in case you need to do it when connecting an RGB source.

To do this:

Once you have entered the "Features" menu as it is explained in the previous page and while watching an RGB source select the "RGB Centring" option and press **OK**. Then press **▼** or **▲** to adjust the centre of the picture between -5 and +5. Finally press **OK** to confirm and store.

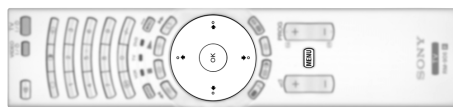
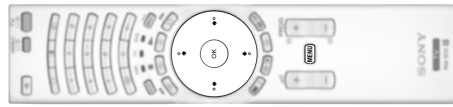

The Set Up Menu

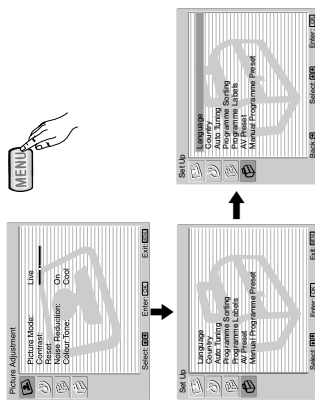

i The "Set Up" menu allows you to alter various options on this TV.

To do this:

Press the **MENU** button and press **↵** three times to select **☰**, then press **OK** to enter this menu. Next press **↵** or **⬅** to select the desired option and press **OK**. Finally read below how to operate into each option.

LANGUAGE

This option allows you to select the language that menus are displayed in.

To do this:

After selecting the option, press **OK** and then proceed in the same way as in step 2 of the section "Switching On the TV and Automatically Tuning" on page 10.

COUNTRY

This option allows you to select the country in which you wish to operate the TV set.

To do this:

After selecting the option, press **OK** and then proceed in the same way as in step 3 of the section "Switching On the TV and Automatically Tuning" on page 10.

AUTO TUNING

This option allows you to automatically search for and store all available TV channels.

To do this:

After selecting the option, press **OK** and then proceed in the same way as in the steps 5 and 6 of the section "Switching On the TV and Automatically Tuning" on page 11.

PROGRAMME SORTING

This option allows you to change the order in which the channels (TV Broadcast) appear on the screen.

To do this:

After selecting the option, press **OK** and then proceed in the same way as in the step 7 of the section "Switching On the TV and Automatically Tuning" on page 11.

continued...

PROGRAMME LABELS

This option allows you to name a channel using up to five characters (letters or numbers).

To do this:

- Once you have entered the "Set Up" menu as it is explained in the previous page and after selecting the option, press **OK**, then press **↵** or **⬅** to select the programme number with the channel you wish to name. Next press **OK**.
- With the first element of the Label column highlighted, press **OK** and **↵**, **⬅**, **➡**, or **↵** to select the letter; next press **OK**. When you have finished, press **↵**, **⬅**, or **➡** to select the word "End" on the screen and finally press **OK** to turn off the menu from the screen.

- i** To correct the letter, select "☰" on the screen to go back and press **OK**.
- For a blank, select "□" on the screen and press **OK**.

AV PRESET

This option allows you to:

- Designate a name to the external equipment you have connected to the input sockets of the TV set.

To do this:

- Once you have entered the "Set Up" menu as it is explained in the previous page and after selecting the option, press **OK**, then press **↵** or **⬅** to select the input source you wish to name: **AV1**, **AV2** or **AV3** for the rear Scarts, **AV4** for front connectors and **AV5** for the PC input connector. Next press **OK** twice.
- A label automatically appears in the label column:
 - If you want to use one of the predefined labels, press **↵** or **⬅** to select the desired label and finally press **OK**.

i The total predefined labels are: **VIDEO**, **DVD**, **CABLE**, **GAME**, **CAM** (camcorder), **SAT** (satellite) or **PC** (only for the AV5).

- If you want to set a different label, select **Edit** and press **OK**. Then, with the first element highlighted, press **↵**, **⬅**, **➡** or **↵** to select the letter, next press **OK**. When you have finished, press **↵**, **⬅**, **➡** or **↵** to select the word "End" on the screen and finally press **OK** to turn off the menu from the screen.

- i** To correct the letter, select "☰" on the screen to go back and press **OK**.
- For a blank, select "□" on the screen and press **OK**.

- Change the input sound level of the optional equipment connected.

To do this:

Once you have entered the "Set Up" menu as it is explained in the previous page and after selecting the option press **OK**, then press **↵** or **⬅** to select the input source you want to alter the input sound level: **AV1**, **AV2** or **AV3** for the rear Scarts, **AV4** for front connectors and **AV5** for the PC input connector. Next press twice **↵** to highlight the **Sound Offset** column. Finally press **OK** and **↵** or **⬅** to alter the input sound level between -9 and +9.

continued...



PAP (PICTURE AND PICTURE)

1 PAP divides the screen into two to watch two pictures in format 4:3 simultaneously.

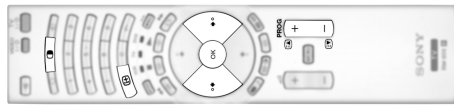

Switching PAP on and off

- 1 Press **OK** to display PAP.
 - 1** One of the screens will be framed to indicate that this is the active screen. It means that when you want to select the PAP source, you will be doing it in the active screen.
- 2 Press **OK** again to remove PAP.
 - 1** On the screen appears a banner guiding you how to operate PAP. This banner will disappear after some seconds but it always can be displayed again by pressing the **OK** button.

Changing the active screen

- 1** This is only possible if Media Selector is set to TV. To change the active screen (framed), press the **←** or **→** buttons.

Selecting PAP source

- 1 **Selecting a TV channel:**
 - Press the **←** button to select the left screen as the active screen. Next press the number buttons or **PROG +/-** to select a TV channel.
 - 1** Video input signals can not be displayed on the left screen.
- 2 **Selecting an input source:**
 - Press the **→** button to select the right screen as the active screen. Next press repeatedly the **←** button to watch the input signal of a connected equipment onto the TV right screen. For more details on which input symbol you want to choose, please see section "Viewing pictures from equipment connected to the TV" on page 25.
 - 1** RF signal (TV broadcast channels) can not be displayed on the right screen.

Selecting the sound

The sound of the active screen (framed) always comes from the TV set loudspeakers. Besides that, you can listen to the active screen as well as the non active screen via headphones.

To do this:
With the PAP switched on, refer to the section "The Sound Adjustment Menu", select "Headphones Set Up" and set the option "C PAP Sound" according your preference. For details see page 15.

1 In PAP (picture and picture) mode, the output from the Scart **2** is fixed to the right picture.

MANUAL PROGRAMME PRESET

This option allows you to:

- a) Preset channels or the VCR channel one by one to the programme order of your choice.

To do this:

 - 1 Once you have entered the "Set Up" menu as it is explained on page 18 and after selecting the "Manual Programme Preset" option, press **OK**. Next with **Programme** option highlighted press **OK**. Press **→** or **←** to select which programme number you want to preset the channel on (for VCR, select programme number "0"). Then press **←**.
 - 2 **1** The following option is only available depending on the country you have selected in the "Country" menu. After selecting the **System** option, press **OK**. Then press **→** or **←** to select the TV Broadcast system (**B/G** for western European countries, **D/K** for eastern European countries, **L** for France or **I** for United Kingdom). Then press **←**.
 - 3 After selecting the **Channel Number** option, press **OK**. Next press **→** or **←** to select the channel tuning ("C" for terrestrial channels or "S" for cable channels). Then press the number buttons to enter directly the channel number of the TV Broadcast or the channel of the VCR signal. If you do not know the channel number, press **→**, **←**, **→** or **←** to search for it. When you have tuned the desired channel, press **OK** twice to store.

Repeat all the above steps to tune and store more channels.
- b) Label a channel using up to five characters.

To do this:
Once you have entered the "Set Up" menu as it is explained on page 18 and after selecting the "Manual Programme Preset" option, press **OK**. Next with the **Programme** option, highlighted press the **PROG +/-** button to select the programme number with the channel you wish to name. When the programme you want to name appears on the screen, select the **Label** option and press **OK**. Then, with the first element highlighted, press **→**, **←**, **→** or **←** to select the letter, next press **OK**. When you have finished, press **→**, **←**, **→** or **←** to select the word "End" on the screen and finally press **OK** to turn off the menu from the screen.
- 1** To correct the letter, select "**□**" on the screen to go back and press **OK**.
• For a blank, select "**□**" on the screen and press **OK**.
- c) Fine tune the broadcast reception. Normally the automatic fine tuning (AFT) will give the best possible picture, however you can manually fine tune the TV to obtain a better picture reception in case the picture is distorted.

To do this:
While watching the channel (TV Broadcast) you wish to fine tune, and once you have entered the "Set Up" menu as it is explained on page 18 and after selecting the "Manual Programme" option, press **OK**. Then select the **AFT** option and press **→**. Next press **→** or **←** to adjust the fine tuning between -15 and +15. Finally press **OK** twice to store.
- d) Skip any unwanted programme numbers when they are selected with the **PROG +/-** buttons.

To do this:
Once you have entered the "Set Up" menu as it is explained on page 18 and after selecting the "Manual Programme Preset" option, press **OK**. Next with the **Programme** option highlighted, press the **PROG +/-** button to select the programme number you want to skip. When the programme you want to skip appears on the screen, select the **Skip** option and press **→**. Next press **→** or **←** to select **On**. Finally press **OK** twice to confirm and store.

To cancel this function afterwards, select "Off" instead of "On" in the step above.
- e) View and record scrambled channels (e.g. from a pay TV decoder) when using a decoder connected to Scart **3** directly or through a VCR.

1 This option is only available depending on the country you have selected in the "Country" menu.

To do this:
Once you have entered the "Set Up" menu as it is explained on page 18 and after selecting the "Manual Programme Preset" option, press **OK**. Next select the **Decoder** option and press **→**. Next press **→** or **←** to select **On**. Finally press **OK** twice to confirm and store.

To cancel this function afterwards, select "Off" instead of "On" in the step above.

Teletext

1 Teletext is an information service transmitted by most TV stations. The index page of the teletext service (usually page 100) gives you information on how to use the service. To operate teletext, use the remote control buttons as indicated below.

2 Teletext errors may occur if you use a channel (TV Broadcast) with a weak signal.



To switch on Teletext :

- 1 Select the broadcast channel which carries the teletext service you wish to view.
- 2 Press the **1** button one time to enter Picture and Text (P&T) mode. The screen is divided into two with the Text display on the left and the TV channel in the right corner.
- 3 If you wish to view the Text in full screen mode, press the **2** button a second time.



To select a Teletext page:

- Input 3 digits for the page number, using the numbered buttons.
- If you make a mistake, retype the correct page number.
 - If the counter on the screen continues searching, it is because the page is not available. If this is the case, input another page number.

To access the next or preceding page:

Press PROG + (**3**) or PROG - (**4**).

To freeze a teletext page:

Press **5**. Press it again to cancel the freeze.

To select a sub page:

A teletext page may consist of several sub pages. In this case, one or more arrows appear next to the page number and an information box is displayed at the bottom of the screen showing the number of sub pages contained on this page. As soon as sub pages are available, they start to automatically run. If you want to stop the show and select your desired sub page, press repeatedly **6** or **7**.

To Switch Off Teletext:

Press **0**.

Fastext

1 Fastext service lets you access Teletext pages with one button push. When you are in Teletext mode and Fastext is broadcast, a colour coded menu appears at the bottom of the teletext page. Press the appropriate coloured button (red, green, yellow or blue) to access the page corresponding to your menu choice.

NexTVview*

*(depending on availability of service).

1 NexTVview is an on-screen electronic programme guide, providing you with programme information for different broadcasters.

When looking for information you can search by theme (sports, art, etc...) or date.

2 If wrong characters appear when viewing NexTVview, use the menu system to enter the "Language" menu (see page 18) and select the same language as the NexTVview is broadcasted.

Displaying NexTVView

- 1 Select a broadcast channel providing a NexTVview service. In this case the indication "NexTVview" is displayed as soon as data is available.
- 2 To see NexTVview service you have two different types of NexTVview interface. These depend on the % of available data:
 - a) "Programme List" interface:
 - Whilst you are watching TV, and after the indication "NexTVview" (coloured white) is displayed on the screen, press the **1** button on the remote control to watch the "Programme List" interface (see fig. 1).
 - b) "Overview" interface:
 - Whilst you are watching TV, and after more than 50% of NexTVview data is available (100% data may not be available depending on the area) the indication "NexTVview" (coloured black) is displayed on the screen. Press the **2** button on the remote control to watch the "Overview" interface (see fig. 2).
- 3 To navigate through NexTVview:
 - Press **4** or **5** to move left or right.
 - Press **6** or **7** to move downwards or upwards.
 - Press **0** to confirm a selection.
 - If you have selected a programme, press **0** to get more information on the selected programme.
- 4 To switch NexTVview off, press the **1** button on the remote control.



"Programme List" interface (fig. 1):

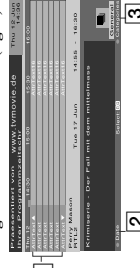

"Overview" interface (fig. 2):



1 Programme list

2 **Date:** Press the **red** button of the remote control to display the date screen, you can select the desired date by pressing **4** or **5**. Next press **0** to confirm.

3 Categories:

Press the **blue** button of the remote to display the icons (see below the Icon's key) for different themes. Next press **4** or **5** to select the desired icon and finally press the **0** button to confirm.

Icons' key:

- General:** All the programme information is listed by time and broadcast channels order.
- News**
- Movie**
- Sports**
- Show**
- Children**
- Arts**
- Music**

Connecting Equipment to the TV

- Using the following instructions you can connect a wide range of optional equipment to your TV set.
- Connecting cables are not supplied.

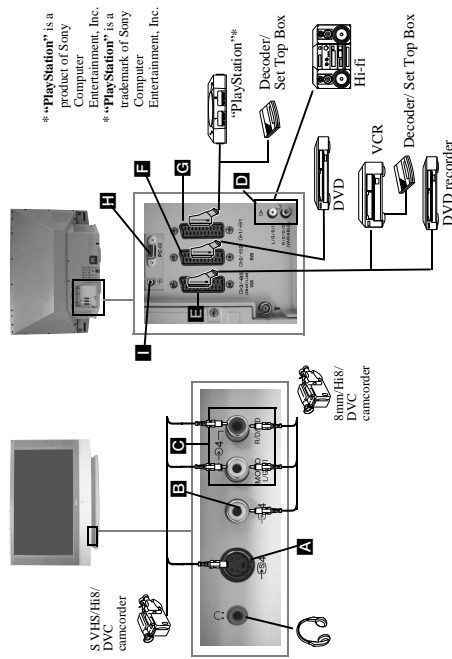

- To avoid picture distortion, do not connect external equipment to connectors **A** and **B** at the same time.
- Do not connect a Decoder to the Scart **F**.

Connecting a VCR

To connect a VCR, please refer to the section "Connecting the aerial and VCR" of this instruction manual on page 9.

Connecting a VCR that supports SmartLink

SmartLink is a direct link between the TV set and the VCR. For more information on SmartLink, please refer to the instruction manual of your VCR. If you use a VCR that supports SmartLink, please connect the VCR to the TV using a Scart lead to the Scart **C-3/↔3 E**.

If you have connected a decoder or a Set Top Box to the Scart **C-3/↔3 E** or through a VCR connected to this Scart

Select the "Manual Programme Preset" option in the "Set Up" menu and after entering in the "Decoder**" option, select "On" (refer to page 20). Repeat this option for each scrambled signal.

**This option is only available depending on the country you have selected in the "Country" menu.

continued...

Connecting Audio Equipment to the TV

Connect your audio equipment to the audio output sockets **D** if you wish to amplify the audio output from TV. Next, using the menu system, select the "Sound Adjustment" menu and set the "TV Speakers" to "One time off" or "Permanent off" (see page 15).

- The volume of the external speakers can be altered by pressing the volume buttons on the remote control. The Treble and Bass settings can also be altered through the "Sound Adjustment" menu (see page 14).

To enjoy "Dolby Virtual" sound effect through your audio equipment

Place the speakers of your equipment in front of your listening position and beside the TV set, keeping a distance of 50 cm between each speaker and the TV set. Then by using the menu system, select the menu "Sound Adjustment". Next select "Dolby Virtual" on the "Sound Effect" option (see page 14).

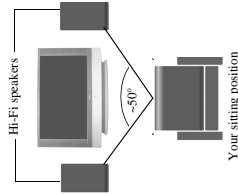

Viewing pictures from equipment connected to the TV



- 1 Connect your equipment to the designated TV socket, as indicated in the previous page.
- 2 Switch on the connected equipment.
- 3 To watch the picture of the connected equipment, press the **↔** button repeatedly until the correct input symbol appears on the screen.

Symbol

- **↔1** Audio / video input signal through the Scart connector **G**.
- **↔1** RGB input signal through the Scart connector **G**. This symbol appears only if an RGB source has been connected.

Input Signals

- **↔2** Audio / video input signal through the Scart connector **F**.
- **↔2** RGB input signal through the Scart connector **F**. This symbol appears only if an RGB source has been connected.
- **↔3** Audio/video input signal through the Scart connector **E**.
- **↔3** S Video Input signal through the Scart connector **E**. This symbol appears only if an S Video source has been connected.
- **↔4** Video input signal through the phono socket **B** and Audio input signal through **C**.
- **↔4** S Video Input through the front S Video input jack **A** and Audio signal through **C**. This symbol appears only if an S Video source has been connected.
- **↔5** RGB input signal through the PC connector **H** and **I**.

- 4 Press the **○** button on the remote control to return to the normal TV picture.

For Mono Equipment

Connect the phono plug to the L/G/S/I socket on the front of the TV and select **↔4** or **↔4** input signal using the instructions above. Next, refer to the "Sound Adjustment" section of this manual and set "Dual Sound" option to "A" on the sound menu screen (see page 14).

Remote Control Configuration for VCR or DVD

1 In its default condition this remote control will operate the basic functions of this Sony TV, Sony DVDs and most Sony VCRs. To control VCRs and DVDs of other manufacturers (and some Sony VCR models), the remote control needs to be configured.

fig. 3



- To do this:**
- Before you start, look up the 3 digit code for your brand of DVD or VCR from the list below. On those brands that have more than one code, enter the first code number.
 - A small label is added inside the battery door to allow you to record your brand codes.
- 1** Press the **Media Selector button** until the required green light (VCR or DVD) is lit (see fig. 1).
 - fig. 1: VCR TV DVD
 - 2** Before the green light goes out, press and hold the **yellow button** for approximately 6 seconds until the green light (VCR or DVD) starts flashing (see fig. 2).
 - 3** While the VCR and DVD lights are flashing, enter all three digits of the code for your brand of VCR or DVD (see the list below) using the **number buttons** on the remote control (see fig. 3).
 - fig. 2: VCR TV DVD
 - 4** If your selected code is entered correctly, the three green lights will be lit momentarily. Otherwise repeat all the above steps.
 - If your device is not working or some of the functions do not work please check that you entered the correct code set or try the next code listed against the brand.
 - Not all brands are covered and not all models of every brand may be covered.
 - 5** Turn on your VCR or DVD and check that the main functions work.
 - If your device is not working or some of the functions do not work please check that you entered the correct code set or try the next code listed against the brand.
 - Not all brands are covered and not all models of every brand may be covered.
- Always remember to press **Media Selector button** until the green light illuminates according to the equipment you want to operate with this remote control: **VCR, TV or DVD.**

Optimum Viewing Area

1 For the best picture quality, try to position the TV set so that you can view the screen from within the areas shown below.

Horizontal viewing area

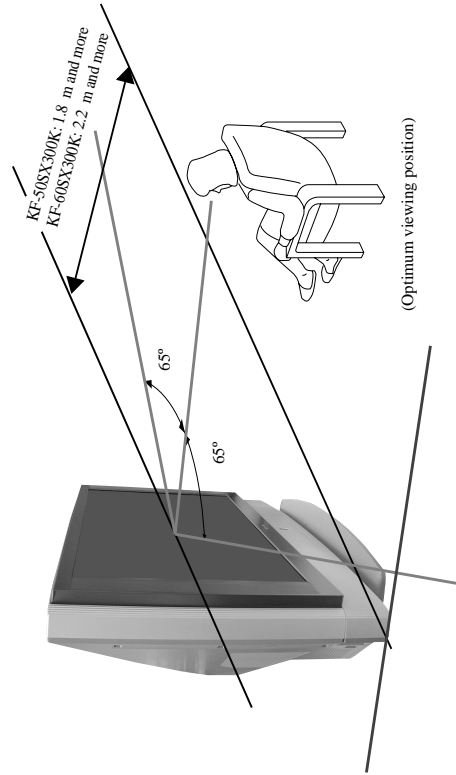

Vertical viewing area

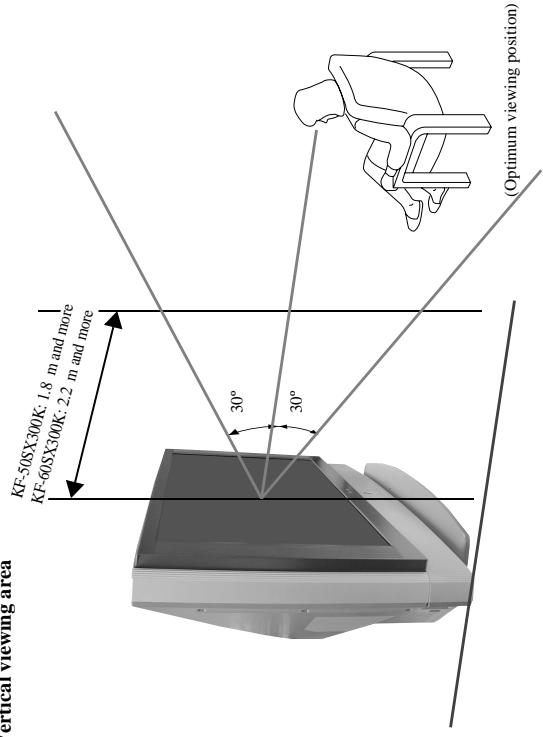

VCR Brand List		DVD Brand List	
Brand	Code	Brand	Code
SONY (VHS)	301, 302, 303, 308, 309, 362	SONY	001, 029, 030, 036, 037, 038, 039, 040, 041, 042, 043, 044, 053, 054, 055
SONY (BETA)	303, 307, 310	AIWA	021
SONY (DV)	304, 305, 306	AKAI	032
AIWA	325, 331, 351	DENON	018, 027, 020, 002
AKAI	326, 329, 330	GRUNDIG	099, 028, 023, 024, 016, 003
DAEWOO	342, 343	HITACHI	025, 026, 015, 004, 035
GRUNDIG	358, 355, 360, 361, 320, 351, 366	JVC	006, 017
HITACHI	327, 333, 334	KENWOOD	008
JVC	314, 315, 322, 344, 352, 353, 354, 348, 349	LG	015, 014, 034
LG	352, 338	LOEWE	009, 028, 023, 024, 016, 003
LOEWE	358, 355, 360, 361, 320, 351	MATSUI	013, 016
MATSUI	356, 357	ORION	022, 033
ORION	328	PANASONIC	018, 027, 020, 002, 045, 046, 047
PANASONIC	321, 323	PHILIPS	009, 028, 023, 024, 016, 003, 031
PHILIPS	311, 312, 313, 316, 317, 318, 358, 359, 363, 364	PIONEER	044, 050, 051, 052
SAMSUNG	339, 340, 341, 345	SAMSUNG	011, 014
SANYO	335, 336	SANYO	007
SHARP	324	SHARP	019, 027
THOMSON	319, 350, 365	THOMSON	012
TOSHIBA	357	TOSHIBA	003, 048, 049
		YAMAHA	018, 027, 020, 002

Replacing the lamp

 When the lamp becomes dark or the picture colour is not normal or the lamp indicator  on the TV set flashes, replace with a new lamp.

- Only use the lamp XL-2100E for replacement. If you use another lamp, it may cause damage to the TV set.
- Do not remove the lamp except when replacing it.
- Before replacing the lamp, turn off the power and disconnect the power cord.
- Replace the lamp only after it becomes cool. The front glass of the lamp remains at least 100 °C (212 °F) even after the power has been turned off for 30 minutes.
- Do not place the old lamp in proximity to children or flammable material.
- Do not get the old lamp wet, or insert objects inside the lamp. It may cause the lamp to explode.
- Do not place the old lamp near easily flammable objects, as this may cause fire. Also, do not put your hand inside the lamp compartment, as you may be burned.
- Attach the new lamp securely. If it is not securely attached, the picture may become dark.
- Do not touch or stain the front glass of the new lamp or the glass of the lamp compartment. If the glass become dirty, the picture quality may deteriorate or the lamp life may shorten.
- Attach the lamp cover firmly. If it is not firmly attached, the power will not turn on.
- When the lamp burns out, a noise is audible. This does not indicate damage to the TV set.
- Consult your nearest Sony service center to obtain a new lamp.
- Always remember to dispose of used lamps in an environmentally friendly way.

- 1 **Turn off the power and disconnect the power cord.**
 - If you start changing the lamp without disconnecting the power cord, the standby indicator  on the TV set flashes. Disconnect the power cord to continue changing the lamp.
 - Replace the lamp 30 minutes or more after the power is turned off to allow it to cool.
 - Prepare the new lamp.

- 2 **Loosen the two screws placed on the left and right corner of the rear of the TV with an object such as a coin.**



- 3 **Remove the front panel.**
Remove the front panel without moving the TV set

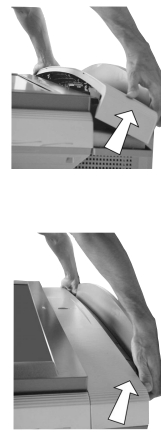

 Grasp the left and right side of the front panel with your fingers and pull it forward. Be careful not to catch your fingernails.

- 4 **Loosen the screw with an object such as a coin and remove the lamp cover.**

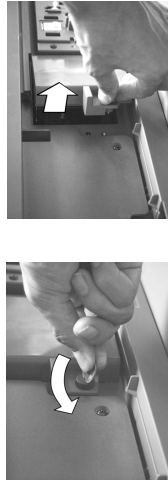

- 5 **Loosen the two screws and pull out the lamp.**

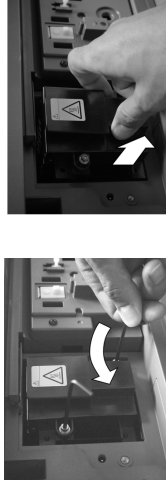

Loosen two screws with the hexagonal key supplied.

Pull out the lamp by the handle.

 The lamp is still extremely hot immediately after the power is turned off. Be careful that you don't touch the front glass or surrounding area of the lamp or the glass of the lamp compartment.

- 6 **Attach the new lamp.**
Replace the new lamp securely in the lamp receptacle and fasten the screws tightly using the hexagonal key supplied.

- 7 **Attach the lamp cover.**
Fasten the screw tightly with an object such as a coin.

- 8 **Attach the front panel.**
Attach the front panel by pushing left and right side into place. Next, fast again the two screws placed on the left and right corner of the rear of the TV.

Technical Specifications

TV system:

Depending on your country selection:

B/G/H, D/K, L, I

Colour system:

PAL
SECAM, NTSC 3.58, 4.43 (only Video In)

Channel Coverage:

VHF: E2-E12
UHF: E21-E69
CATV: S1-S20
HYPER: S21-S41
D/K: R1-R12, R21-R69
L: F2-F10, B-Q, F21-F69
I: UHF B21-B69



Panel System:

LCD (Liquid Crystal Display) panel.

Projected picture size:

- KF-50SX300K: 50 inches (approx. 127 cm measured diagonally).
- KF-60SX300K: 60 inches (approx. 153 cm measured diagonally).

Rear Terminals



- AV1  21-pin SCART connector (CENELEC standard) including audio/video input, RGB input, TV audio/video output.
- AV2  21-pin SCART connector (CENELEC standard) including audio / video input, RGB input, monitor audio/video output.

Channel Coverage:





VHF: E2-E12
UHF: E21-E69
CATV: S1-S20
HYPER: S21-S41
D/K: R1-R12, R21-R69
L: F2-F10, B-Q, F21-F69
I: UHF B21-B69

Panel System:

LCD (Liquid Crystal Display) panel.

- AV3  3-pin audio output (Left/Right) - phono jacks
- AV4  4-pin audio output - minijack.
- PC  PC input.

Front Terminals

- AV5  S video input - 4 pin DIN
- AV6  video input - phono jack
- AV7  audio input - phono jacks
- AV8  headphones jack

Sound Output:

2 x 20 W (music power)
2 x 10 W (RMS)
Woofer:
30 W (music power)
15 W (RMS)

Power Consumption:

210 W

Standby Power Consumption:

≤ 1 W

Dimensions (w x h x d) :

- KF-50SX300K: approx. 1376 x 923 x 442 mm.
- KF-60SX300K: approx. 1618 x 1062 x 542 mm.

Weight:

- KF-50SX300K: approx. 37.5 kg.
- KF-60SX300K: approx. 48.5 kg.

Accessories supplied:

- 1 Remote Control (RM-906)
- 2 Batteries (IEC designated, AAA size).
- 1 PC input cable.
- 1 Hexagon key.
- 2 Brackets.
- 2 Screws.
- 1 Cleaning Cloth.

Other features:

- Digital Comb Filter (High resolution).
- Teletext, Fastext, TOPtext.
- NexTVView.
- SmartLink.
- TV system autodetection.
- Dolby Virtual.
- BBG Digital.
- NICAM.
- PAP.
- ACI (Auto Channel Installation).
- Auto Format.

Optional accessories:

- Stand especially designed for these sets (SU-50/60SX3).

PC Input Specifications

PC Input Timing

Input signal frequency:

Horizontal: 31,4 - 48,4 KHz.

Vertical: 59 - 61 Hz.

Maximum Resolution: 1024 dots x 768 lines.

Preset mode timing table for PC

N°	Resolution (dots x lines)	Graphic mode	Horizontal frequency (kHz)	Vertical frequency (Hz)
1	640 x 480	VESA 60	31.469	59.940
2	800 x 600	VESA 60	37.879	60.317
3	1024 x 768	VESA 60	48.363	60.004

Design and specifications are subject to change without notice.

This instruction manual has been printed on:

Ecological Paper - Totally Chlorine Free 

Troubleshooting

 Here are some simple solutions to problems which may affect the picture and sound.

Problem	Solution
No picture (screen is dark) and no sound.	<ul style="list-style-type: none"> • Check the aerial connection. • Plug the TV in and press the ⏻ button on the front of the TV. • If the standby indicator ⓪ is on, press TV /⓪ button on the remote control.
Poor or no picture (screen is dark), but good sound.	<ul style="list-style-type: none"> • Using the menu system, select the "Picture Adjustment" menu and select "Reset" to return to the factory settings (see page 13).
No picture or no menu information from equipment connected to the Scart connector.	<ul style="list-style-type: none"> • Check that the optional equipment is on and press the ⏻ button repeatedly on the remote control until the correct input symbol is displayed on the screen (see page 25).
Good picture, no sound.	<ul style="list-style-type: none"> • Press the ↵ + button on the remote control. • Check that "TV Speakers" is "On" in the "Sound Adjustment" menu (see page 14). • Check that headphones are not connected.
No colour on colour programmes.	<ul style="list-style-type: none"> • Using the menu system, select the "Picture Adjustment" menu and select "Reset" to return to factory settings (see page 13).
When you switch on the TV the last channel you were watching before switching the TV off does not appear.	<ul style="list-style-type: none"> • This is not a malfunction. Press the number buttons on the remote control to select the desired channel.
Distorted picture when changing programmes or selecting teletext.	<ul style="list-style-type: none"> • Turn off any equipment connected to the Scart connector on the rear of the TV.
Wrong characters appear when viewing teletext.	<ul style="list-style-type: none"> • Use the menu system to enter the "Country" menu (see page 18) and select the country in which you operate the TV set. For Cyrillic languages, we recommend selecting Russia country if your own country does not appear in the list.
Wrong characters appear when viewing NextView.	<ul style="list-style-type: none"> • Use the menu system to enter the "Language" menu (see page 18) and select the same language that NextView is broadcast in.
Snowy picture when viewing a TV channel.	<ul style="list-style-type: none"> • Using the menu system, select the "Manual Programme Preset" menu and adjust Fine Tuning (AFT) to obtain better picture reception (see page 20). • Using the menu system, select the "Noise Reduction" option in the "Picture Adjustment" menu and select "On" to reduce the noise in the picture (see page 13).
No unscrambled picture whilst viewing an unscrambled channel with a decoder or a Set Top Box connected through the Scart connector ⓪ 3/ ⏻ 3	<ul style="list-style-type: none"> • Using the menu system, select the "Features" menu and set "AV3 Output" to "TV" (see page 17). • Check that the Decoder or the Set Top Box is not connected on the scart ⓪ 3/ ⏻ 3.

Problem	Solution
⏻ , ↵ , ⏻ and ⏻ buttons do not work in PAP mode.	<ul style="list-style-type: none"> • PAP navigation is only possible in TV mode, please check that Media Selector is set to TV.
Remote control does not function.	<ul style="list-style-type: none"> • Be sure you are pointing it towards the remote control receiver (see page 8). • Check that the Media Selector on the remote control is set to the device you are using (VCR, TV or DVD). • If the remote control does not operate the VCR or DVD even when the Media Selector has been set correctly. Enter the necessary code set as explained on page 26. • Replace the batteries. • Contact your nearest Sony service centre.
The standby indicator ⓪ on the TV flashes.	<ul style="list-style-type: none"> • Turn the TV off. Turn the TV on again, if the lamp indicator is still lit then replace the internal lamp. For details refer to pages 28 and 29.
The lamp indicator ⓪ on front of the TV set is lit.	

Personal Computer

Problem	Solution
If no picture is displayed and the NO SYNC message appears on the screen.	<ul style="list-style-type: none"> • Check that the video signal cable is properly connected and all plugs are firmly seated in their sockets. • Check that the 15-Sub video input connector's pins are not bent or pushed in.
Personal Computer output format	<ul style="list-style-type: none"> • Check that the output signal format of the Personal computer is set to the corresponding format for the television. In case it is not, adjust the resolution and refresh rate to the corresponding signal (refer to page 31).
Problems caused by the connected computer	<ul style="list-style-type: none"> • The computer is in power saving mode. Try pressing any key on the computer keyboard. • Check that the computer's power is "on". • Check that the computer's keyboard is properly connected. • Check that the graphic board is completely seated in the proper bus slot. • In case of a notebook PC, check that the monitor signal is set to the external output, and the signal is correctly output to the television.
Some picture lines are not correctly displayed.	<ul style="list-style-type: none"> • Using the menu system, select the "Picture Adjustment" menu and adjust the "Lines Correction" option between -20 and +20 (see page 13).
Blurred letters or vertical lines or shade or noise is visible in detailed patterns.	<ul style="list-style-type: none"> • Small letters, check or mesh patterns cannot be accurately displayed. In this case, increase the size of the fonts and/or reduce the mesh pattern brightness.
The Startup or the Setting screens of the Personal Computer cannot be displayed.	<ul style="list-style-type: none"> • Depending on the PC, the Startup or Setting screens may not be displayed due to the output format of the image. These screens can be displayed on the monitor of the Personal Computer.

 **• If you continue to experience problems, have your TV serviced by qualified personnel.**
• Never open the casing yourself.

SECTION 3 DISASSEMBLY

3-1. REAR COVER REMOVAL

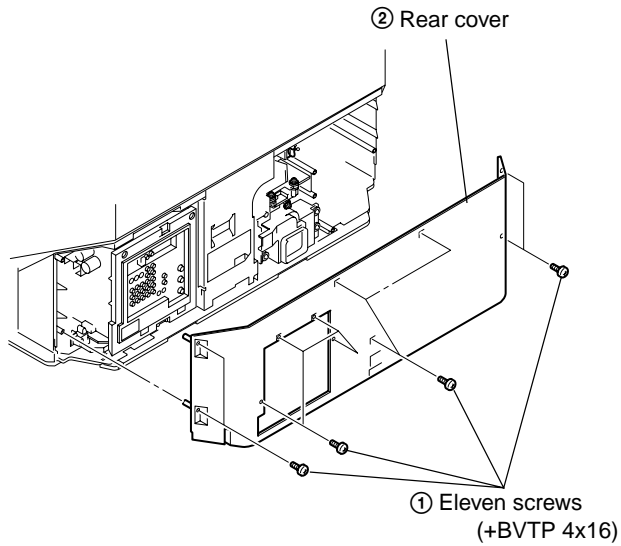

3-2. CENTER PILLAR REMOVAL

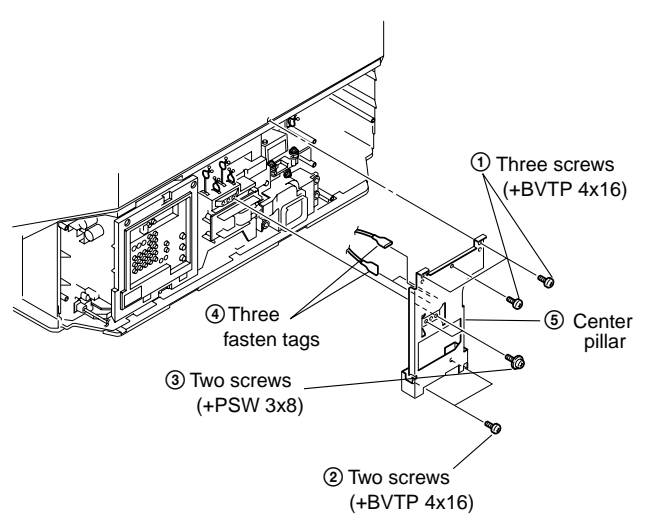

3-3. SERVICE POSITION

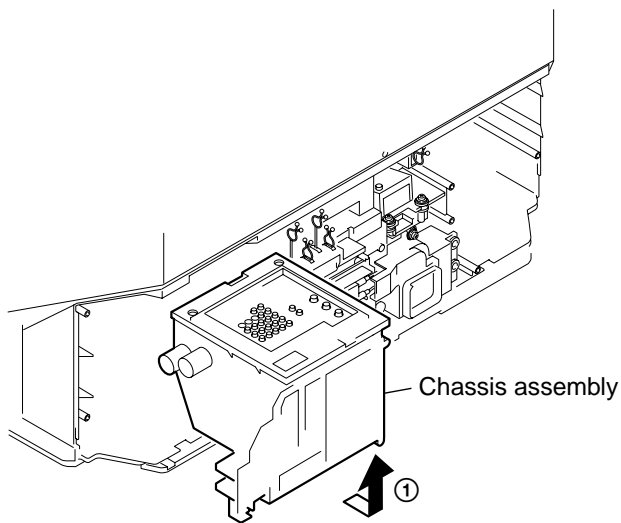

3-4. CHASSIS, OPTICAL UNIT, DC FAN REMOVAL

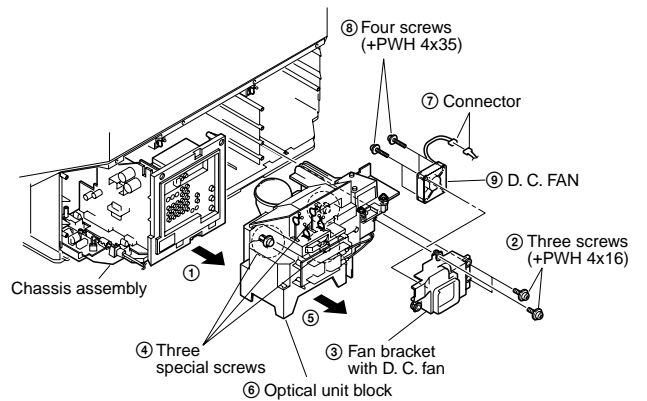

3-5. POWER BLOCK REMOVAL

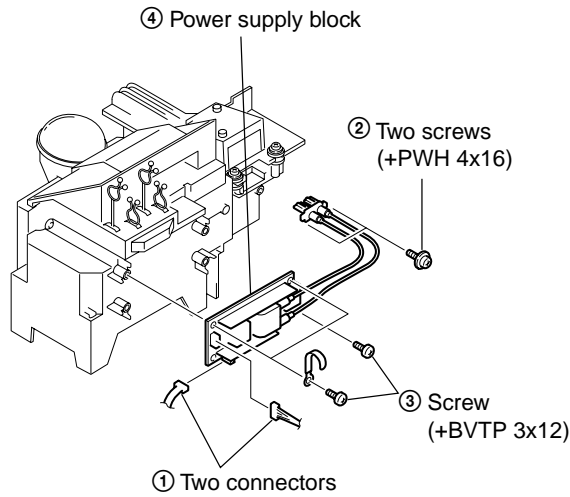

3-6. H1 BOARD REMOVAL

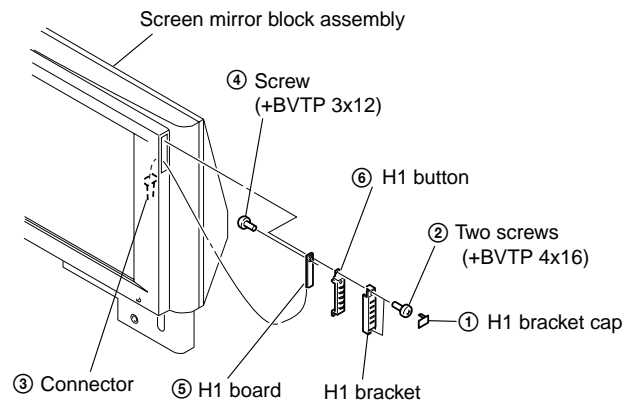

3-7. H2 BOARD REMOVAL

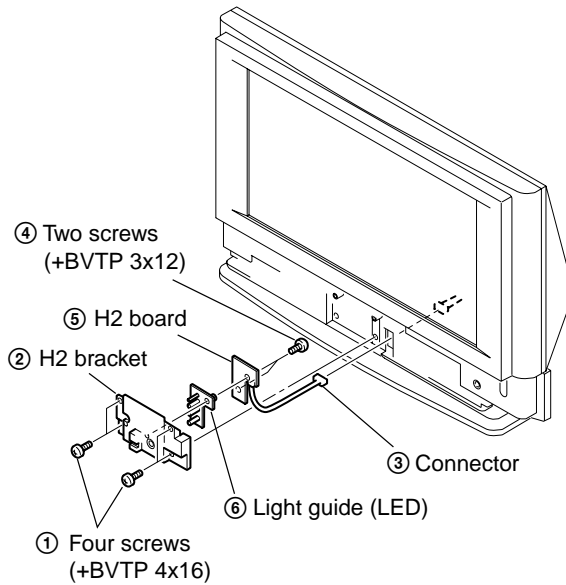

3-8. H3 BOARD REMOVAL

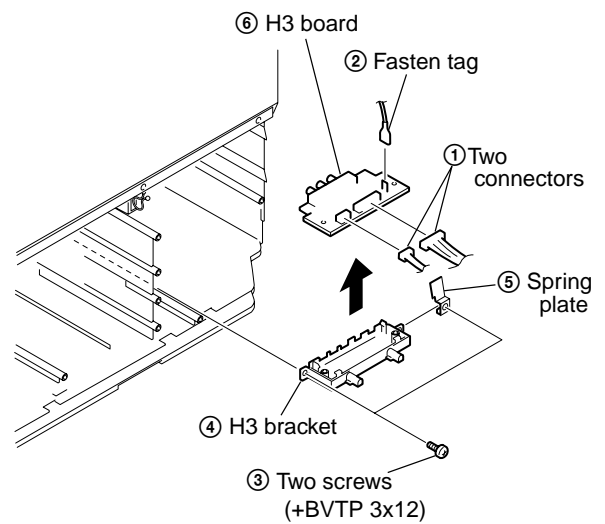

3-9. A BOARD REMOVAL

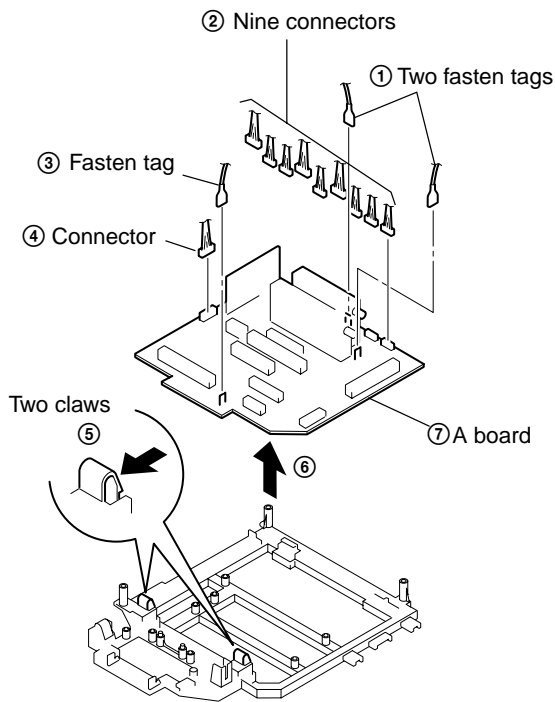

3-10. G BOARD REMOVAL

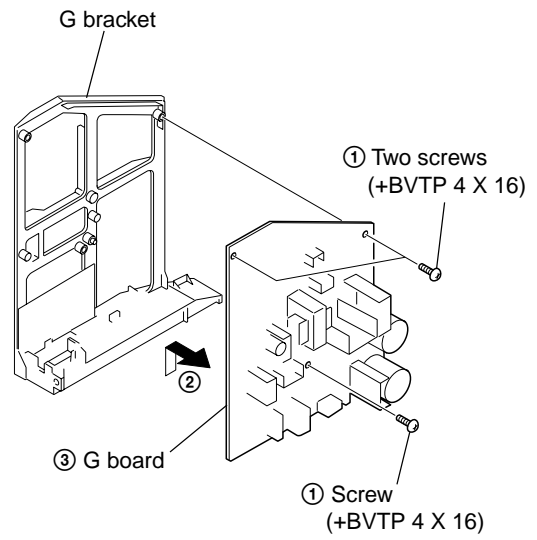

3-11. T BOARD REMOVAL

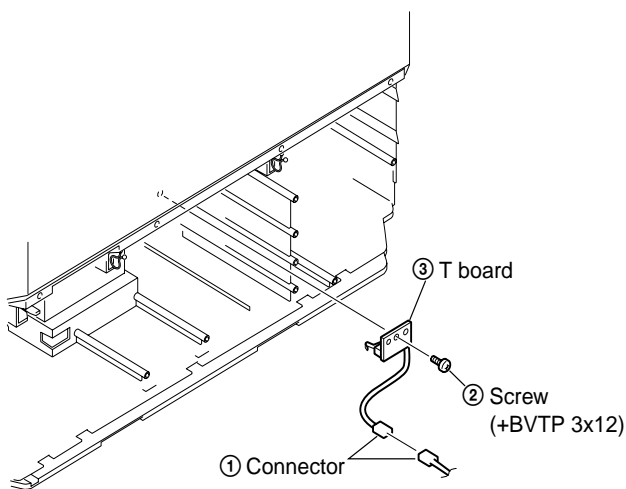

3-12. FRONT PANEL REMOVAL

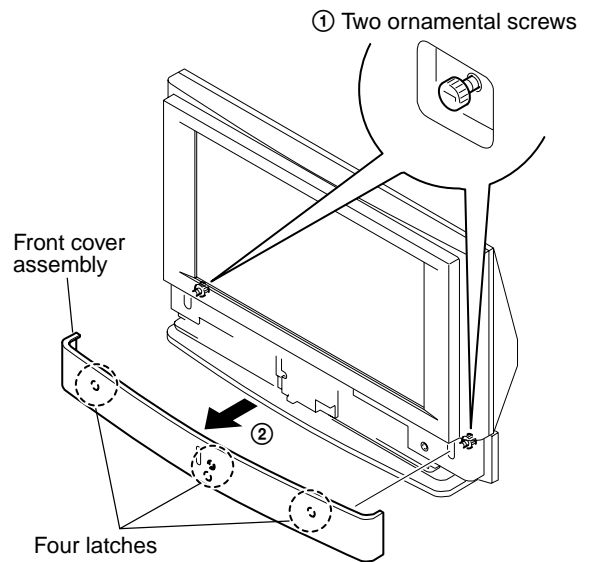

3-13. FRONT COVER REMOVAL

3-14. CONTROL PANEL REMOVAL

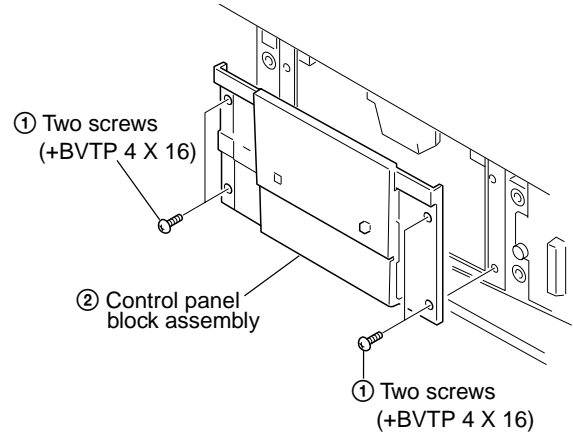
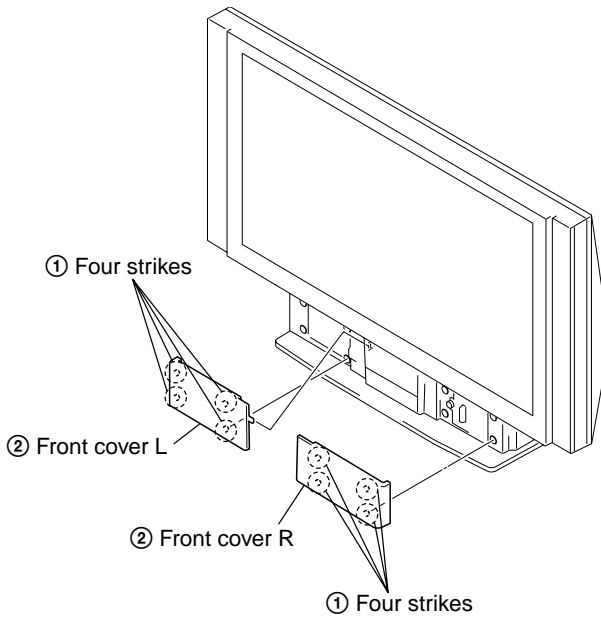

3-15. SCREEN, MIRROR BLOCK ASSEMBLY REMOVAL

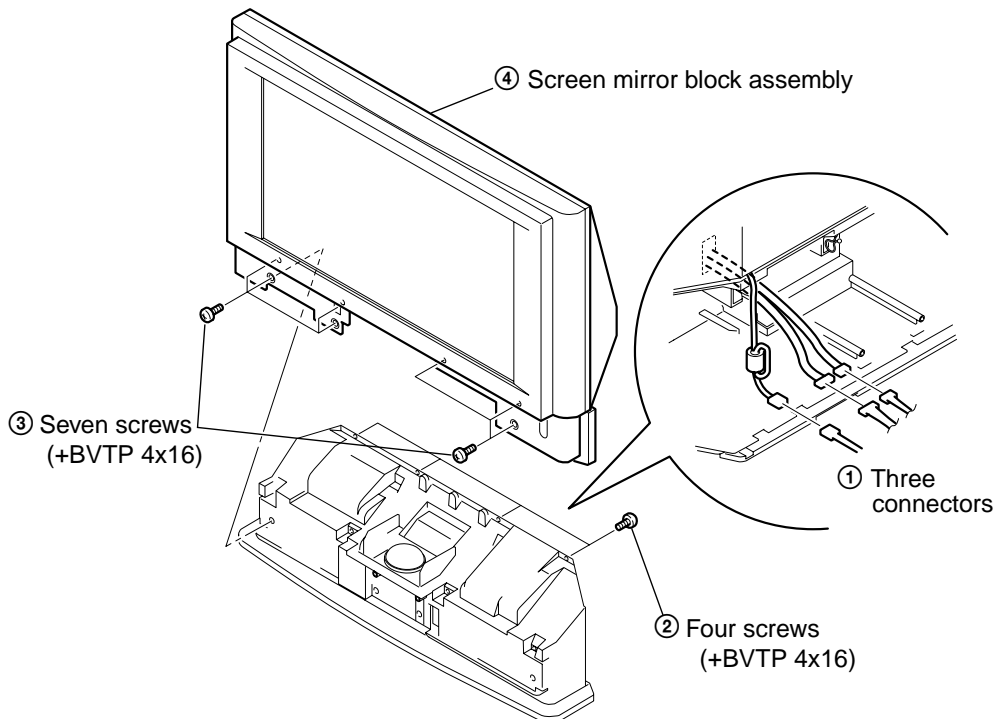

3-16. MIRROR COVER BLOCK ASSEMBLY REMOVAL

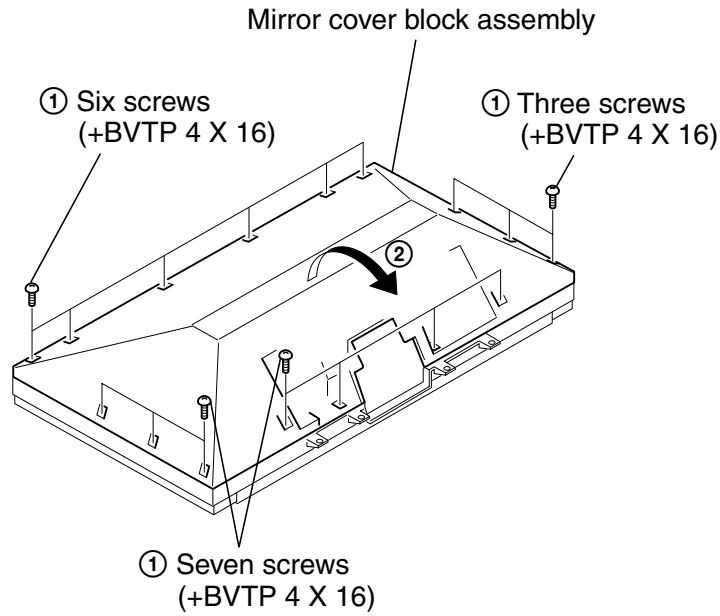

3-17. CONTRAST SCREEN, DIFFUSION PLATE REMOVAL

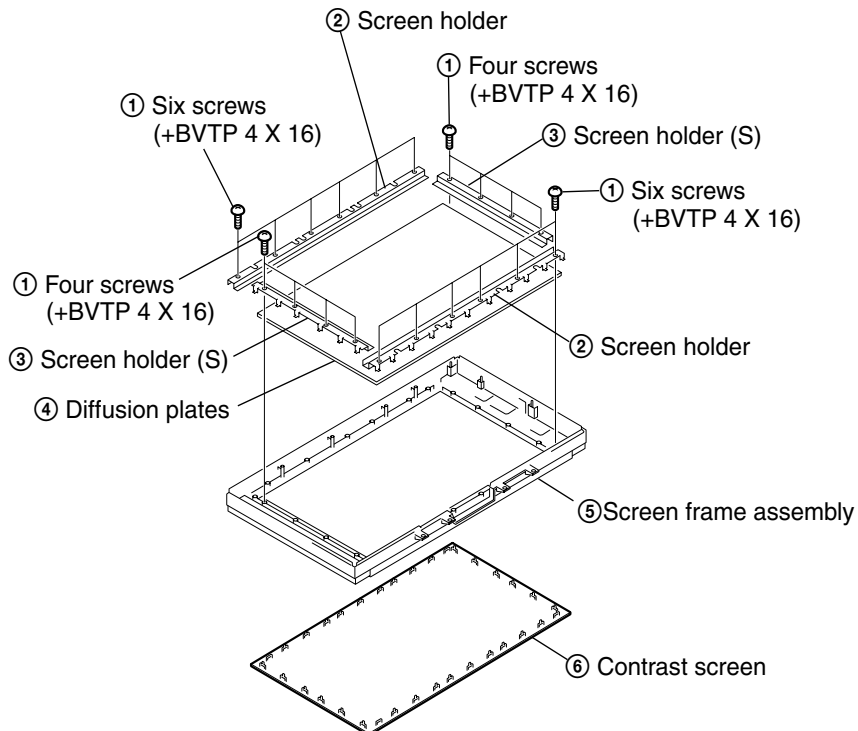

3-18. WOOFER BLOCK ASSEMBLY REMOVAL

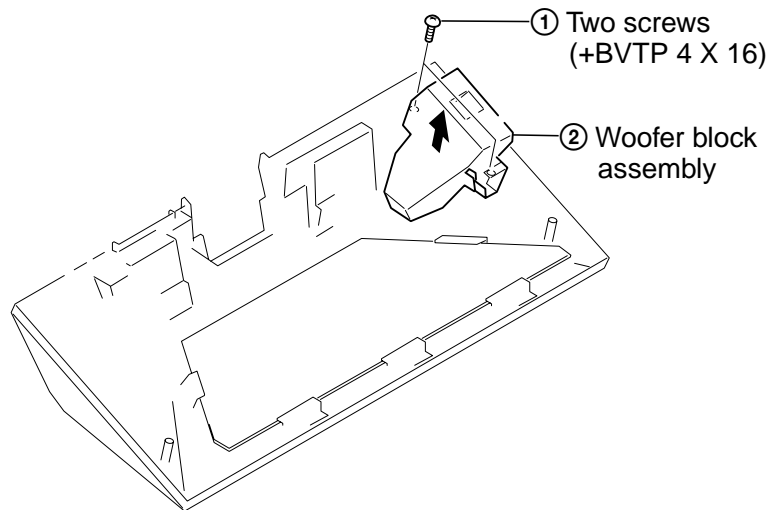

3-19. SPEAKER REMOVAL

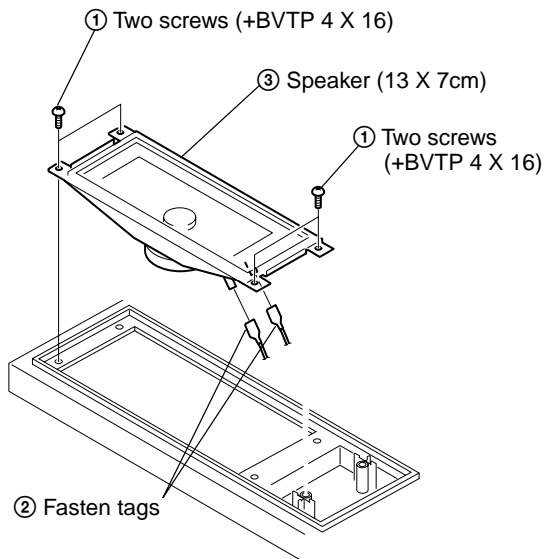

3-20. MIRROR REMOVAL

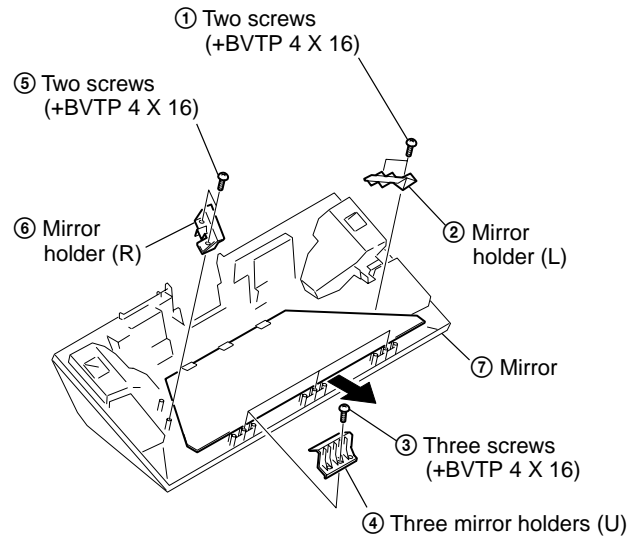

SECTION 4 ELECTRICAL ADJUSTMENTS

4-1. Adjustments with Commander

Service adjustments to this model can be performed using the supplied remote Commander RM-906.

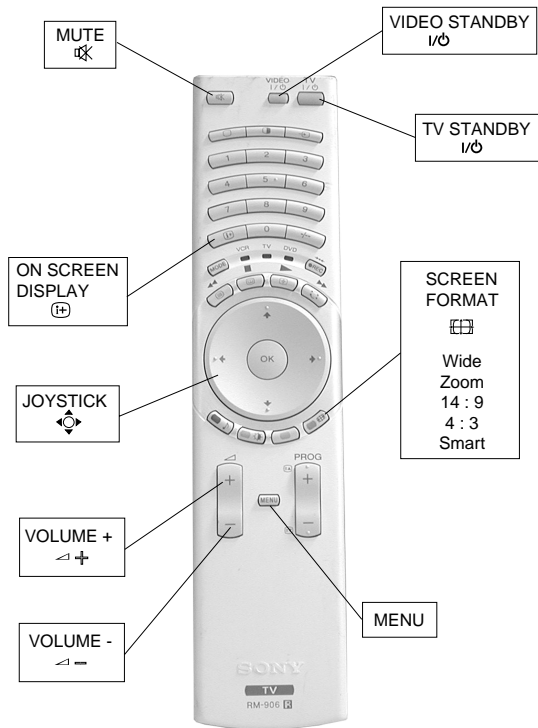

4-1-1. How to Select Each Mode

1. Selection of Mode Between PAL and NTSC

- PAL mode : Enter PAL signal.
- NTSC mode : Enter NTSC signal. (VIDEO input only)

2. Selection of Screen Format

1. Press ' [] (BLUE)' button on the commander to select a different screen format '14 : 9', '4 : 3' etc.

4-1-2. Programming the Remote Commander for Operation in Service Mode

1. Press the VCR/TV/DVD button until the TV LED lights.
2. Press and hold the yellow button for approx. 5 seconds until the TV LED flashes quickly.
3. Press 99999. All three LED's should light. The remote commander is now set to Service Mode.
4. To return the remote commander to normal operation mode repeat steps 1. and 2. then press 00000. All three LED's should light. The remote commander is now set to normal mode.



4-1-3. Setting the TV into Service Mode

1. Program the remote commander for operation in Service Mode as described above.
2. Turn on the TV main power switch.
3. Press the video standby button on the remote commander twice. 'TT _' will appear in the upper right corner of the screen. Other status information will also be displayed.
4. Press 'MENU' on the remote commander to obtain the following menu on the screen.

Service Main Menu:LE4 (v3.39)	NVM VERSION FFH
Service Design Error	▶
Select: ▲ ▼ Select Item: ▶	

5. Move to the corresponding adjustment item using the up or down arrow buttons on the Remote Commander.
6. Press the right arrow button to enter into the required menu item.
7. Press the 'Menu' button on the Remote Commander to quit the Service Mode when all adjustments have been completed.

Note :

- After carrying out the service adjustments, to prevent the customer accessing the 'Service Menu' switch the TV set OFF and then ON.

4-1-4. Screen Display for Service Menu

Service	
Display Picture Audio	▶
Select: ▲ ▼ Select Item: ▶ Previous Menu: ◀	

Display	
Display adjustment	▶
OSD adjustment	
Temperature control	
Select: ▲ ▼	Select Item: ▶ Previous Menu: ◀

Display adjustment			
Description	(min,max)	Default	Value
HORIZONTAL ADJ	(0,2047)	0	0 ▶
VERTICAL ADJ	(0,1023)	0	0
Select: ▲ ▼	Select Item: ▶	Previous Menu: ◀	

Picture	
Picture settings	▶
White balance	
Select: ▲ ▼	Select Item: ▶ Previous Menu: ◀

Picture settings			
Description	(min,max)	Default	Value
FLAT_POINT	(0,100)	70	35 ▶
PK_RATIO	(0,15)	0	0
SUB_COLOUR_PAL_NTSC	(0,63)	32	32
SUB_COLOUR_SECAM	(0,63)	32	32
BRIGHT_MAX	(0,255)	255	255
BRIGHT_MIN	(0,255)	10	10
CONTRAST_MAX	(0,255)	50	50
CONTRAST_MIN	(0,255)	0	0
Select: ▲ ▼	Select Item: ▶	Previous Menu: ◀	

Audio	
BBE OFF mode	▶
BBE Natural/V.Dolby offsets	
BBE Dynamic offsets	
BBE Cinema offsets	
Subwoofer level adjustments	
Audio detection thresholds	
Select: ▲ ▼	Select Item: ▶ Previous Menu: ◀

BBE OFF mode			
Description	(min,max)	Default	Value
SW_FREQ_OFF	(5,40)	20	20 ▶
BAND1_OFF_OFFSET	(-96,96)	0	0
BAND2_OFF_OFFSET	(-96,96)	0	0
BAND3_OFF_OFFSET	(-96,96)	0	0
BAND4_OFF_OFFSET	(-96,96)	0	0
BAND5_OFF_OFFSET	(-96,96)	0	0
BBE_LOUDNESS_OFF	(0,68)	0	0
Select: ▲ ▼	Select Item: ▶	Previous Menu: ◀	

White balance			
Description	(min,max)	Default	Value
R_GAIN	(0,255)	160	150 ▶
G_GAIN	(0,255)	160	136
B_GAIN	(0,255)	160	131
R_BIAS	(0,255)	80	92
G_BIAS	(0,255)	80	80
B_BIAS	(0,255)	80	83
R_WARM_GAIN_OFF	(-128,127)	0	0
G_WARM_GAIN_OFF	(-128,127)	0	0
B_WARM_GAIN_OFF	(-128,127)	0	0
R_WARM_BIAS_OFF	(-128,127)	0	0
G_WARM_BIAS_OFF	(-128,127)	0	0
B_WARM_BIAS_OFF	(-128,127)	0	0
R_COLD_GAIN_OFF	(-128,127)	0	0
G_COLD_GAIN_OFF	(-128,127)	0	0
B_COLD_GAIN_OFF	(-128,127)	0	0
R_COLD_BIAS_OFF	(-128,127)	0	0
G_COLD_BIAS_OFF	(-128,127)	0	0
B_COLD_BIAS_OFF	(-128,127)	0	0
R_SECAM_GAIN_OFF	(-128,127)	0	0
G_SECAM_GAIN_OFF	(-128,127)	0	0
B_SECAM_GAIN_OFF	(-128,127)	0	0
R_SECAM_BIAS_OFF	(-128,127)	0	0
G_SECAM_BIAS_OFF	(-128,127)	0	0
B_SECAM_BIAS_OFF	(-128,127)	0	0
Select: ▲ ▼	Select Item: ▶	Previous Menu: ◀	

Design	
CXA2149 - AVSwitch Device	▶
MSP3411 - Sound Processor Device	
TDA988x - IF Device	
TUA60xx - PLL Device	
VSP9427 - Video Processor Device	
CXA2019 - Chroma Decoder	
CXD3804 - 3D Comb Filter	
DPS9450A - Digital Processor and Scaler Device	
CXD9671GG - Digital Gamma Device	
CXA7001R - LCD Driver Device	
Select: ▲ ▼	Select Item: ▶ Previous Menu: ◀

Error monitor		
WORKING TIME:	(Hours:Minutes)	82:33
Error counters:		
E02: LAMP COV		45
E03: LAMP PROT		8
E04: FAN PROT		55
E05: TEMP PROT		0
E06: IIC		0
E07: NVM		0
E09: TUNER		2
E10: SOUND		0
E12: SCANRATE		4
E14: BACKEND		2
E17: AVSWITCH		10
E22: DIGITAL GAMMA		3
E23: LCD Drivers		6
E24: SPEAKER PROT		0
Select: ▲ ▼	Previous Menu: ◀	

4-1-5. Operation Method for Adjustments

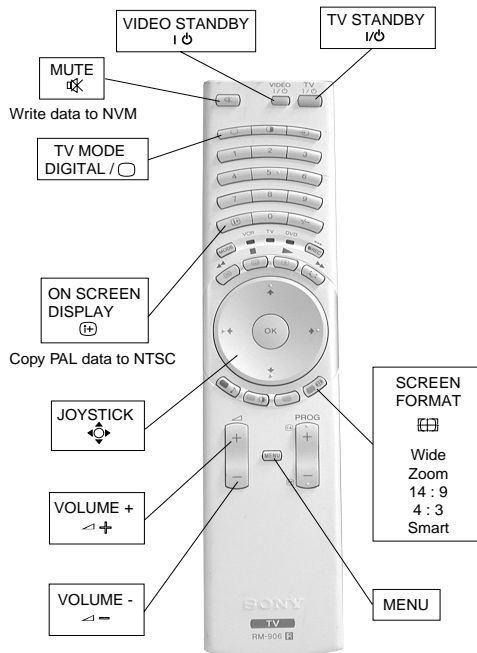

1. Functions of Keys on Commander

- **▲ ▼ ◀ ▶**: Changes data value. (up or down)
: Marker moves up, down, or to the left or right.
(in fine adjustment mode)
- **(OK)** : Switches marker moving method.
(in fine adjustment mode)
joystick (▲, ▼, ◀, ▶) keys → ① and ④ buttons

4-2. Screen Center Adjustment

1. Input a monoscope PAL signal in wide mode.
2. Go into the Service mode; Display adjustment.
3. For Horizontal adjustment; modify to centre left-right.
4. For Vertical adjustment; modify to centre up-down.
5. Display PC input with XGA 60Hz resolution.
6. Check picture is not hidden on the top.

4-3. TEST-TEST MODE

Is available by programming the Remote Commander for operation in Service Mode [As shown on Page 27] then pressing the VIDEO button twice, OSD 'TT' appears. The functions describe below are available by selecting the two numbers. To release 'Test Test Mode', press 00, or switch the TV into Stand-by mode.

00	'TT' mode off
01	Set picture level to maximum
02	Set picture level to minimum
03	Set Volume to 35%
04	Set Volume to 50%
05	Set Volume to 65%
06	Set Volume to 80%
07	Ageing mode on
08	Shipping Condition
11	Sub Picture adjustment
12	Sub Colour adjustment
13	Sub Brightness adjustment
15	Rotation coil test
16	Picture level 50%
19	Factory Mode Enable/Disable
21	Destination ADEKR
22	Destination BL
24	Destination U
31	Inches selection (50/60 inches)
32	Memory Stick enable flag
33	Hor-Ver LCD adjustment
34	RPJ selector flag
35	Wide model selection
36	VM off/on test
39	Direct access to auto tuning
42	Subwoofer test
43	Select Dual A sound
44	Select Dual B sound
45	Select Mono sound
46	Select Stereo sound
49	Set NVM as virgin
53	FM Overmodulation enable/disable
58	Memory Stick test
62	AM from baseband enable/disable
73	Enable Zweiton D/K2 system (6.5/6.74)
74	Enable Zweiton D/K3 system (6.5/6.74)
78	Balance full left
79	Balance full right
87	Local keys test
91	Set 14:9 zoom mode
93	Set 16:9 zoom mode
94	Set ZOOM zoom mode
95	Set 4:3 zoom mode
96	Set Smart zoom mode (for FX66)
99	Display Error and Working Time menu

MEMO

A series of horizontal dotted lines for writing a memo.

5-1. BLOCK DIAGRAMS (1)

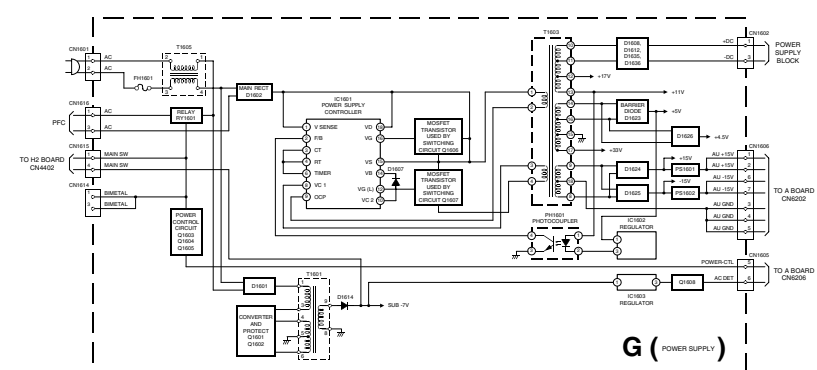
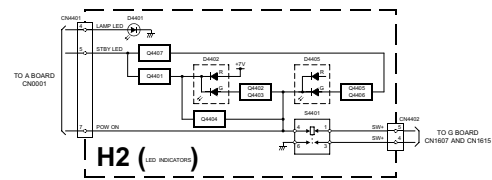
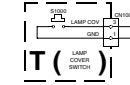
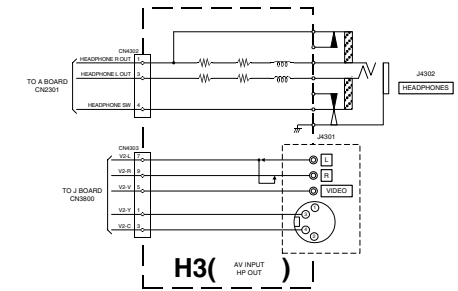
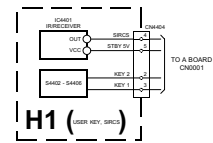
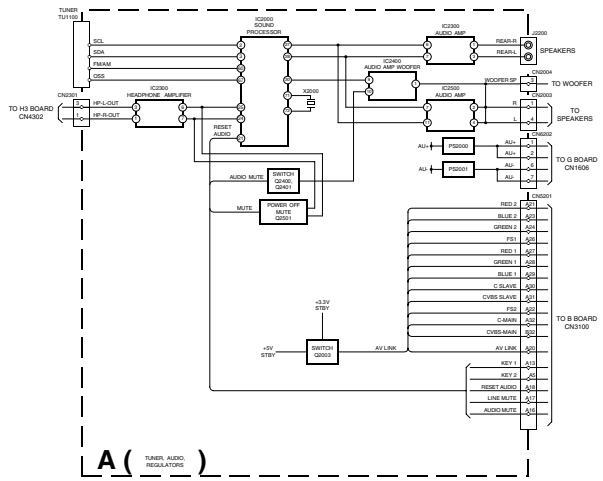

5-1. BLOCK DIAGRAMS (2)

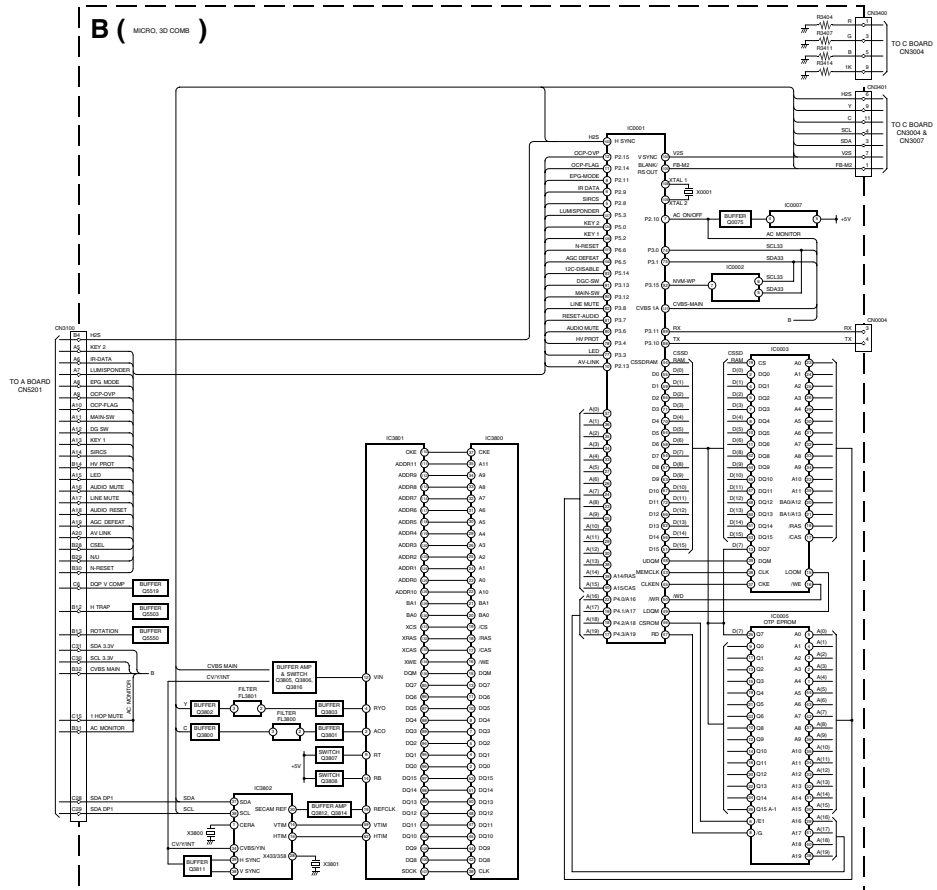

5-1. BLOCK DIAGRAMS (3)

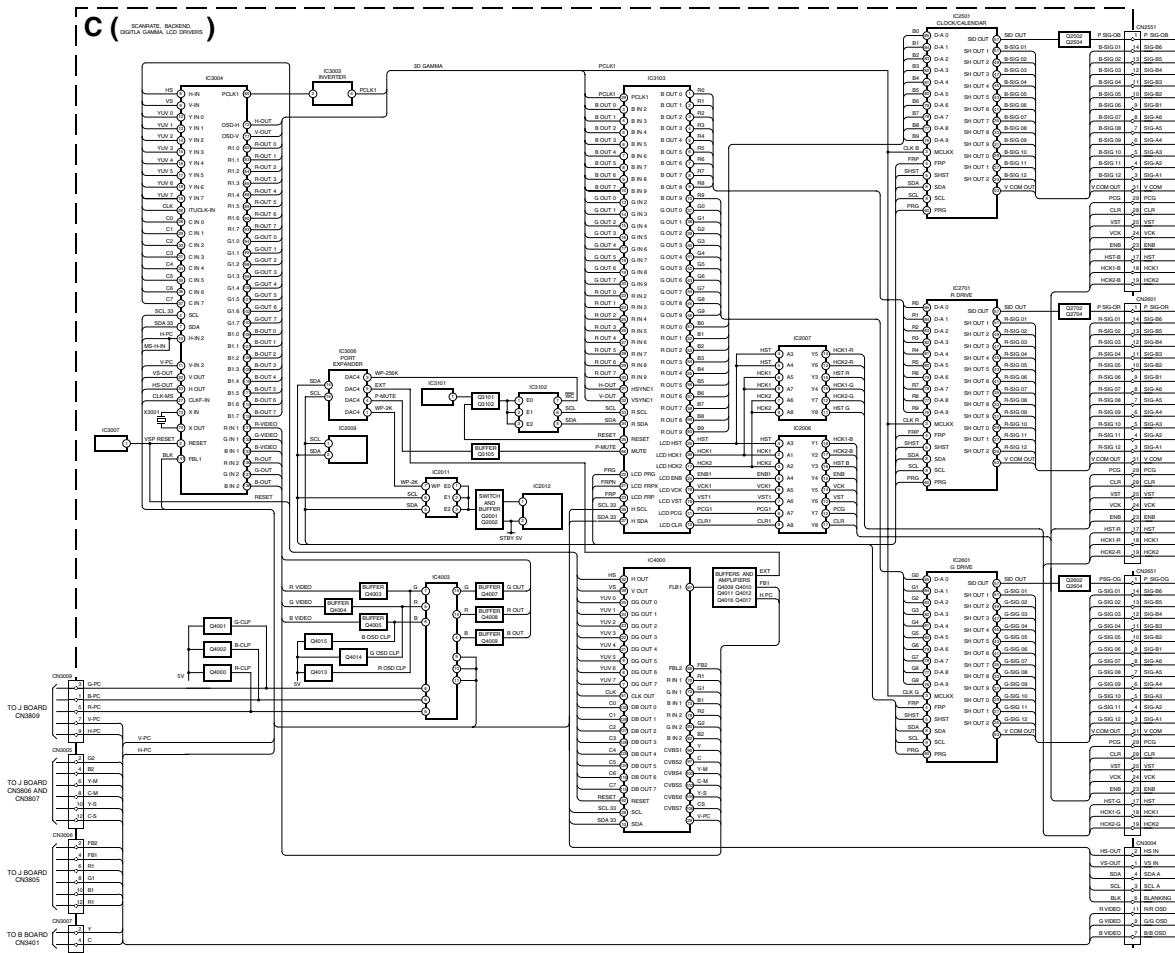

5-1. BLOCK DIAGRAMS (4)

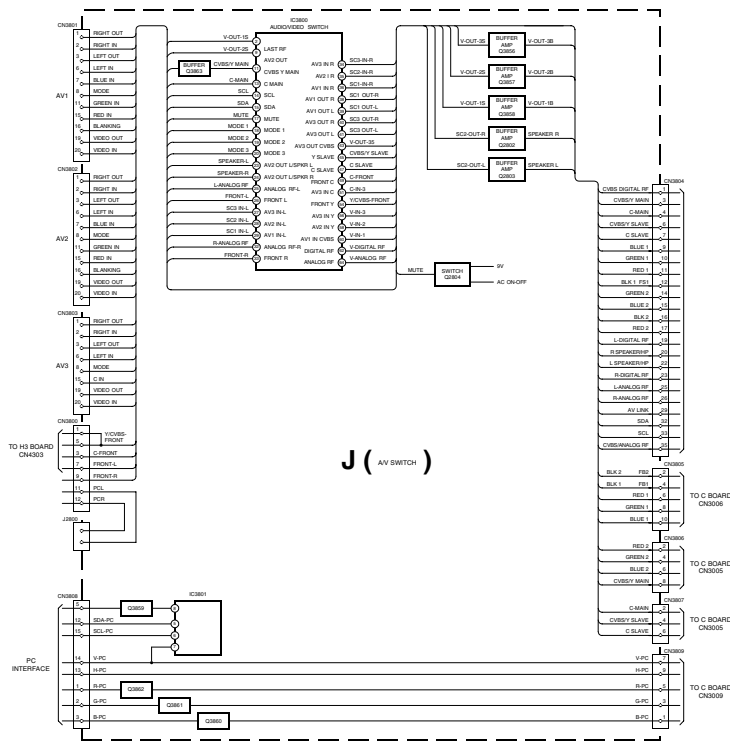

5-2. CIRCUIT BOARD LOCATION

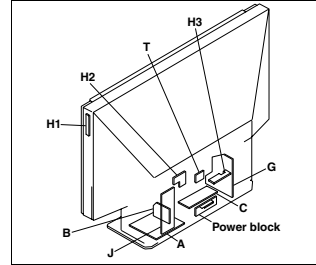

5-3. SCHEMATIC DIAGRAMS AND PRINTED WIRING BOARDS

- Note :**
- All capacitors are in μF unless otherwise noted.
 - μF : μF ; 50WV or less are not indicated except for electrolytic types.
 - Indication of resistance, which does not have one for rating electrical power, is as follows.
- Pitch : 5mm
Electrical power rating : 1/4W
- Chip resistors are 1/10W
 - All resistors are in ohms.
 - $k = 1000$ ohms, $M = 1000,000$ ohms
 - : nonflammable resistor.
 - : fusible resistor.
 - : internal component.
 - : panel designation or adjustment for repair.
 - All variable and adjustable resistors have characteristic curve B, unless otherwise noted.
 - All voltages are in Volts.
 - Readings are taken with a 10Mohm digital multimeter.
 - Readings are taken with a color bar input signal.
 - Voltage variations may be noted due to normal production tolerances.
 - : B + bus.
 - : B - bus.
 - : RF signal path.
 - : earth - ground.
 - : earth - chassis.

Reference Information

RESISTOR	RN	: METAL FILM
	RC	: SOLID
	FPRD	: NON FLAMMABLE CARBON
	FUSE	: NON FLAMMABLE FUSIBLE
	RS	: NON FLAMMABLE METAL OXIDE
	RB	: NON FLAMMABLE CEMENT
	RW	: NON FLAMMABLE WIREWOUND
		: ADJUSTMENT RESISTOR
COIL	LF-8L	: MICRO INDUCTOR
CAPACITOR	TA	: TANTALUM
	PS	: STYROL
	PP	: POLYPROPYLENE
	PT	: MYLAR
	MPS	: METALIZED POLYESTER
	MPP	: METALIZED POLYPROPYLENE
	ALB	: BIPOLAR
	ALT	: HIGH TEMPERATURE
	ALR	: HIGH RIPPLE

Note : The components identified by shading and marked Δ are critical for safety. Replace only with the part numbers specified in the parts list.

Note : Les composants identifiés par une trame et par une marque Δ sont d'une importance critique pour la sécurité. Ne les remplacer que par des pièces de numéro spécifié.

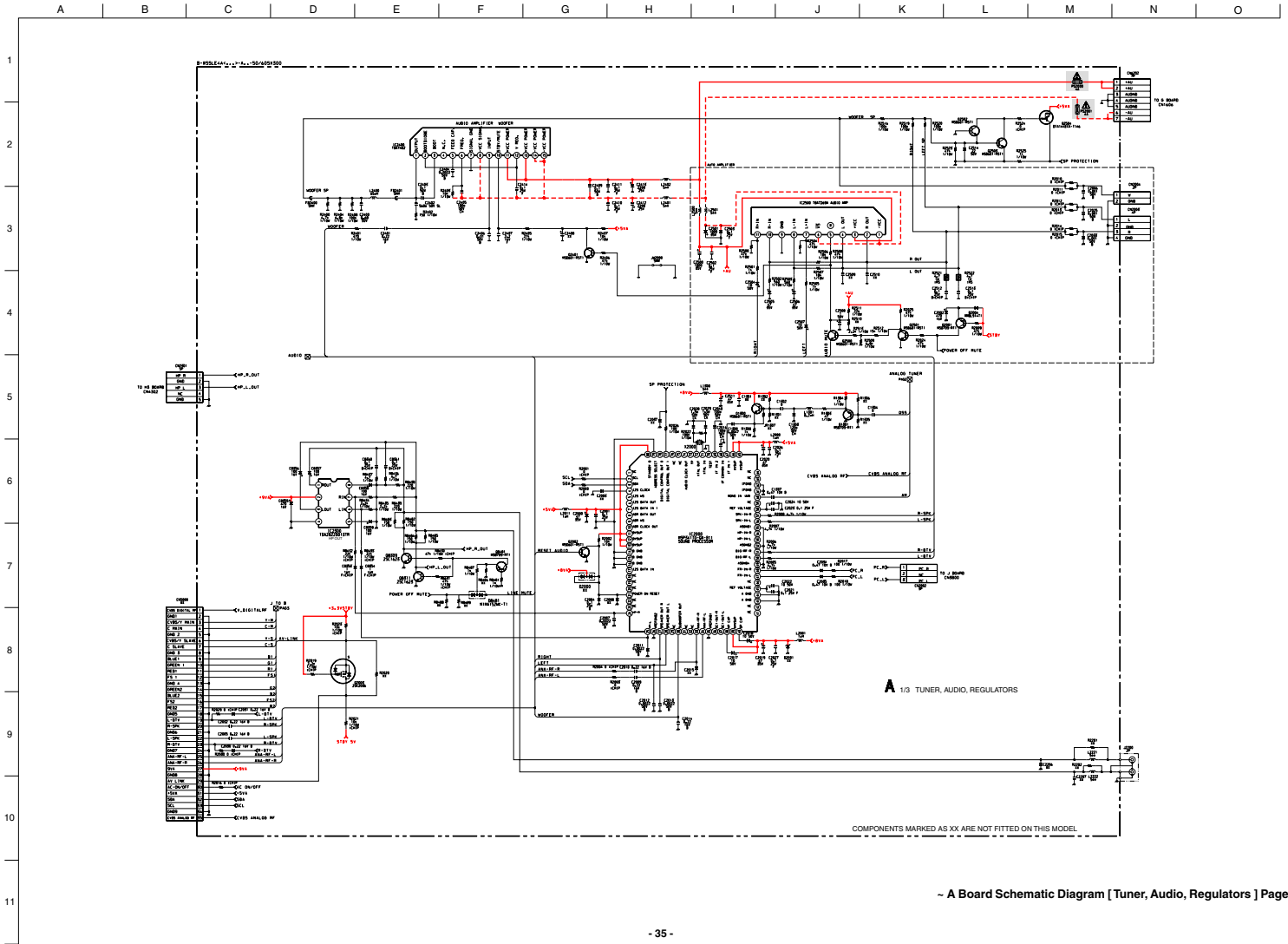

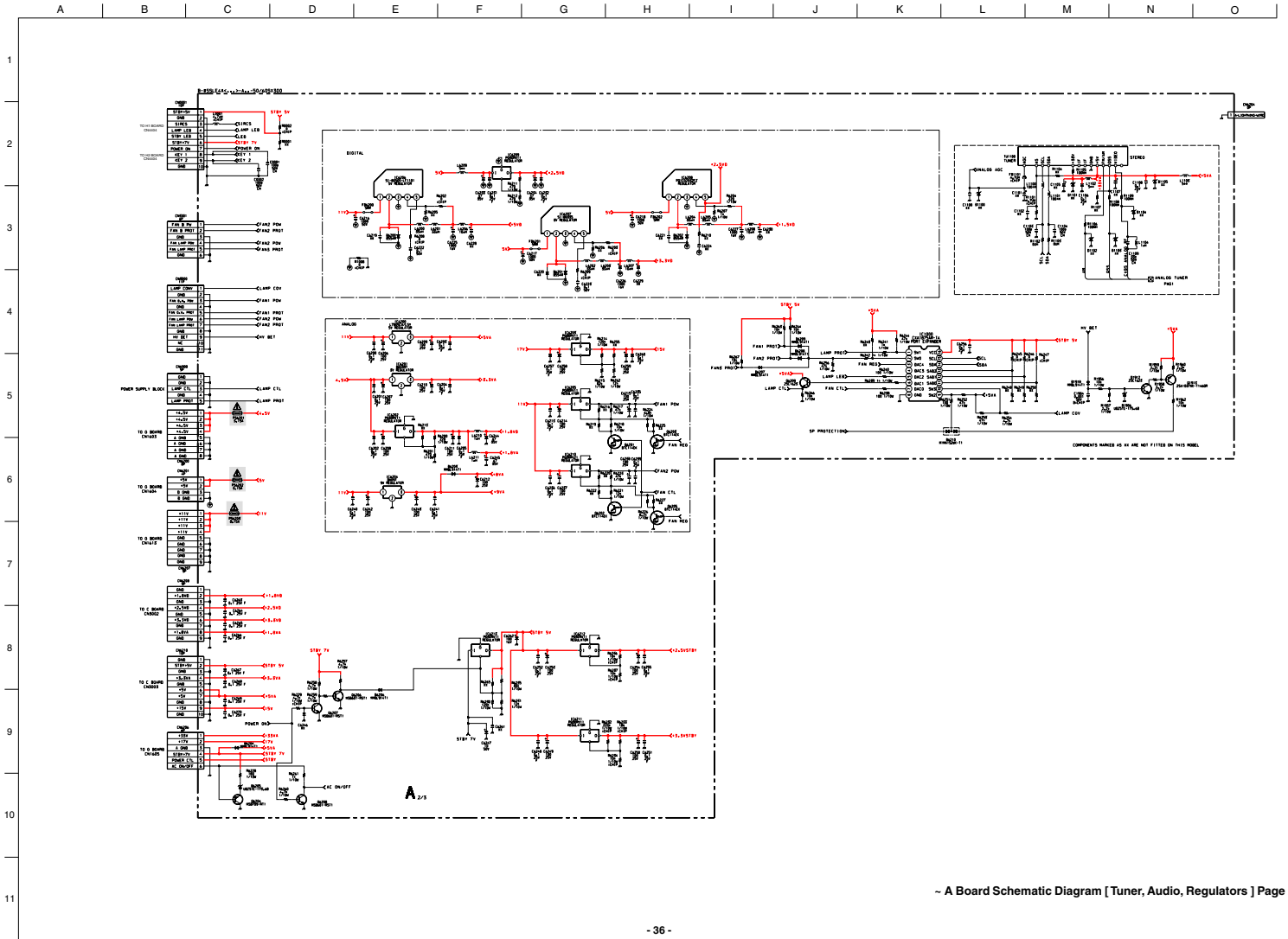

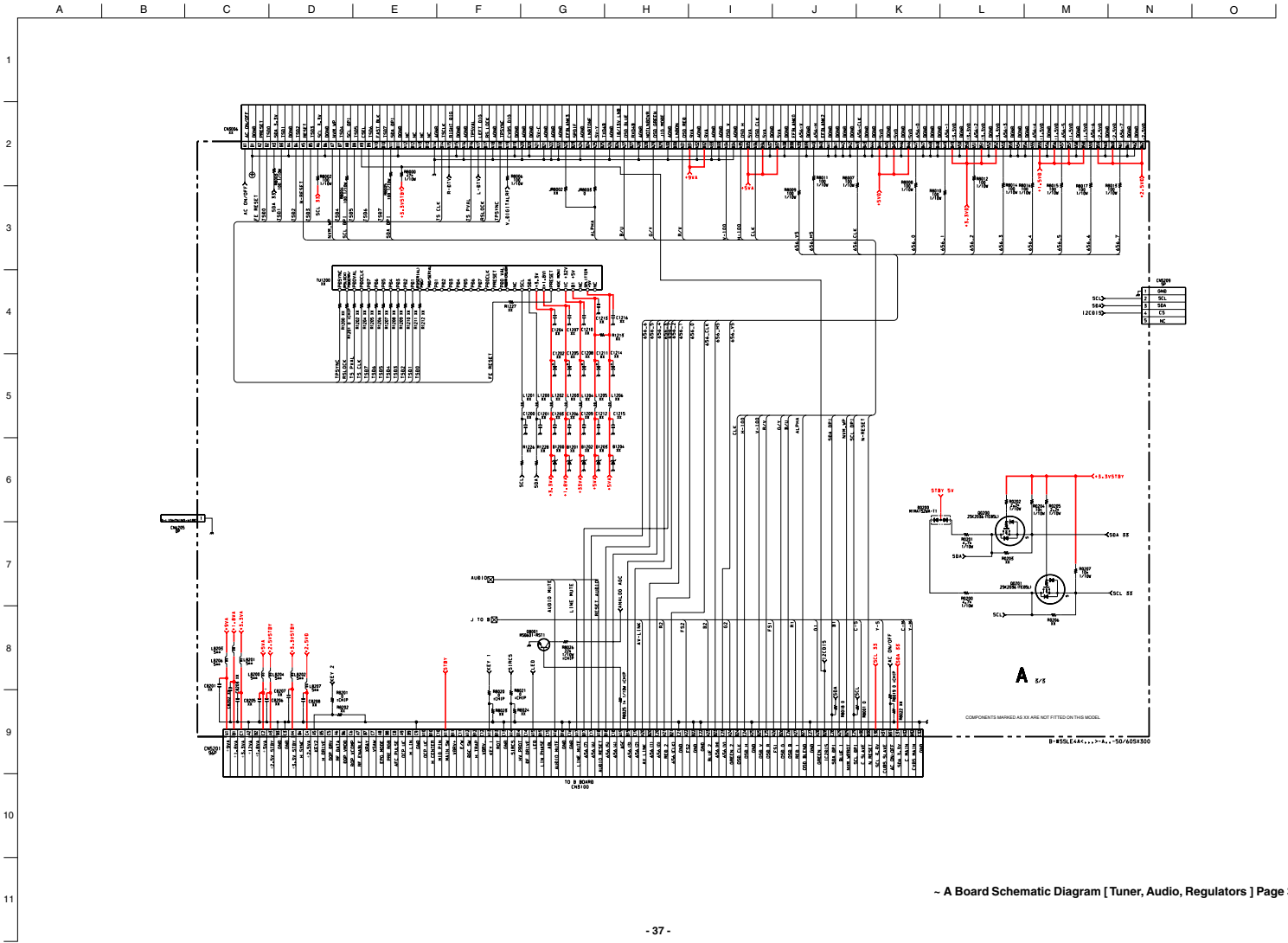

- A Board Schematic Diagram [Tuner, Audio, Regulators] Page 3/3 -

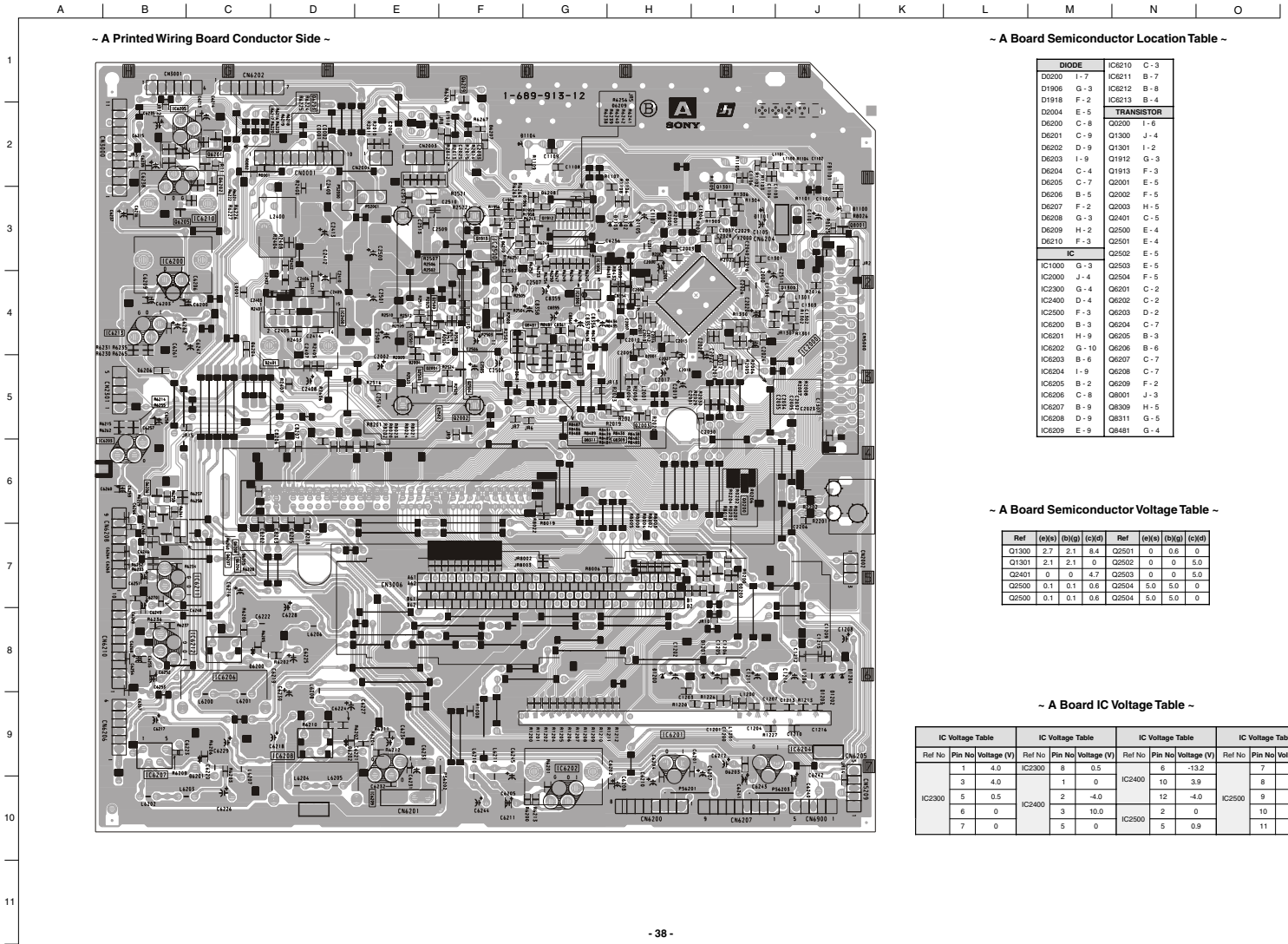

~ A Printed Wiring Board Conductor Side ~

~ A Board Semiconductor Location Table ~

DIODE		TRANSISTOR	
D0200	I-7	Q2010	C-3
D1906	G-3	IC6211	B-7
D1918	F-2	IC6212	B-8
D2004	E-5	IC6213	B-4
D6200	C-8	Q2020	I-6
D6201	C-9	Q1300	J-4
D6202	D-9	Q1301	I-2
D6203	I-8	Q1912	G-3
D6204	C-4	Q1913	F-3
D6205	C-7	Q2001	E-5
D6206	B-5	Q2002	F-5
D6207	F-2	Q2003	H-5
D6208	G-3	Q2401	C-5
D6209	H-2	Q2500	E-4
D6210	F-3	Q2501	E-4
IC			
IC1000	G-3	Q2502	E-5
IC2000	J-4	Q2504	F-5
IC2300	G-4	Q6201	C-2
IC2400	D-4	Q6202	C-2
IC2500	F-3	Q6203	D-2
IC6200	B-3	Q6204	C-7
IC6201	H-9	Q6205	B-3
IC6202	G-10	Q6206	B-6
IC6203	B-6	Q6207	C-7
IC6204	I-9	Q6208	C-7
IC6205	B-2	Q6209	F-2
IC6206	C-8	Q8001	J-3
IC6207	B-9	Q8309	H-6
IC6208	D-9	Q8311	G-5
IC6209	E-9	Q8481	G-4

~ A Board Semiconductor Voltage Table ~

Ref	(e)(k)	(b)(g)	(c)(d)	Ref	(e)(k)	(b)(g)	(c)(d)
Q1300	2.7	2.1	8.4	Q2501	0	0.6	0
Q1301	2.1	2.1	0	Q2502	0	0	5.0
Q2401	0	0	4.7	Q2503	0	0	5.0
Q2500	0.1	0.1	0.6	Q2504	5.0	5.0	0
Q2500	0.1	0.1	0.6	Q2504	5.0	5.0	0

~ A Board IC Voltage Table ~

IC Voltage Table			IC Voltage Table			IC Voltage Table			IC Voltage Table		
Ref No	Pin No	Voltage (V)	Ref No	Pin No	Voltage (V)	Ref No	Pin No	Voltage (V)	Ref No	Pin No	Voltage (V)
IC2300	1	4.0	IC2300	8	0.5	IC2400	6	-13.2	IC2500	7	0
	3	4.0		1	0		10	3.9		8	0
	5	0.5	2	-4.0	12	-4.0	9	0			
	6	0	3	10.0	5	0	10	0			
	7	0		5	0	IC2500	5	0.9		11	0

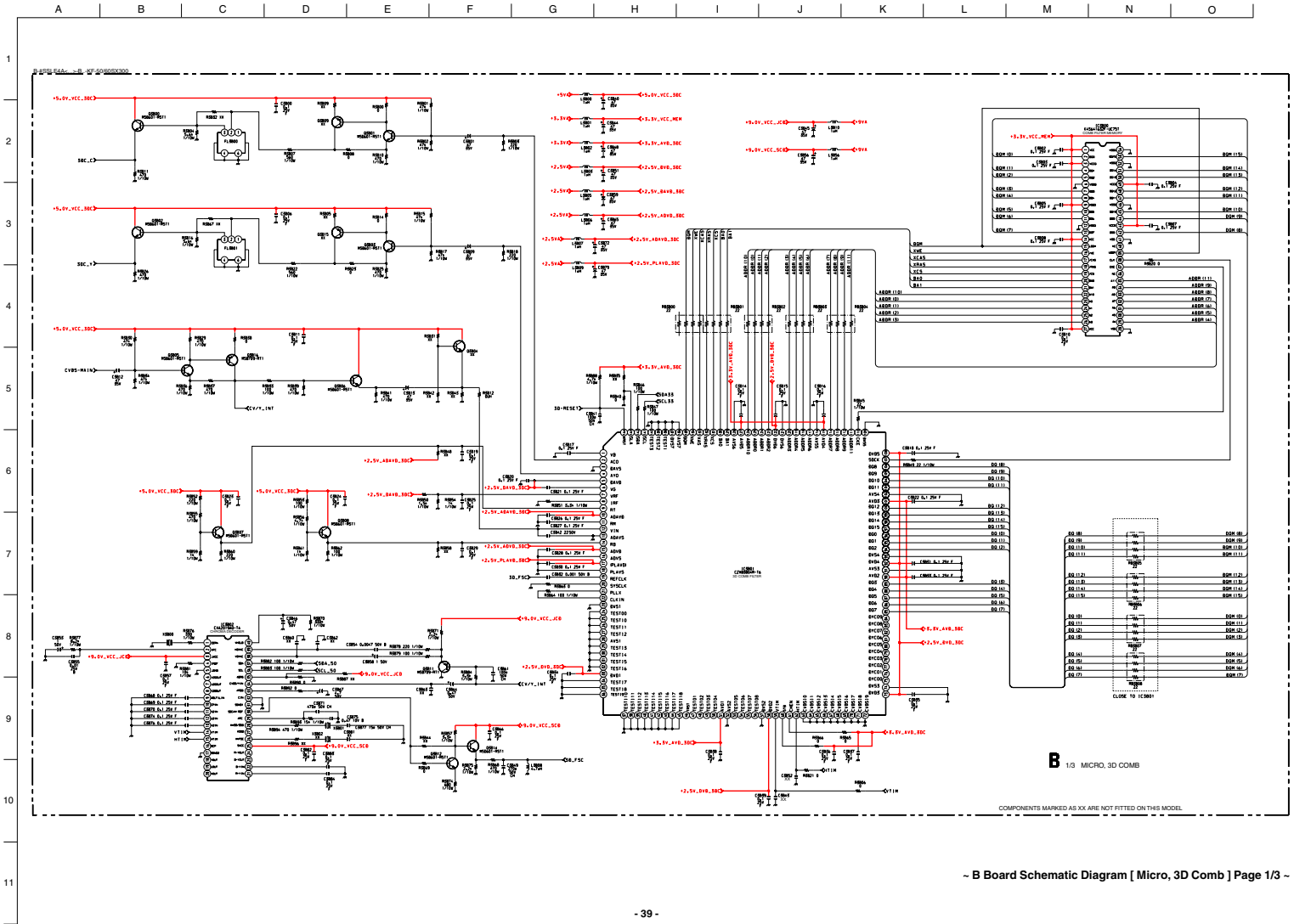

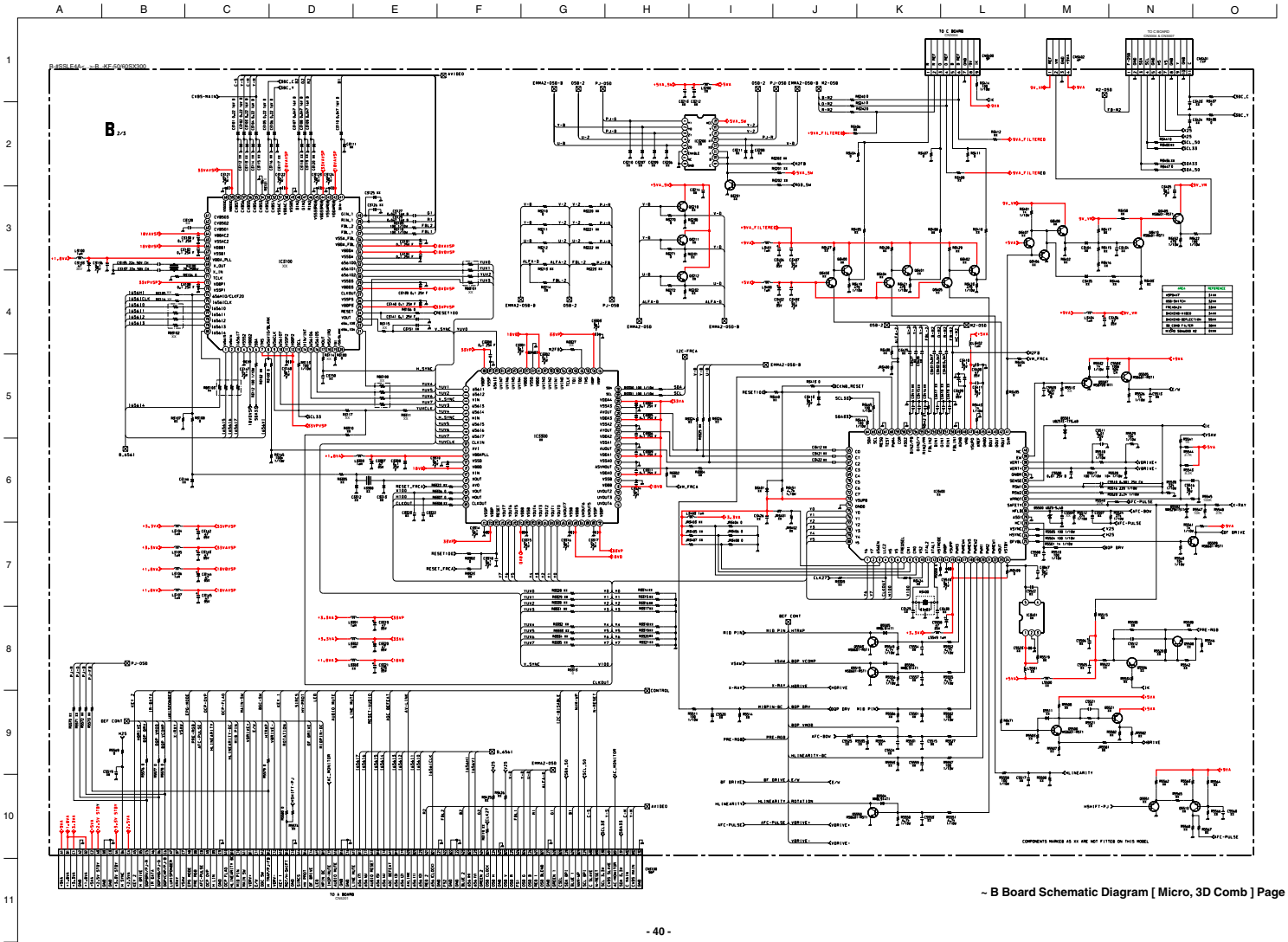

- B Board Schematic Diagram [Micro, 3D Comb] Page 2/3 -

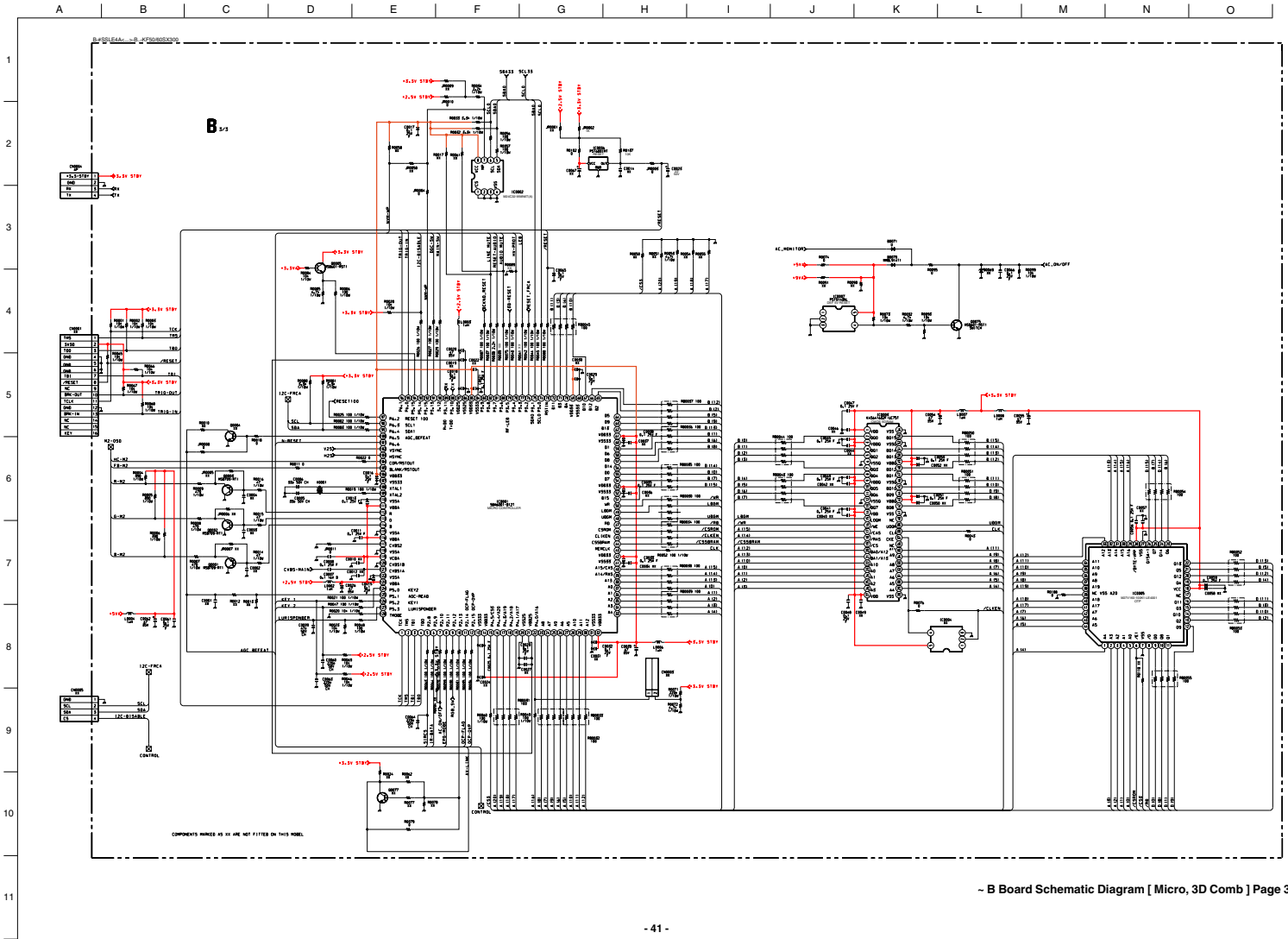

- B Board Schematic Diagram [Micro, 3D Comb] Page 3/3 -

A B C D E F G H I J K L M N O

1
2
3
4
5
6
7
8
9
10
11

- B Printed Wiring Board Conductor Side A -

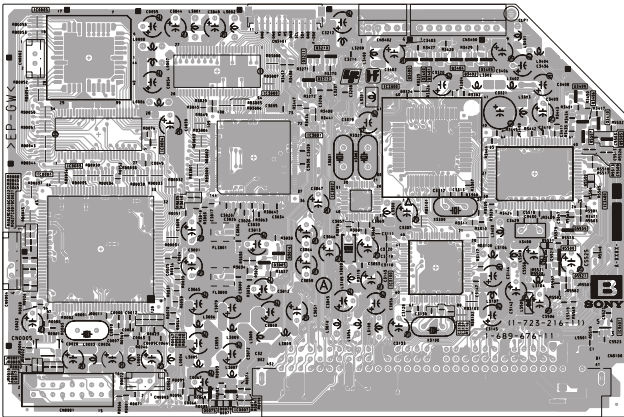

- B Board Semiconductor Location Table (A Side) -

DIODE	
D5500	G-3
IC	
IC0001	B-3
IC0003	B-3
IC0005	B-1
IC3800	D-2
IC3801	D-3
IC3802	E-3
TRANSISTOR	
Q0075	C-5
Q3409	G-2
Q3410	H-3
Q3805	D-4
Q3816	D-4
Q5500	G-4
Q5507	H-3
Q5509	G-3

- B Printed Wiring Board Conductor Side B -

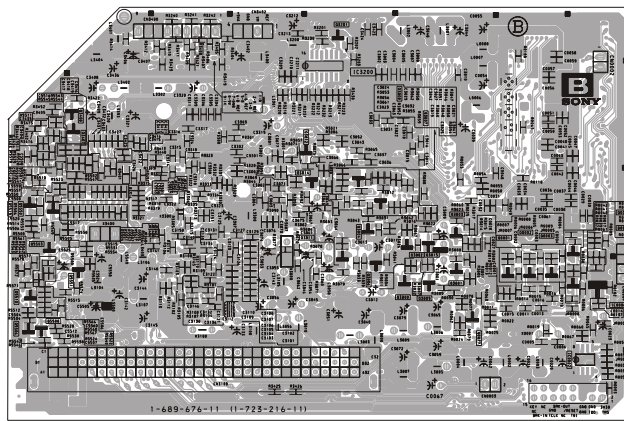

- B Board Semiconductor Location Table (B Side) -

DIODE	
D5502	B-8
IC	
IC0002	G-10
IC0006	H-10
TRANSISTOR	
Q0001	F-9
Q0002	F-9
Q0003	G-9
Q3800	E-9
Q3801	F-9
Q3802	E-9
Q3803	F-9
Q3806	E-9
Q3811	D-9
Q3812	D-8
Q3814	D-8
Q5503	B-9

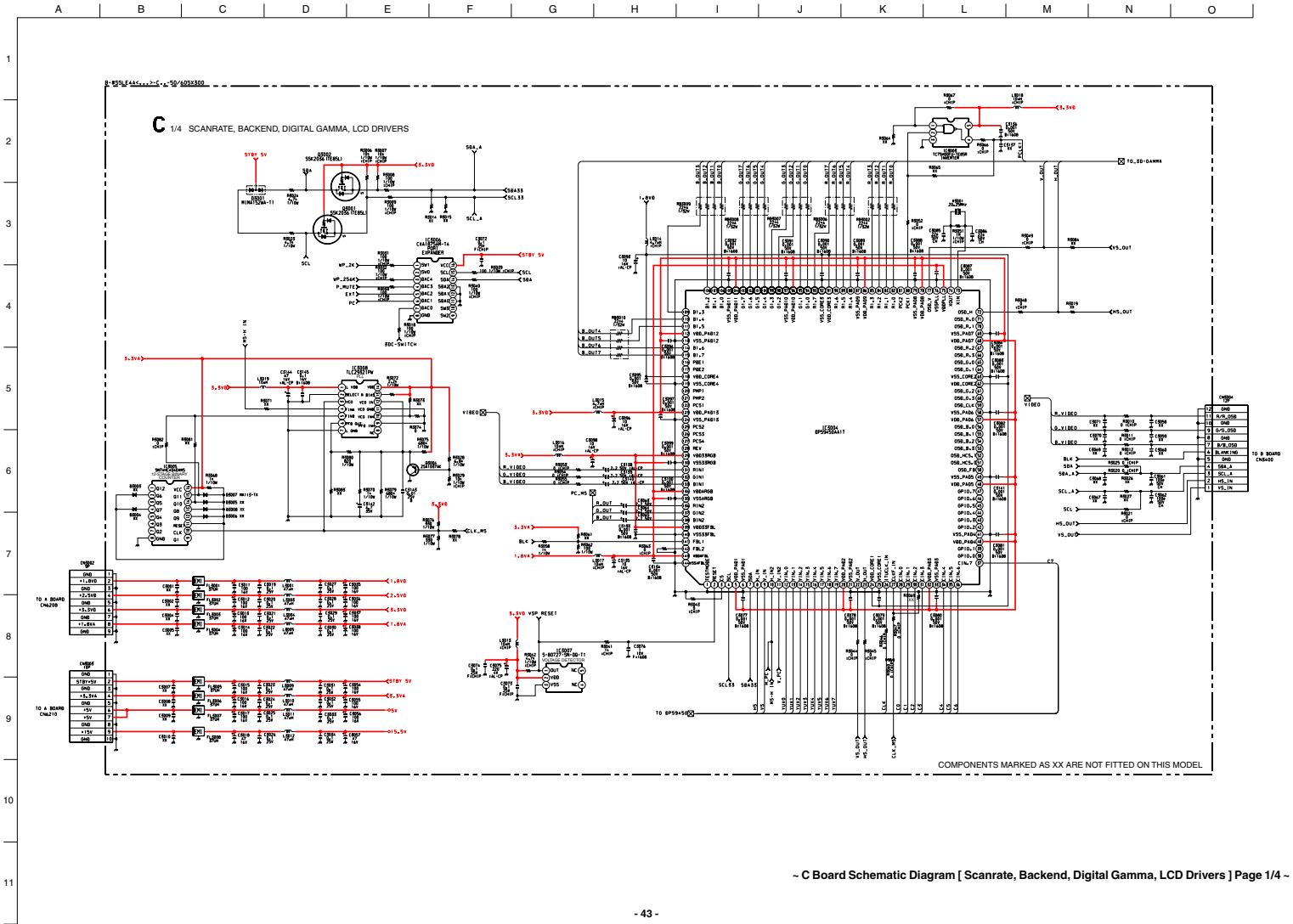

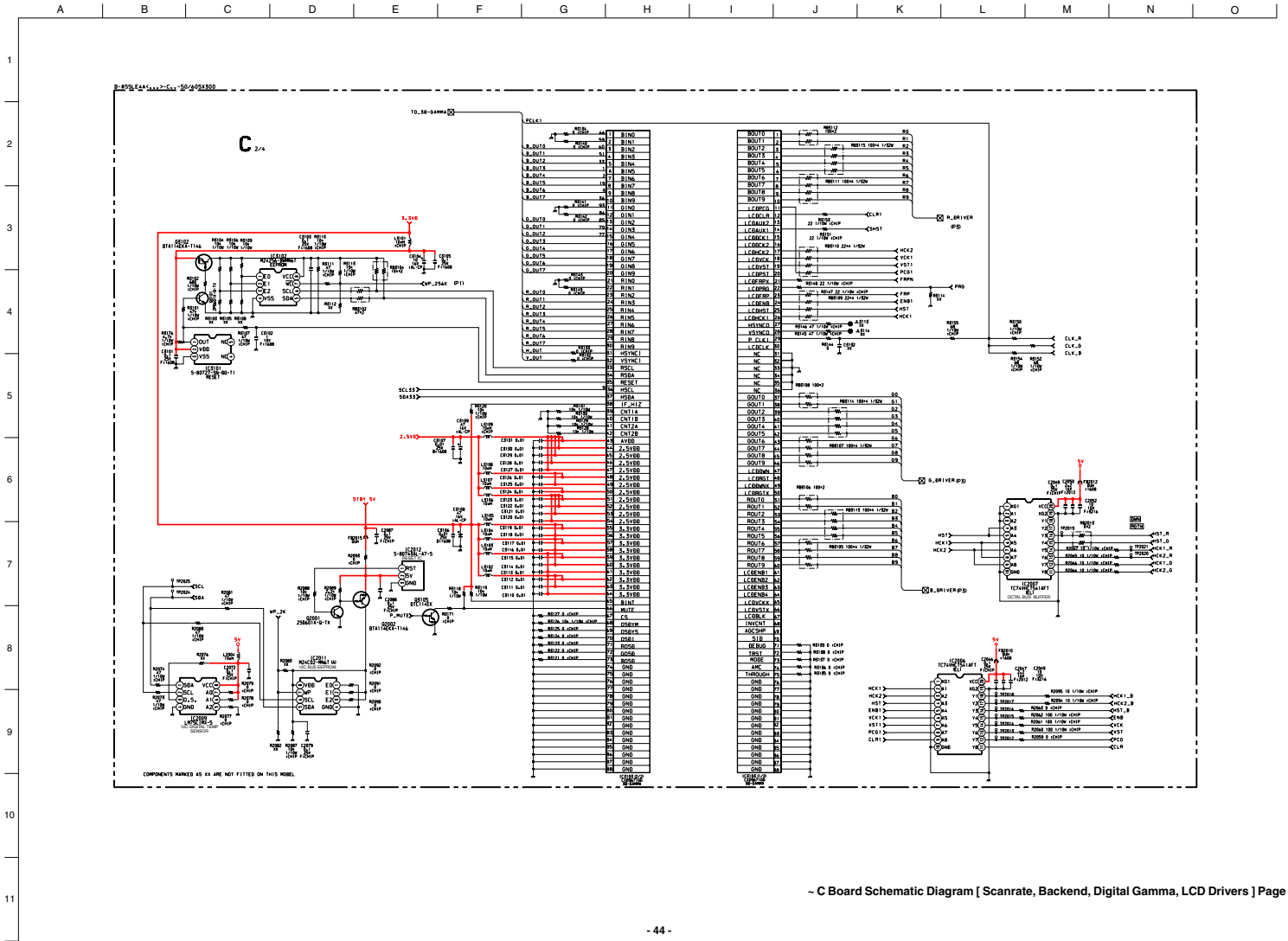

- C Board Schematic Diagram [Scanrate, Backend, Digital Gamma, LCD Drivers] Page 2/4 -

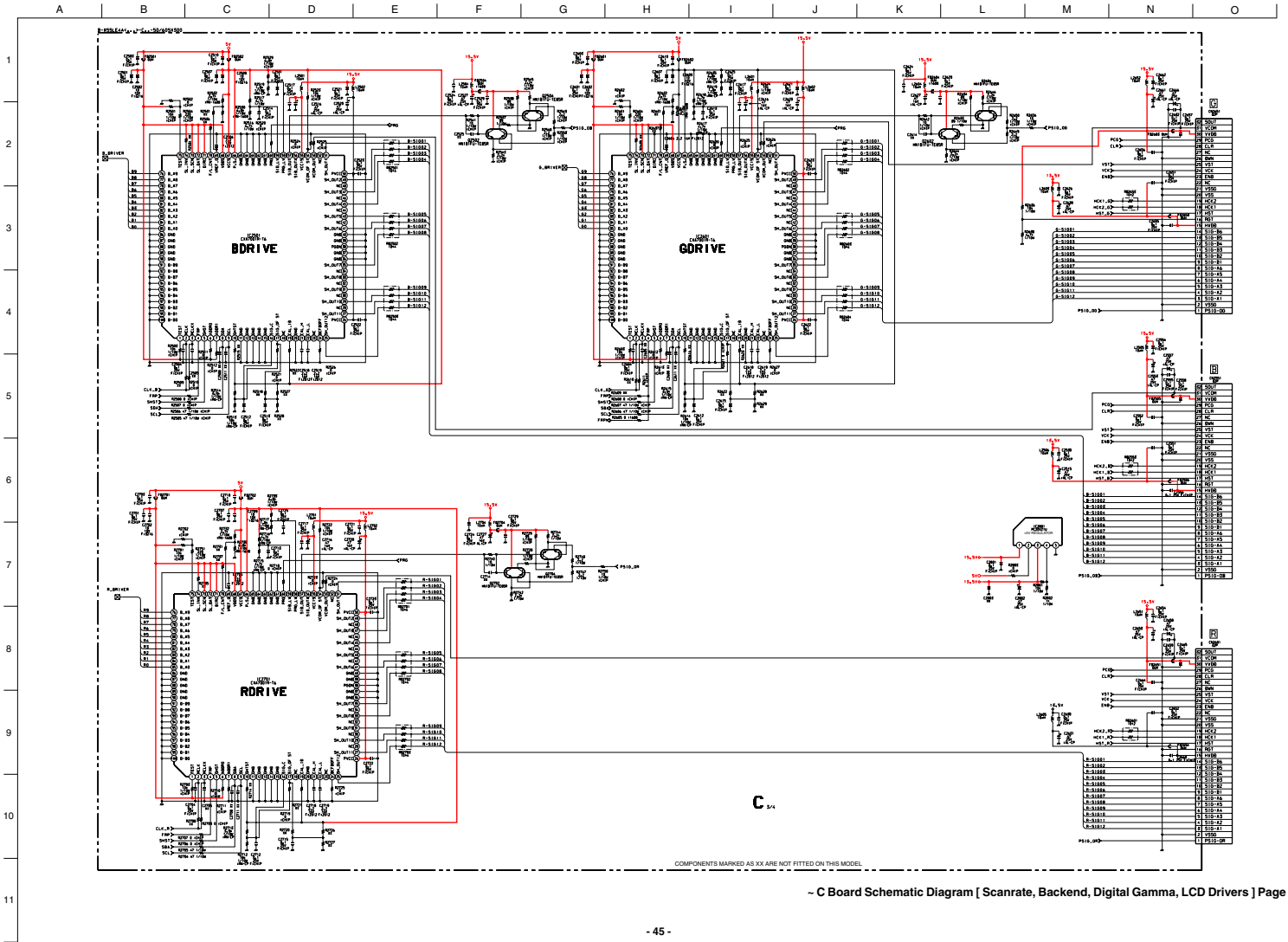

- C Board Schematic Diagram [Scanrate, Backend, Digital Gamma, LCD Drivers] Page 3/4 -

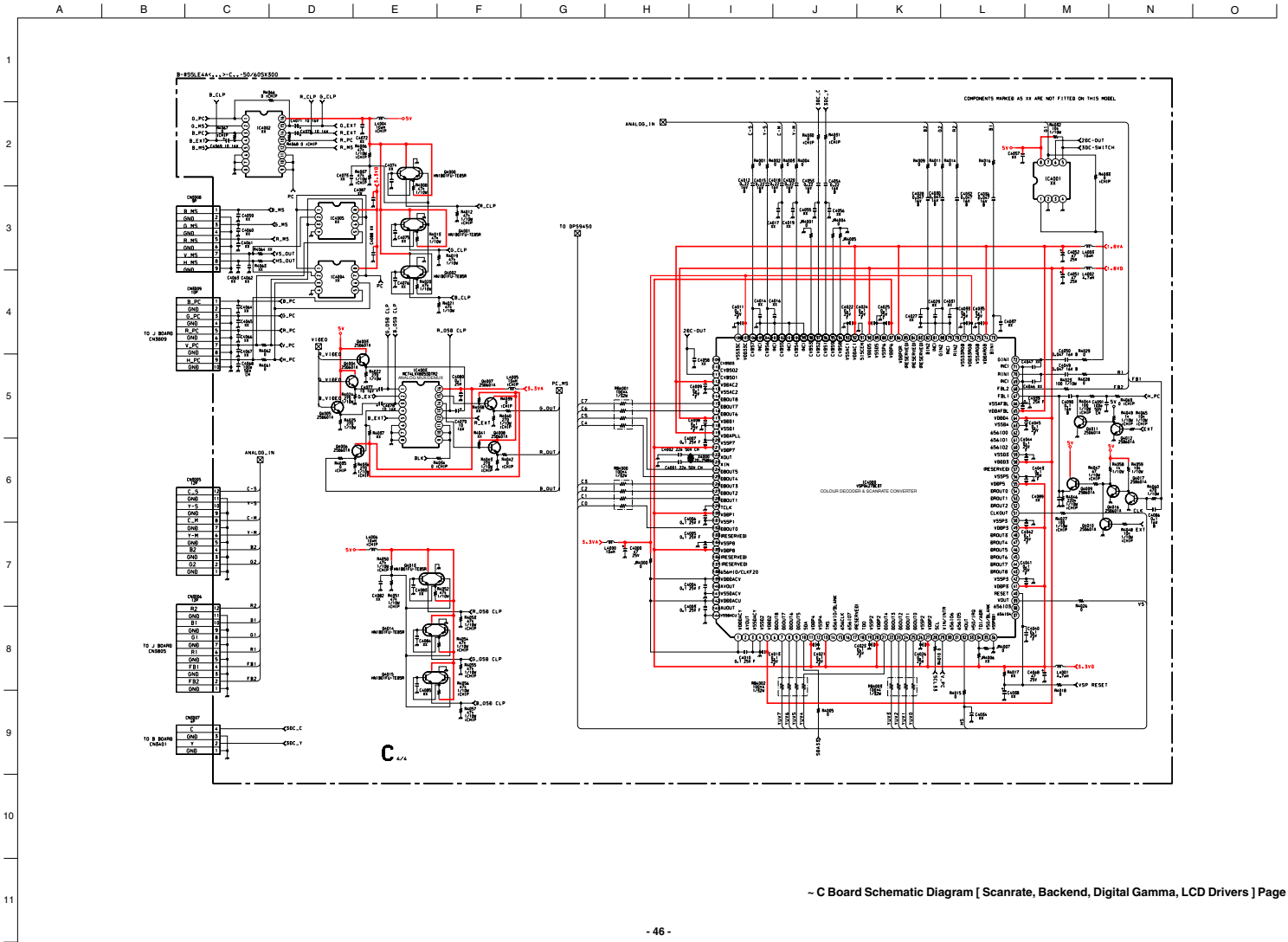

- C Board Schematic Diagram [Scanrate, Backend, Digital Gamma, LCD Drivers] Page 4/4 -

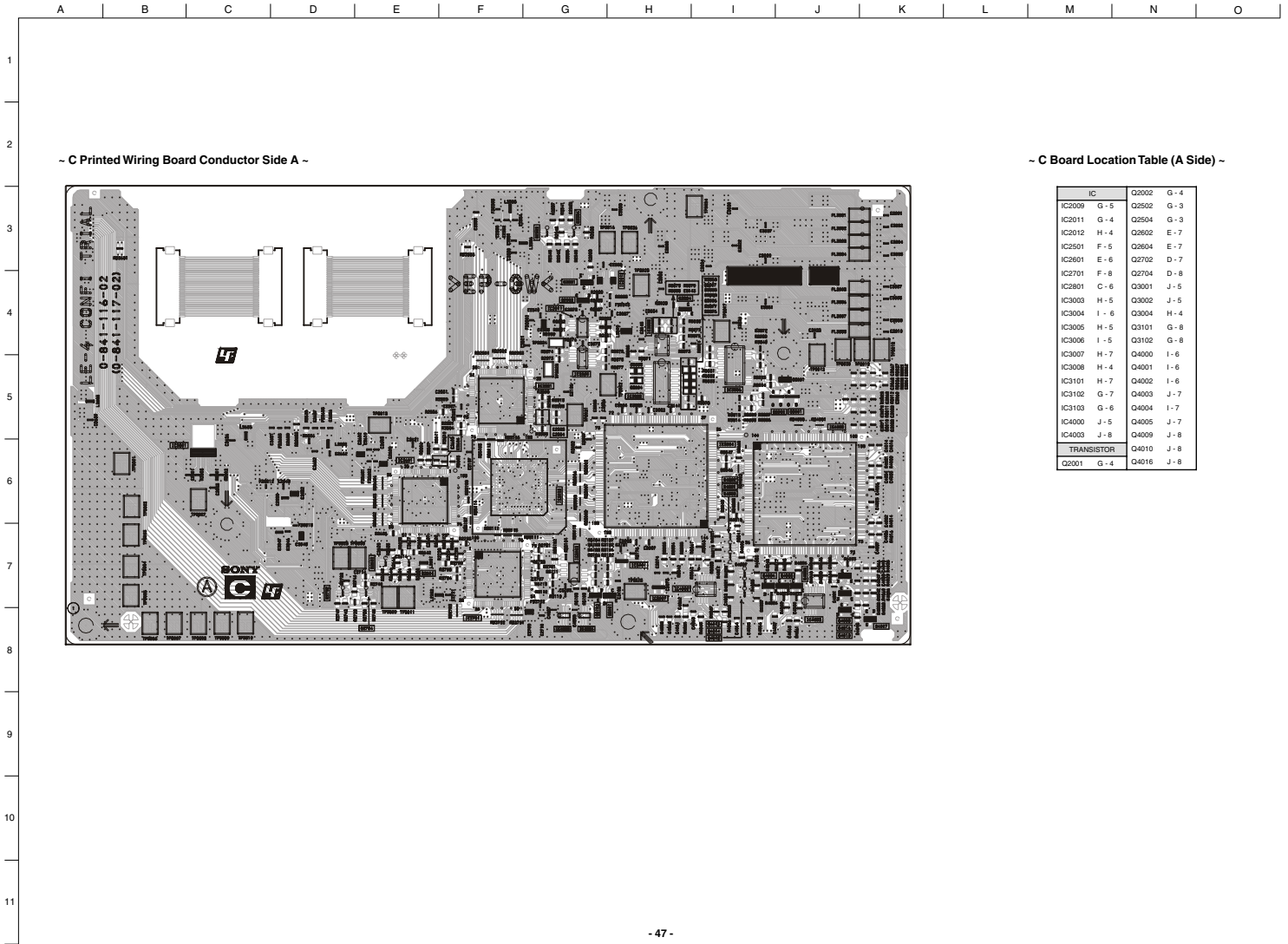

- C Printed Wiring Board Conductor Side A -

- C Board Location Table (A Side) -

IC	Q2002	G-4
IC2009	G-5	Q2502 G-3
IC2011	G-4	Q2504 G-3
IC2012	H-4	Q2602 E-7
IC2501	F-5	Q2604 E-7
IC2601	E-6	Q2702 D-7
IC2701	F-8	Q2704 D-8
IC2801	C-6	Q3001 J-5
IC3003	H-5	Q3002 J-5
IC3004	I-6	Q3004 H-4
IC3005	H-5	Q3101 G-8
IC3006	I-5	Q3102 G-8
IC3007	H-7	Q4000 I-6
IC3008	H-4	Q4001 I-6
IC3101	H-7	Q4002 I-6
IC3102	G-7	Q4003 J-7
IC3103	G-6	Q4004 I-7
IC4000	J-5	Q4005 J-7
IC4003	J-8	Q4009 J-8
TRANSISTOR		
Q2001	G-4	Q4010 J-8
		Q4016 J-8

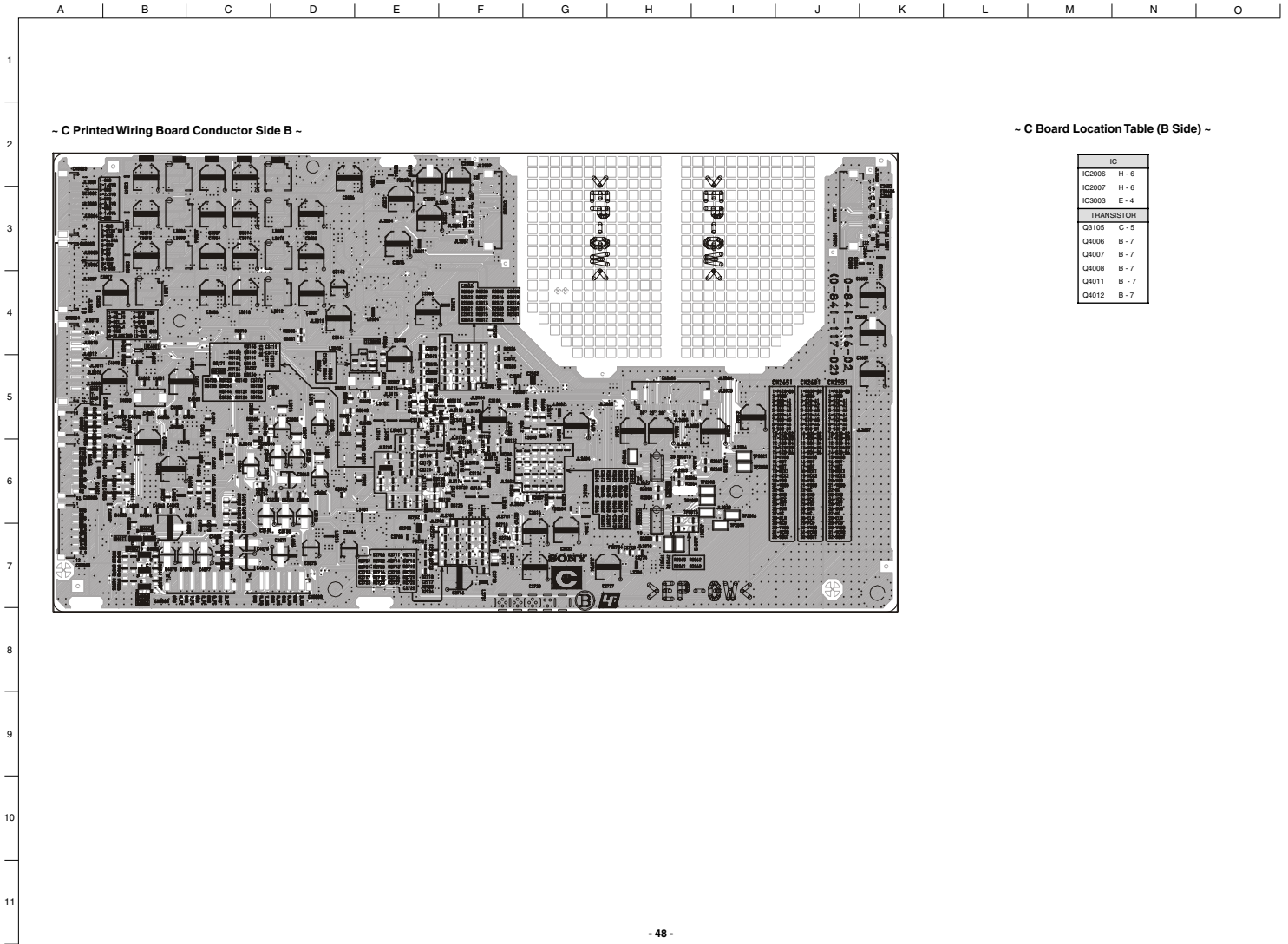

~ C Printed Wiring Board Conductor Side B ~

~ C Board Location Table (B Side) ~

IC	
IC2006	H-6
IC2007	H-6
IC3003	E-4
TRANSISTOR	
Q3105	C-5
Q4006	B-7
Q4007	B-7
Q4008	B-7
Q4011	B-7
Q4012	B-7

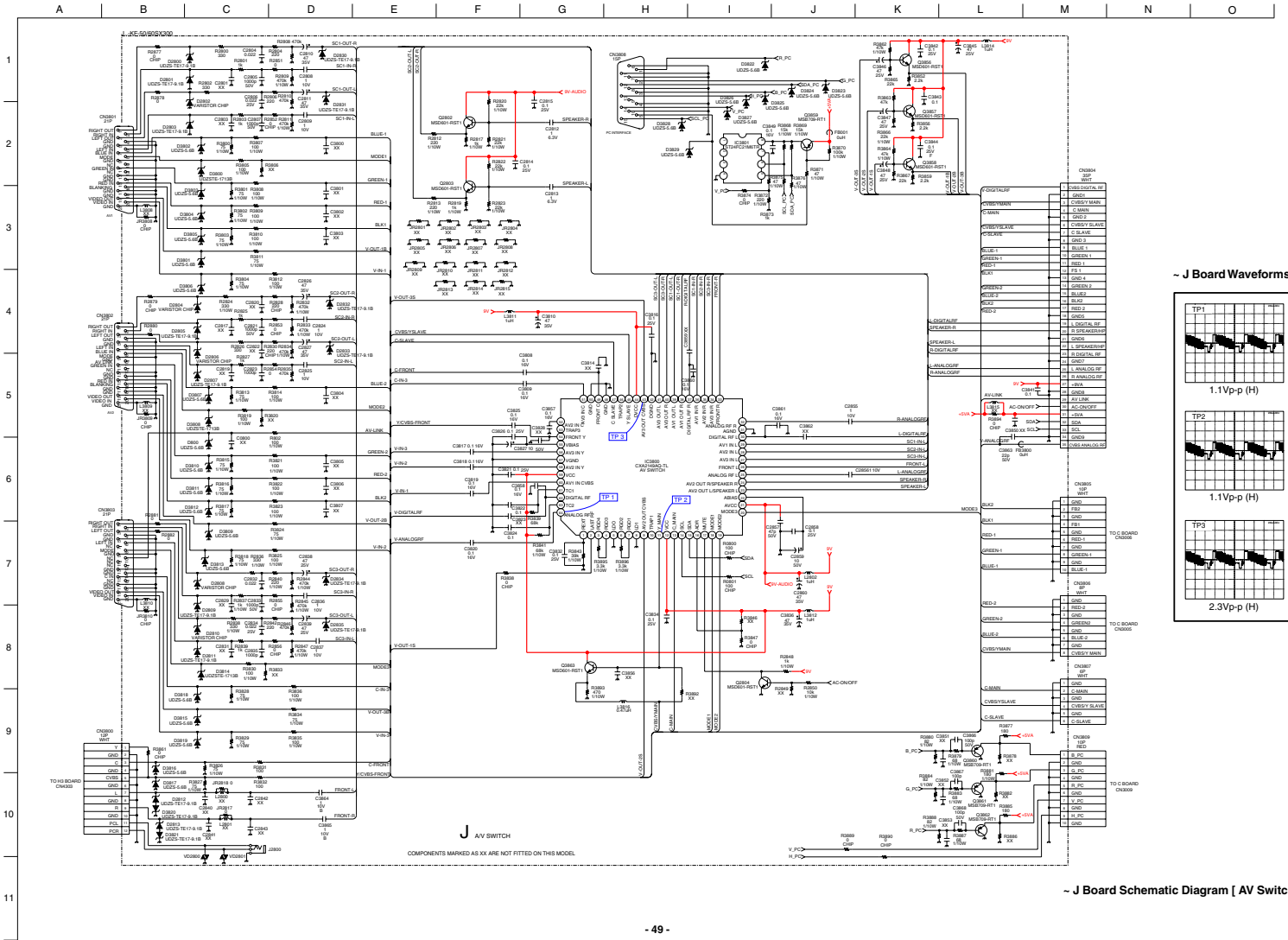

A B C D E F G H I J K L M N O

1
2
3
4
5
6
7
8
9
10
11

~ J Printed Wiring Board Conductor Side A ~

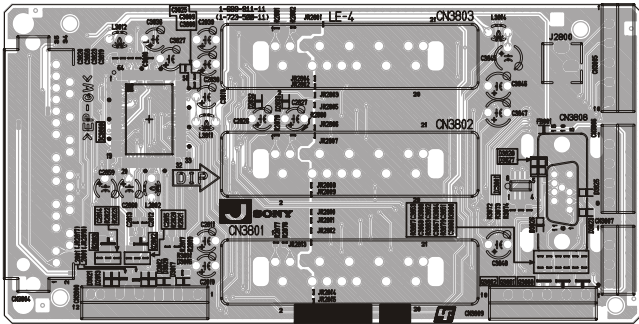

~ J Board Location Table (A Side) ~

DIODE	
D2812	C - 4
D2813	B - 4
D2832	D - 3
D2833	D - 3
D3817	C - 4
D3820	C - 4
D3821	B - 4
D3823	G - 4
D3825	G - 3
D3826	G - 4
D3827	G - 3
D3828	G - 3
IC	
IC3800	B - 3
IC3801	G - 3
TRANSISTOR	
Q2802	C - 4
Q2803	B - 4
Q3860	G - 4
Q3861	F - 4
Q3862	F - 4

~ J Board IC Voltage Table ~

IC Voltage Table			IC Voltage Table		
Ref No	Pin No	Voltage (V)	Ref No	Pin No	Voltage (V)
IC3800	1	1.9	IC3800	32	4.4
	3	4.5		33	4.4
	4	4.5		34	4.4
	5	0.1		35	4.4
	6	4.3		36	4.4
	7	4.3		37	4.4
	8	0.1		38	4.4
	9	4.6		39	4.4
	11	3.9		40	4.4
	13	4.5		41	4.4
	14	4.8		43	4.7
	15	4.8		45	4.4
	16	8.9		47	4.5
	18	0.1		49	4.5
	19	0		51	4.5
	20	0		52	4.5
	22	4.5		54	4.1
	23	4.5		55	4.5
	24	4.5		56	3.1
	25	4.5		58	4.1
	26	4.4		60	4.1
	27	4.4		61	5.1
	28	4.4		62	5.0
	29	4.4		63	4.8
	30	4.4		64	4.5

~ J Printed Wiring Board Conductor Side B ~

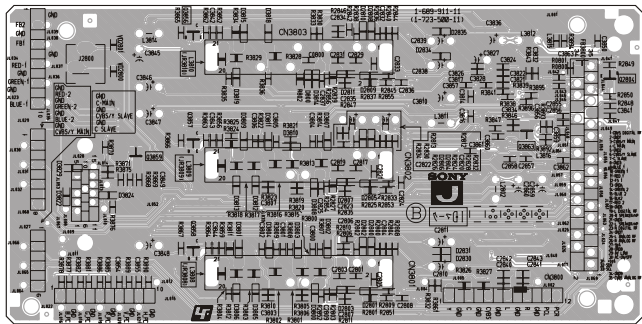

~ J Board Location Table (B Side) ~

DIODE		DIODE	
D800	D - 8	D3806	C - 10
D2800	E - 9	D3807	D - 8
D2801	D - 10	D3808	D - 9
D2802	E - 9	D3809	D - 8
D2803	D - 10	D3810	D - 8
D2804	E - 8	D3811	D - 8
D2805	E - 9	D3812	D - 9
D2806	E - 8	D3813	C - 9
D2807	E - 9	D3814	D - 8
D2808	D - 7	D3815	C - 7
D2809	D - 7	D3816	D - 7
D2810	D - 7	D3819	C - 8
D2811	D - 8	D3822	B - 9
D2830	F - 9	D3824	B - 9
D2831	F - 9	D3829	B - 8
TRANSISTOR		TRANSISTOR	
D2834	E - 7	Q2804	G - 7
D2835	F - 7	Q3856	C - 7
D3800	D - 10	Q3857	C - 8
D3801	C - 9	Q3858	C - 9
D3802	D - 9	Q3859	C - 8
D3803	D - 9	Q3863	F - 8
D3804	C - 9		

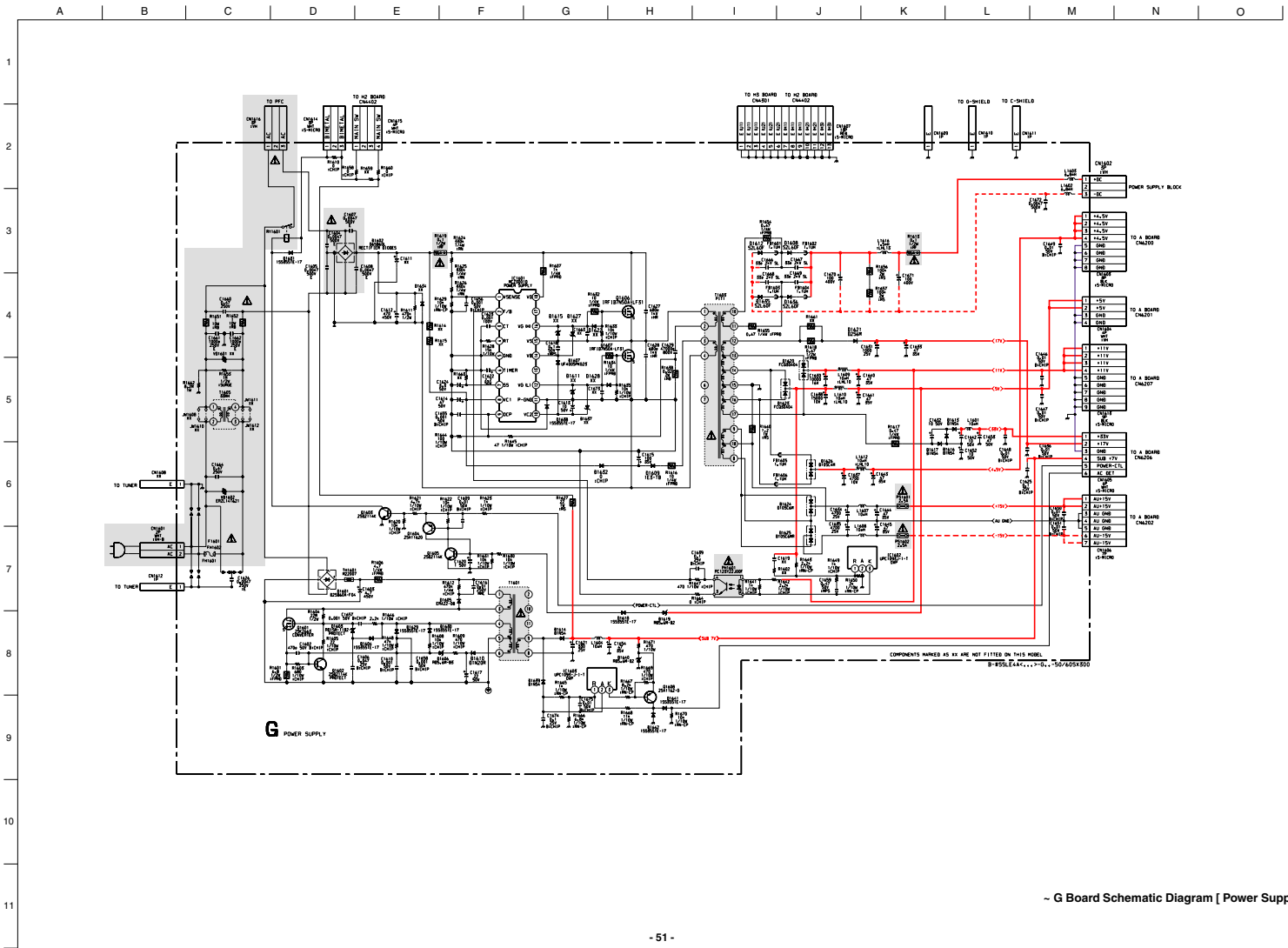

- G Board Schematic Diagram [Power Supply] -

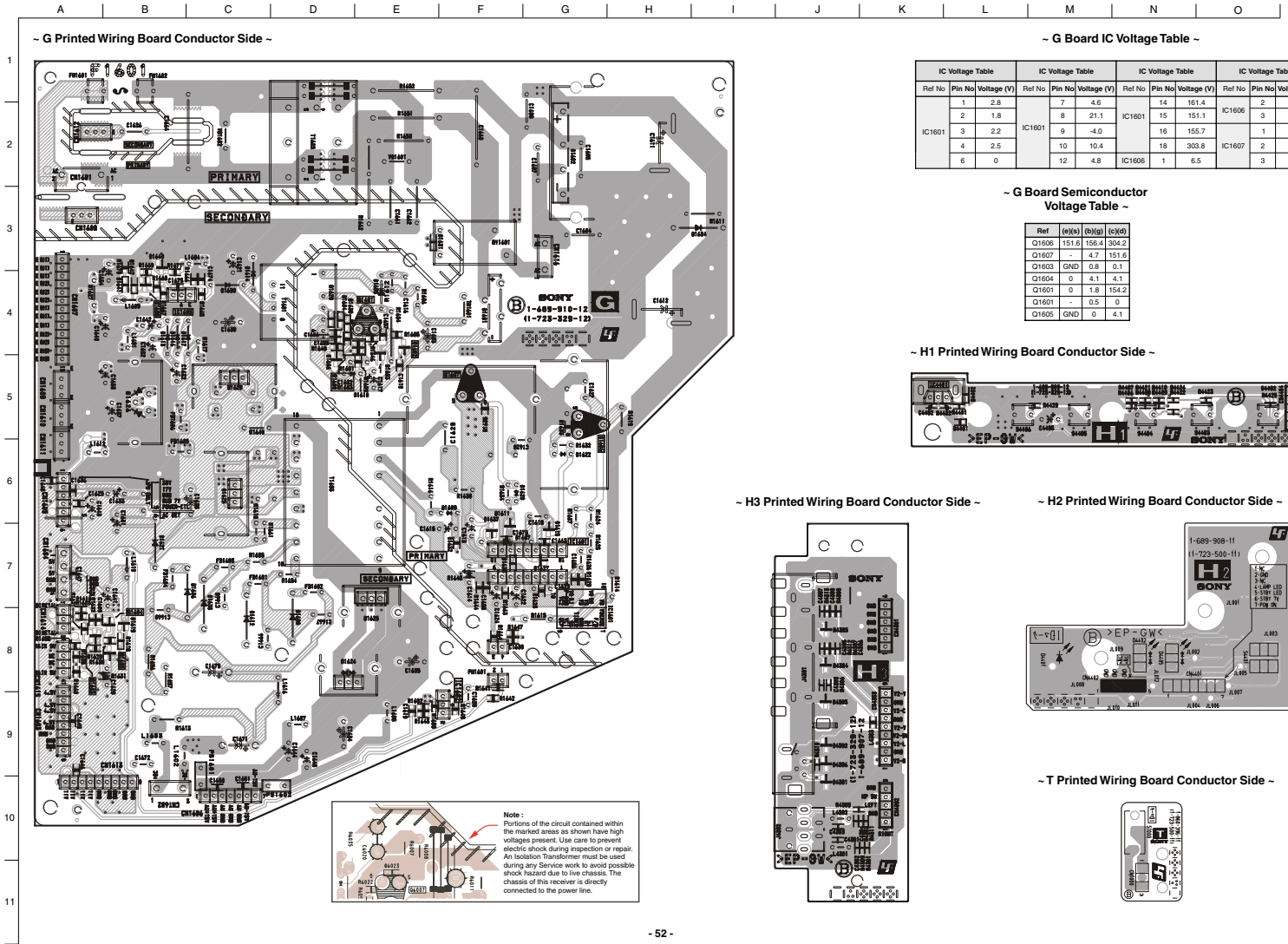

A B C D E F G H I J K L M N O

1
2
3
4
5
6
7
8
9
10
11

~ H1 Board Schematic Diagram [User Key, Sircs] ~

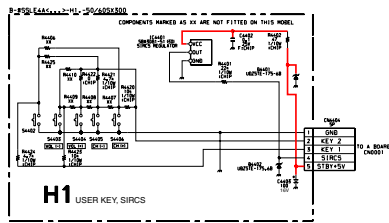

~ H2 Board Schematic Diagram [LED Indicators] ~

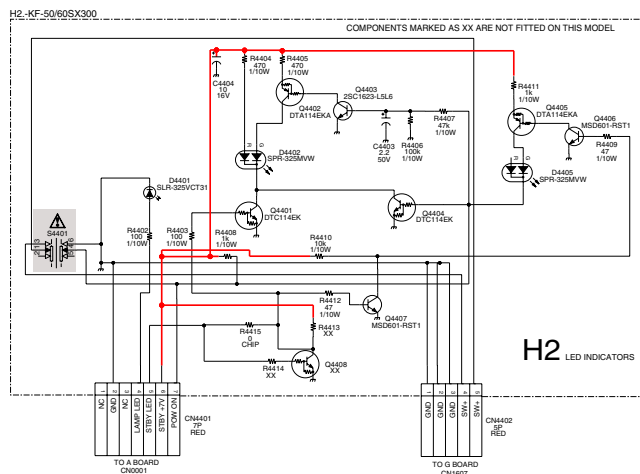

~ H3 Board Schematic Diagram [AV Input, HP Out] ~

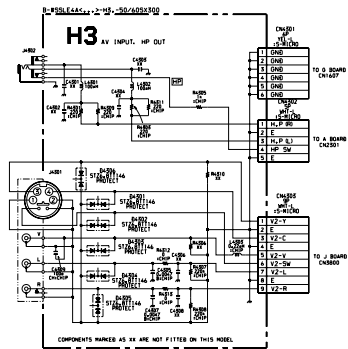

~ T Board Schematic Diagram [Lamp Cover Switch] ~

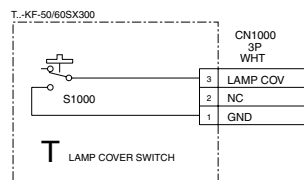

5-4. SEMICONDUCTORS

1E3-TB
D1N20R
D1NS4
ERA11-08
UF4005PKG23

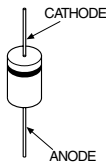

1SS355TE-17
MA113-(TX)
UDZ-TE-1713B
UDZSTE-173.6B
UDZSTE-179.1B

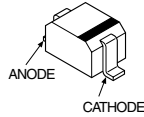

CXD3804R-T6

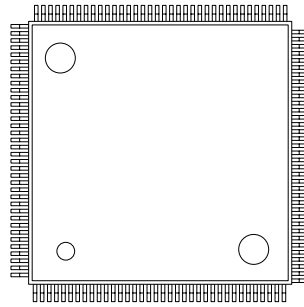

PQ1CG2032FZ

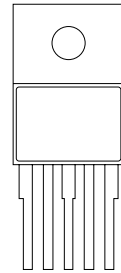

2SA1023AK-T146-R
2SA1162-G
2SC1623-L5L6
2SD2114K
DTA114EKA-T146
DTC114EK

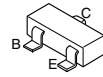

D10SC4M
D10SC6M
D10SC6MR

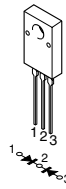

PST9143NL

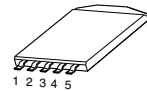

2SK2663

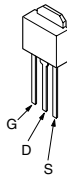

L7805CV/LSY
STP5NK40Z(033Y)
ST2310DHI

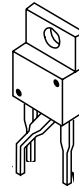

RD5.6M-B2
RD5.6M-B3

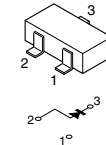

BA033T

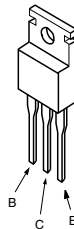

S-80743AL-47-S
S80727-SN-DQ-T1

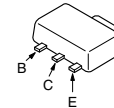

LM75C1MX-5

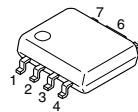

SI-8033S
SI-8050S-LF1101

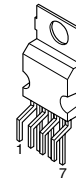

CXA1875AM-T4 (16 pin)
K4S641632F-UC75T (54 pin)
M24C32-WMN6T(A) (8 pin)
TC74VHCT541AFT(EL)
TDA2822D013TR (8 pin)
TLC2932IPWR

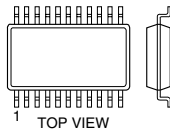

M24256-BWMN6T
M24C02-MN6T(A)

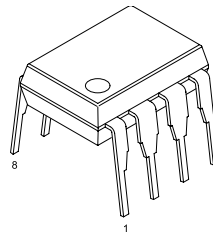

SBX3081-11

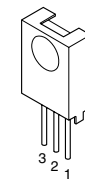

CXA2019AQ-T4 (40 pin)
CXA2149AQ-TL (64 pin)
CXA7001R (100 pin)
DSP9450AA1T (144 pin)
VSP9417BC3G (144 pin)

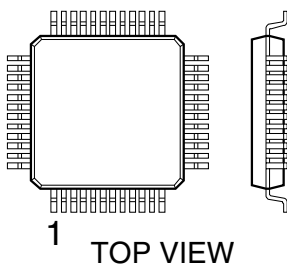

PQ30RV11



TDA7269A
TDA7482

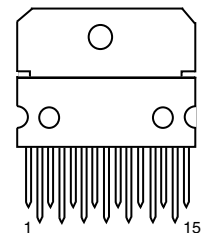

UPC1093J-1-T

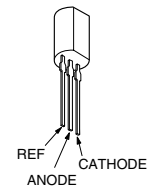

MC74LVX8053

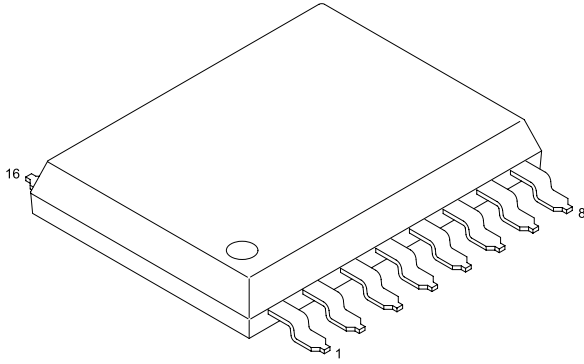

P-MQFP-128

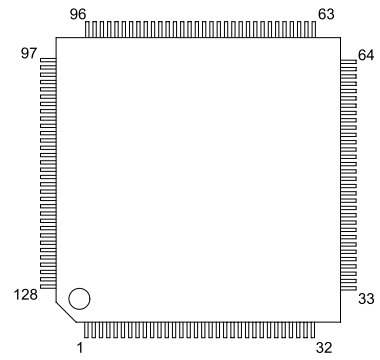

MQFP144

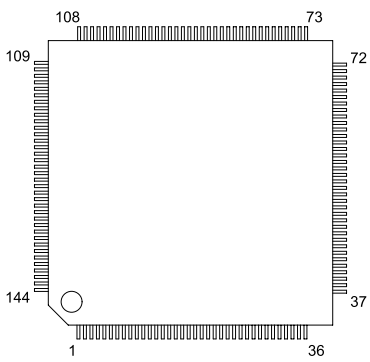

PQ20VZ-U

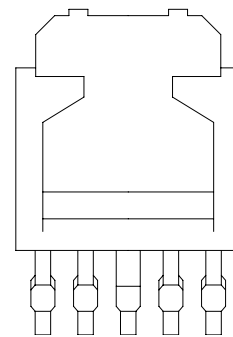

LM75

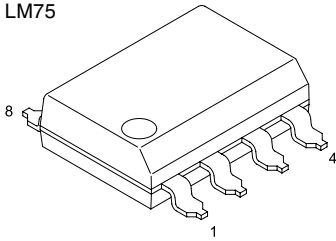

M27V160

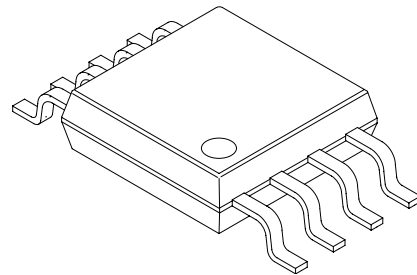

L7800

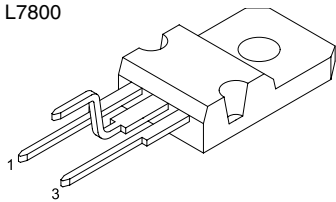

SI8050S
SI8033S

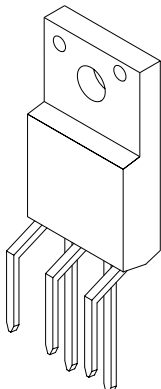

5-5 IC BLOCK DIAGRAMS

A BOARD IC2500 TDA7269

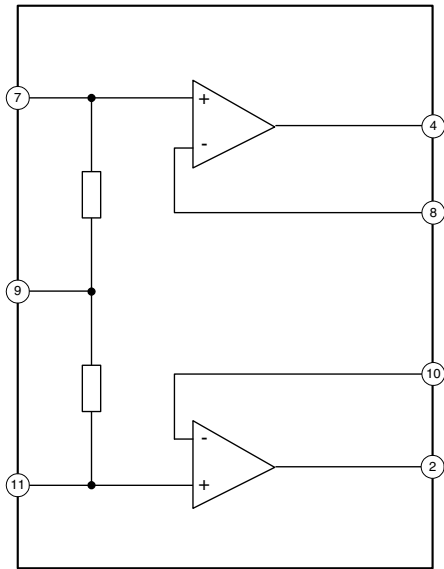

A BOARD IC6201 BA033T

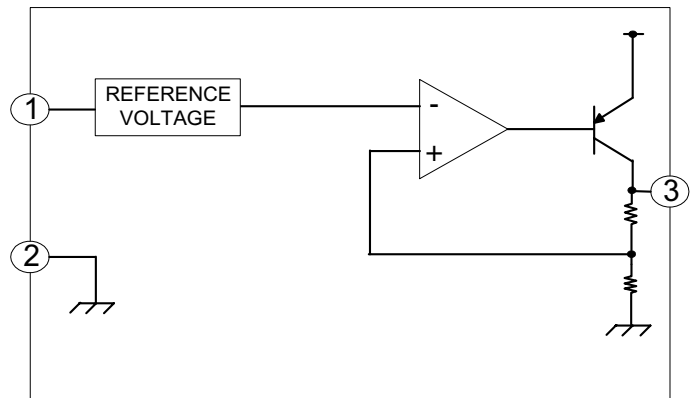

A BOARD IC6208 PQ1CG2032FZ

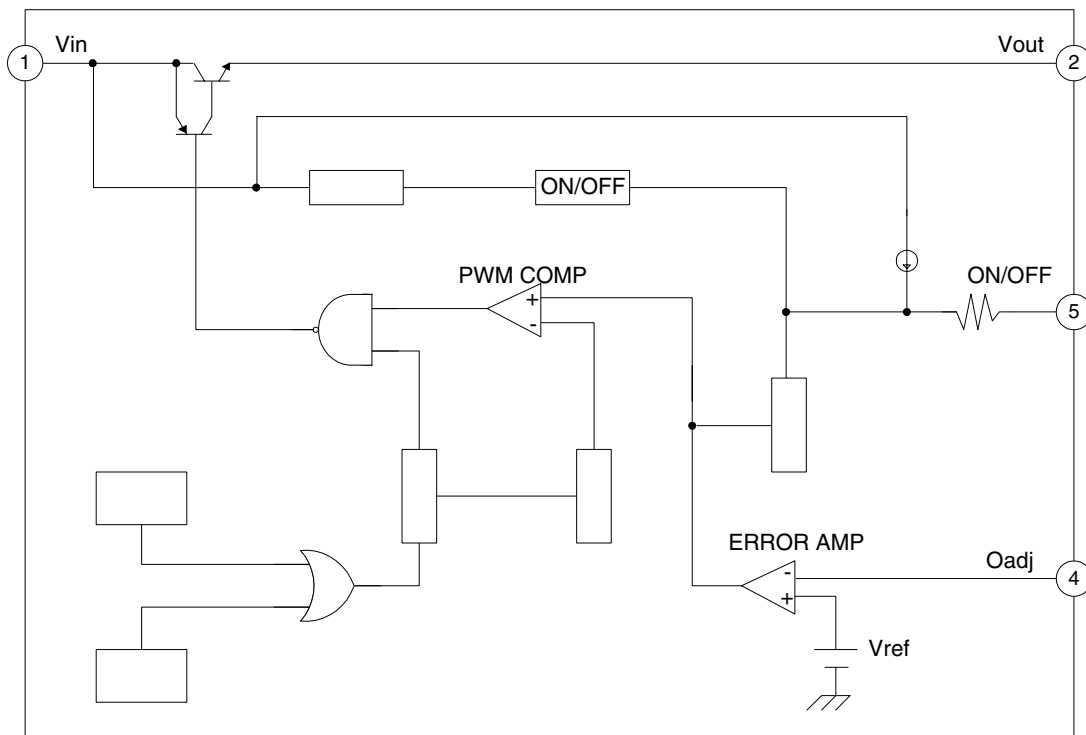

A BOARD IC2000 MSP3411G

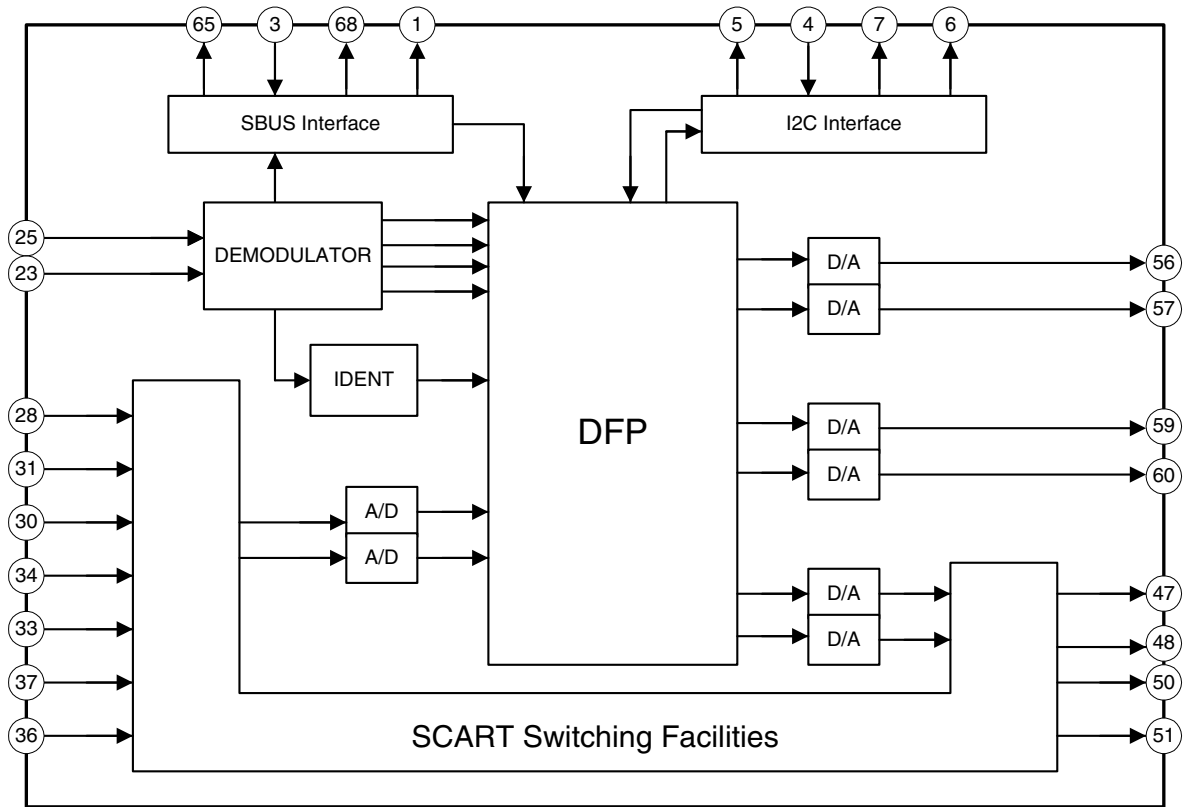

G BOARD IC1601 MCZ3001D

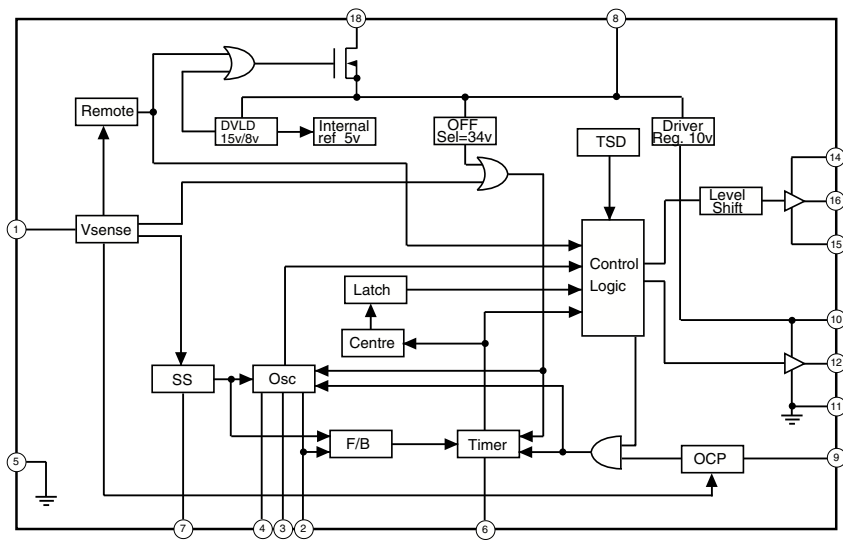

SECTION 6 EXPLODED VIEWS

NOTE :

- Items with no part number and no description are not stocked because they are seldom required for routine service.
- The construction parts of an assembled part are indicated with a collation number in the remarks column.
- Items marked “*” are not stocked since they are seldom required for routine service. Some delay should be anticipated when ordering these items.

The components identified by shading and mark Δ are critical for safety. Replace only with part number specified.

6-1. SCREEN AND COVER BLOCK

- : 7-685-648-79 SCREW (WASHER HEAD) (+P4X35)
- Δ : 7-685-658-79 SCREW +BVTP 3X12 TYPE 2 IT-3
- : 7-685-663-79 SCREW +BVTP 4X16 TYPE 2 IT-3
- : 7-685-663-71 SCREW +BVTP 3X14 TYPE 2 IT-3

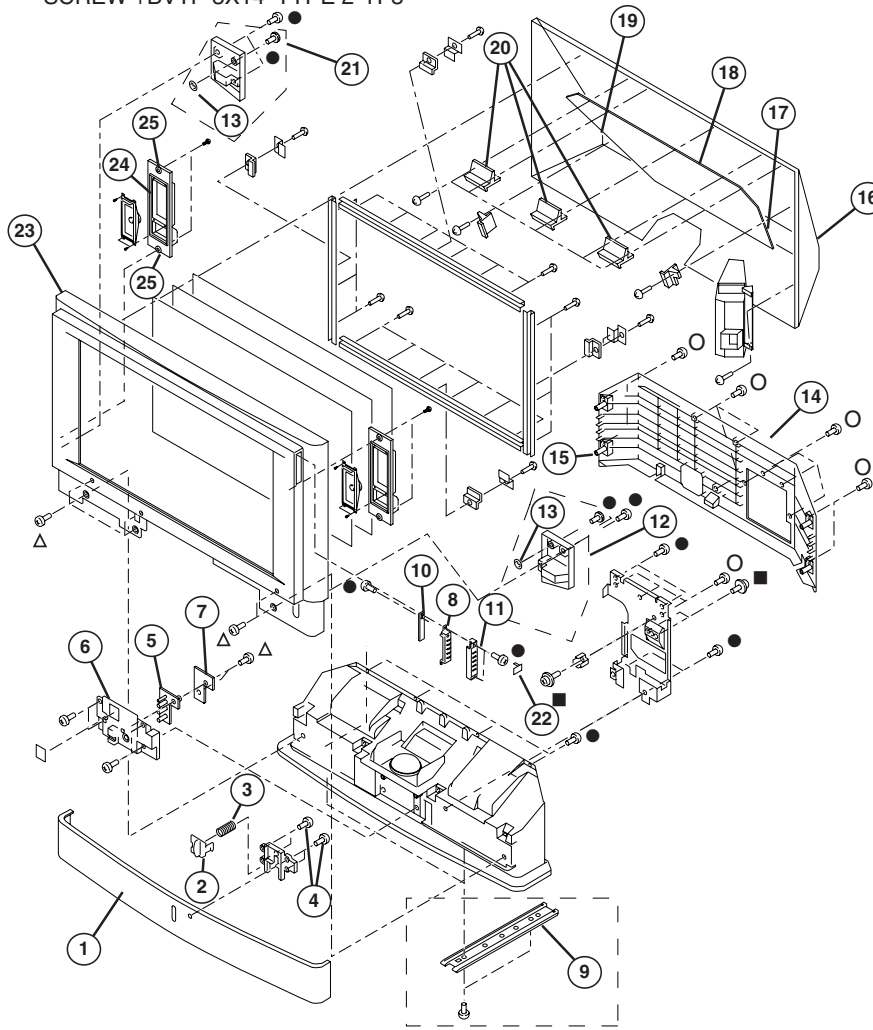

REF.NO.	PART.NO	DESCRIPTION	REMARK	REF.NO.	PART.NO	DESCRIPTION	REMARK
1	X-4041-950-1	COVER ASSY, FRONT (KF-50SX300)		14	4-094-695-31	COVER, REAR (KF-50SX300)	
	X-4041-958-1	COVER ASSY, FRONT (KF-60SX300)			4-094-695-41	COVER, REAR (KF-60SX300)	
2	4-094-706-01	BUTTON, POWER		15	1-825-580-11	LOUDSPEAKER (10CM)	
3	4-036-405-01	SPRING, COMPRESSION		16	X-4041-944-1	COVER (50) ASSY, MIRROR (KF-50SX300)	
4	7-685-648-79	SCREW +BVTP 3X12 TYPE2 IT-3			X-4041-954-1	COVER (60) ASSY, MIRROR (KF-60SX300)	
5	4-094-707-01	GUIDE (LED), LIGHT		17	4-077-752-02	HOLDER (L), MIRROR	
6	4-095-607-11	BRACKET, H2		18	4-078-871-01	MIRROR (50) (KF-50SX300)	
7	A-1405-808-A	MOUNTED PC BOARD, H2			4-097-650-01	MIRROR (60) (KF-60SX300)	
8	4-094-712-01	BUTTON, H1		19	4-077-731-02	HOLDER (R), MIRROR	
9	X-4042-014-2	PLATE (50) ASSY, FOOT (KF-50SX300)		20	4-077-669-01	HOLDER (U), MIRROR	
	X-4042-015-2	PLATE (60) ASSY, FOOT (KF-60SX300)		21	X-4041-951-1	CAP REAR (R), ASSY	
10	A-1405-807-A	MOUNTED PC BOARD, H1		22	4-099-706-01	CAP H1 (PAINTED)	
11	4-099-707-01	BRACKET H1 (PAINTED)		23	A-1604-990-A	FRAME (50) ASSY, SCREEN (KF-50SX300)	
12	X-4041-952-1	CAP REAR (L), ASSY			A-1605-715-A	FRAME (60) ASSY, SCREEN (KF-60SX300)	
13	3-650-537-00	WASHER		24	1-544-857-11	SPEAKER (13X7CM)	
				25	4-058-870-01	SCREW	

6-2. CABINET BLOCK

The components identified by shading and mark Δ are critical for safety. Replace only with part number specified.

Δ : 7-685-658-79 SCREW +BVTP 3X12 TYPE 2 IT-3

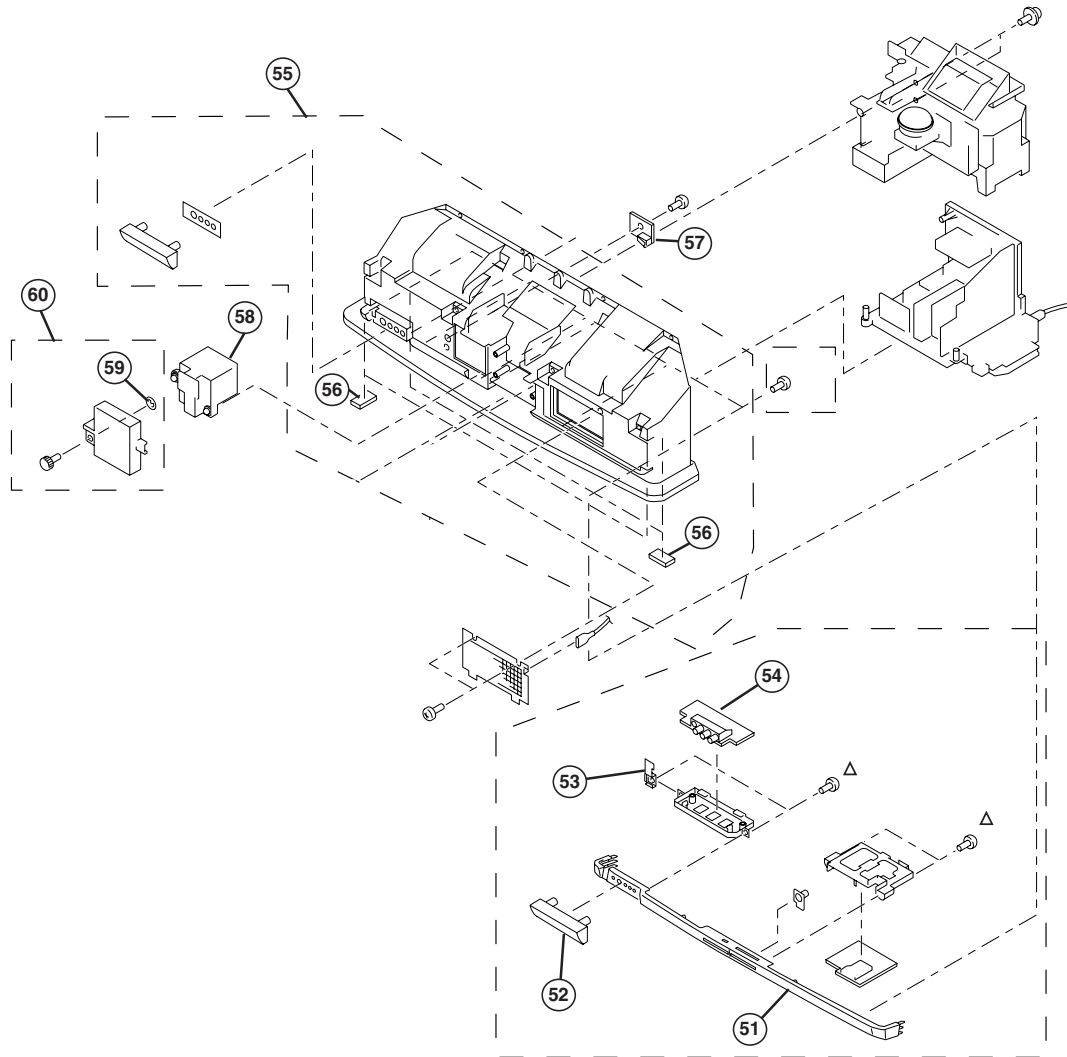

REF.NO.	PART.NO	DESCRIPTION	REMARK	REF.NO.	PART.NO	DESCRIPTION	REMARK
51	4-094-723-21	COVER, BOTTOM		56	4-097-548-01	CUSHION, FOOT	
52	4-098-512-01	DOOR, H3		57	*A-1405-811-A	MOUNTED PC BOARD, T	
53	4-094-757-01	SPRING, PLATE		58	A-1606-075-A	LAMP BLOCK ASSY	
54	*A-1405-806-A	MOUNTED PC BOARD, H3		59	*3-650-537-00	WASHER	
55	X-4041-946-1	CABINET (50) ASSY (KF-50SX300)		60	4-094-747-11	DOOR, LAMP	
	X-4041-956-1	CABINET (60) ASSY (KF-60SX300)					

6-3. MAIN BRACKET BLOCK

The components identified by shading and mark Δ are critical for safety. Replace only with part number specified.

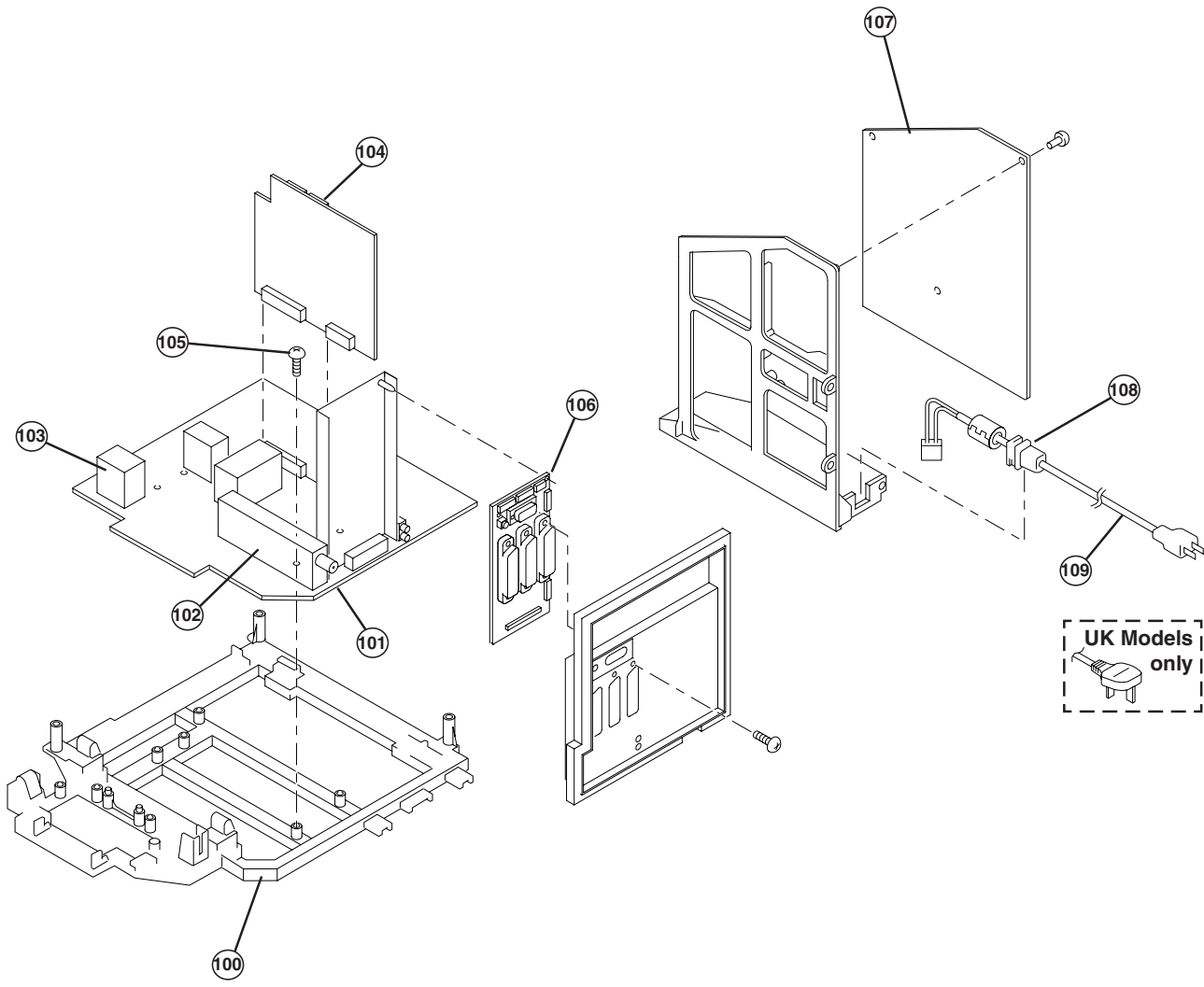

REF.NO.	PART.NO	DESCRIPTION	REMARK	REF.NO.	PART.NO	DESCRIPTION	REMARK
100	4-096-934-11	BRACKET, MAIN		107	*A-1302-408-A	COMPLETE PC BOARD, G	
101	*A-1405-803-A	MOUNTED PC BOARD, A		108	4-065-070-01	HOLDER, AC CORD	
102	8-598-535-20	FRONT END BTF-EF411		109	Δ 1-765-286-11	CORD, POWER (KF-50SX300K/KF-50SX300AEP/ KF-60SX300K/KF-60SX300AEP)	
103	1-419-965-11	COIL, CHOKE 27.0MMH			Δ 1-776-860-11	POWER CORD, FILTER (UK) (KF-50SX300U/ KF-60SX300U)	
104	*H-8001-379-A	MOUNTED PC BOARD, B (VAR)					
105	7-685-663-79	SCREW +BVTP 4X16 TYPE2 IT-3					
106	*A-1405-804-A	MOUNTED PC BOARD, J					

6-4. PICTURE TUBE BLOCK

The components identified by shading and mark Δ are critical for safety. Replace only with part number specified.

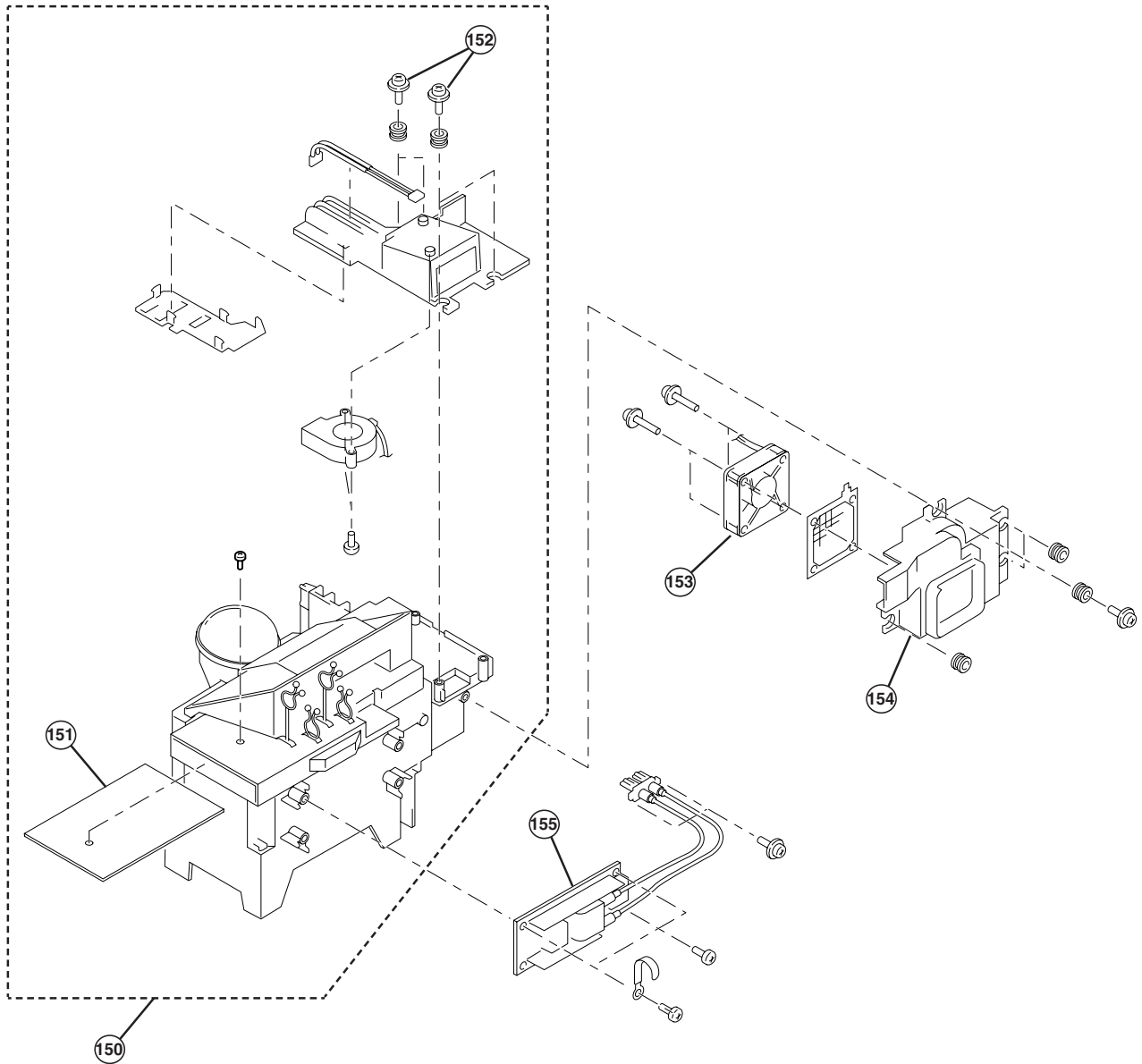

REF.NO.	PART.NO	DESCRIPTION	REMARK	REF.NO.	PART.NO	DESCRIPTION	REMARK
150	A-1604-992-A	OPTICS UNIT BLOCK ASSY		153	1-787-057-11	D.C. FAN	
151	A-1302-407-A	COMPLETE PC BOARD, C		154	1-418-257-11	FAN UNIT, DC	
152	4-319-520-11	SCREW, SPECIAL (+PW4X30)		155	Δ 1-468-798-11	POWER SUPPLY BLOCK	

SECTION 7 ELECTRICAL PARTS LIST

PARTS LISTING TABLE OF CONTENTS

	<u>Page</u>
B BOARD COMPLETE Parts List :	63
A BOARD COMPLETE Parts List :	68
J BOARD COMPLETE Parts List :	73
T BOARD COMPLETE Parts List :	76
G BOARD COMPLETE Parts List :	76
H1 BOARD COMPLETE Parts List :	79
H2 BOARD COMPLETE Parts List :	79
H3 BOARD COMPLETE Parts List :	80
C BOARD COMPLETE Parts List :	80
MISCELLANEOUS :	88
ACCESSORIES AND PACKAGING MATERIALS :	88
REMOTE COMMANDER:	88

Note : Refer to the designated variant parts list when seeking a part indicated by an asterisk (*)
Parts indicated (XX) on the Schematic Diagram are not used in this model and
therefore do not appear in the Parts List.

REF.NO.	PART.NO	DESCRIPTION	REMARK	REF.NO.	PART.NO	DESCRIPTION	REMARK
* H-8001-379-A B Board Complete				C3106	1-127-715-91	CERAMIC CHIP 0.22UF	10% 16V
< CAPACITOR >				C3107	1-165-176-11	CERAMIC CHIP 0.047UF	10.00% 16V
C0005	1-162-921-11	CERAMIC CHIP 33PF	5.00% 50V	C3108	1-165-176-11	CERAMIC CHIP 0.047UF	10.00% 16V
C0006	1-162-921-11	CERAMIC CHIP 33PF	5.00% 50V	C3109	1-165-176-11	CERAMIC CHIP 0.047UF	10.00% 16V
C0007	1-107-826-11	CERAMIC CHIP 0.1UF	10.00% 16V	C3110	1-165-176-11	CERAMIC CHIP 0.047UF	10.00% 16V
C0008	1-164-156-11	CERAMIC CHIP 0.1UF	25V	C3121	1-164-156-11	CERAMIC CHIP 0.1UF	25V
C0009	1-162-923-11	CERAMIC CHIP 47PF	5.00% 50V	C3122	1-164-156-11	CERAMIC CHIP 0.1UF	25V
C0011	1-164-156-11	CERAMIC CHIP 0.1UF	25V	C3123	1-164-156-11	CERAMIC CHIP 0.1UF	25V
C0013	1-164-156-11	CERAMIC CHIP 0.1UF	25V	C3124	1-164-156-11	CERAMIC CHIP 0.1UF	25V
C0015	1-164-156-11	CERAMIC CHIP 0.1UF	25V	C3127	1-165-176-11	CERAMIC CHIP 0.047UF	10.00% 16V
C0016	1-164-156-11	CERAMIC CHIP 0.1UF	25V	C3129	1-165-176-11	CERAMIC CHIP 0.047UF	10.00% 16V
C0017	1-164-156-11	CERAMIC CHIP 0.1UF	25V	C3130	1-164-156-11	CERAMIC CHIP 0.1UF	25V
C0018	1-164-156-11	CERAMIC CHIP 0.1UF	25V	C3131	1-164-156-11	CERAMIC CHIP 0.1UF	25V
C0020	1-126-947-11	ELECT 47UF	20.00% 35V	C3132	1-164-156-11	CERAMIC CHIP 0.1UF	25V
C0021	1-164-156-11	CERAMIC CHIP 0.1UF	25V	C3133	1-126-947-11	ELECT 47UF	20.00% 35V
C0023	1-107-715-11	ELECT 22UF	20.00% 50V	C3134	1-164-156-11	CERAMIC CHIP 0.1UF	25V
C0025	1-164-156-11	CERAMIC CHIP 0.1UF	25V	C3135	1-162-919-11	CERAMIC CHIP 22PF	5.00% 50V
C0026	1-126-947-11	ELECT 47UF	20.00% 35V	C3136	1-164-156-11	CERAMIC CHIP 0.1UF	25V
C0028	1-164-156-11	CERAMIC CHIP 0.1UF	25V	C3137	1-162-919-11	CERAMIC CHIP 22PF	5.00% 50V
C0029	1-164-156-11	CERAMIC CHIP 0.1UF	25V	C3138	1-164-156-11	CERAMIC CHIP 0.1UF	25V
C0032	1-164-156-11	CERAMIC CHIP 0.1UF	25V	C3139	1-164-156-11	CERAMIC CHIP 0.1UF	25V
C0033	1-164-156-11	CERAMIC CHIP 0.1UF	25V	C3140	1-164-156-11	CERAMIC CHIP 0.1UF	25V
C0035	1-164-156-11	CERAMIC CHIP 0.1UF	25V	C3141	1-164-156-11	CERAMIC CHIP 0.1UF	25V
C0038	1-164-156-11	CERAMIC CHIP 0.1UF	25V	C3142	1-126-947-11	ELECT 47UF	20.00% 35V
C0039	1-126-947-11	ELECT 47UF	20.00% 35V	C3143	1-126-947-11	ELECT 47UF	20.00% 35V
C0041	1-164-156-11	CERAMIC CHIP 0.1UF	25V	C3144	1-126-947-11	ELECT 47UF	20.00% 35V
C0043	1-164-156-11	CERAMIC CHIP 0.1UF	25V	C3145	1-126-947-11	ELECT 47UF	20.00% 35V
C0045	1-164-156-11	CERAMIC CHIP 0.1UF	25V	C3147	1-164-156-11	CERAMIC CHIP 0.1UF	25V
C0047	1-164-156-11	CERAMIC CHIP 0.1UF	25V	C3148	1-164-156-11	CERAMIC CHIP 0.1UF	25V
C0048	1-164-156-11	CERAMIC CHIP 0.1UF	25V	C3300	1-164-156-11	CERAMIC CHIP 0.1UF	25V
C0051	1-164-156-11	CERAMIC CHIP 0.1UF	25V	C3301	1-164-156-11	CERAMIC CHIP 0.1UF	25V
C0053	1-164-156-11	CERAMIC CHIP 0.1UF	25V	C3302	1-164-156-11	CERAMIC CHIP 0.1UF	25V
C0054	1-126-947-11	ELECT 47UF	20.00% 35V	C3303	1-164-156-11	CERAMIC CHIP 0.1UF	25V
C0055	1-126-947-11	ELECT 47UF	20.00% 35V	C3304	1-164-156-11	CERAMIC CHIP 0.1UF	25V
C0056	1-164-156-11	CERAMIC CHIP 0.1UF	25V	C3305	1-164-156-11	CERAMIC CHIP 0.1UF	25V
C0059	1-164-156-11	CERAMIC CHIP 0.1UF	25V	C3306	1-164-156-11	CERAMIC CHIP 0.1UF	25V
C0060	1-164-230-11	CERAMIC CHIP 220PF	5.00% 50V	C3307	1-126-947-11	ELECT 47UF	20.00% 35V
C0061	1-164-156-11	CERAMIC CHIP 0.1UF	25V	C3308	1-164-156-11	CERAMIC CHIP 0.1UF	25V
C0062	1-126-947-11	ELECT 47UF	20.00% 35V	C3309	1-164-156-11	CERAMIC CHIP 0.1UF	25V
C0063	1-164-230-11	CERAMIC CHIP 220PF	5.00% 50V	C3310	1-164-156-11	CERAMIC CHIP 0.1UF	25V
C0064	1-164-230-11	CERAMIC CHIP 220PF	5.00% 50V	C3311	1-164-156-11	CERAMIC CHIP 0.1UF	25V
C0065	1-164-156-11	CERAMIC CHIP 0.1UF	25V	C3314	1-164-156-11	CERAMIC CHIP 0.1UF	25V
C0066	1-164-156-11	CERAMIC CHIP 0.1UF	25V	C3315	1-164-156-11	CERAMIC CHIP 0.1UF	25V
C3101	1-127-715-91	CERAMIC CHIP 0.22UF	10% 16V	C3316	1-164-156-11	CERAMIC CHIP 0.1UF	25V
C3102	1-127-715-91	CERAMIC CHIP 0.22UF	10% 16V	C3317	1-164-156-11	CERAMIC CHIP 0.1UF	25V
C3103	1-127-715-91	CERAMIC CHIP 0.22UF	10% 16V	C3318	1-164-156-11	CERAMIC CHIP 0.1UF	25V
C3104	1-127-715-91	CERAMIC CHIP 0.22UF	10% 16V	C3319	1-126-947-11	ELECT 47UF	20.00% 35V
C3105	1-127-715-91	CERAMIC CHIP 0.22UF	10% 16V	C3320	1-126-947-11	ELECT 47UF	20.00% 35V
				C3321	1-115-758-11	ELECT 470UF	20.00% 16V
				C3324	1-164-156-11	CERAMIC CHIP 0.1UF	25V

REF.NO.	PART.NO	DESCRIPTION	REMARK	REF.NO.	PART.NO	DESCRIPTION	REMARK
C3402	1-126-947-11	ELECT 47UF	20.00% 35V	C3836	1-164-156-11	CERAMIC CHIP 0.1UF	25V
C3403	1-164-156-11	CERAMIC CHIP 0.1UF	25V	C3837	1-164-156-11	CERAMIC CHIP 0.1UF	25V
C3405	1-164-156-11	CERAMIC CHIP 0.1UF	25V	C3838	1-164-156-11	CERAMIC CHIP 0.1UF	25V
C3406	1-126-947-11	ELECT 47UF	20.00% 35V	C3839	1-164-156-11	CERAMIC CHIP 0.1UF	25V
C3407	1-164-156-11	CERAMIC CHIP 0.1UF	25V	C3840	1-126-947-11	ELECT 47UF	20.00% 35V
C3408	1-126-947-11	ELECT 47UF	20.00% 35V	C3841	1-162-927-11	CERAMIC CHIP 100PF	5.00% 50V
C3409	1-126-947-11	ELECT 47UF	20.00% 35V	C3842	1-162-919-11	CERAMIC CHIP 22UF	5.00% 50V
C3410	1-164-156-11	CERAMIC CHIP 0.1UF	25V	C3844	1-126-947-11	ELECT 47UF	20.00% 35V
C3411	1-164-156-11	CERAMIC CHIP 0.1UF	25V	C3845	1-126-947-11	ELECT 47UF	20.00% 35V
C3413	1-164-156-11	CERAMIC CHIP 0.1UF	25V	C3846	1-126-959-11	ELECT 0.47UF	20.00% 50V
C3431	1-165-176-11	CERAMIC CHIP 0.047UF	10.00% 16V	C3847	1-164-156-11	CERAMIC CHIP 0.1UF	25V
C3432	1-165-176-11	CERAMIC CHIP 0.047UF	10.00% 16V	C3848	1-126-947-11	ELECT 47UF	20.00% 35V
C3433	1-165-176-11	CERAMIC CHIP 0.047UF	10.00% 16V	C3849	1-164-388-91	CERAMIC CHIP 270PF	5.00% 50V
C3436	1-126-947-11	ELECT 47UF	20.00% 35V	C3851	1-126-947-11	ELECT 47UF	20.00% 35V
C3800	1-164-156-11	CERAMIC CHIP 0.1UF	25V	C3853	1-126-960-11	ELECT 1UF	20.00% 50V
C3801	1-126-947-11	ELECT 47UF	20.00% 35V	C3854	1-162-968-11	CERAMIC CHIP 0.0047UF	10.00% 50V
C3802	1-164-156-11	CERAMIC CHIP 0.1UF	25V	C3855	1-162-970-11	CERAMIC CHIP 0.01UF	10.00% 25V
C3803	1-164-156-11	CERAMIC CHIP 0.1UF	25V	C3856	1-126-947-11	ELECT 47UF	20.00% 35V
C3804	1-164-156-11	CERAMIC CHIP 0.1UF	25V	C3857	1-164-156-11	CERAMIC CHIP 0.1UF	25V
C3805	1-164-156-11	CERAMIC CHIP 0.1UF	25V	C3858	1-126-960-11	ELECT 1UF	20.00% 50V
C3806	1-164-156-11	CERAMIC CHIP 0.1UF	25V	C3859	1-126-947-11	ELECT 47UF	20.00% 35V
C3807	1-164-156-11	CERAMIC CHIP 0.1UF	25V	C3861	1-162-927-11	CERAMIC CHIP 100PF	5.00% 50V
C3808	1-164-156-11	CERAMIC CHIP 0.1UF	25V	C3864	1-126-959-11	ELECT 0.47UF	20.00% 50V
C3809	1-126-947-11	ELECT 47UF	20.00% 35V	C3865	1-126-947-11	ELECT 47UF	20.00% 35V
C3810	1-164-156-11	CERAMIC CHIP 0.1UF	25V	C3866	1-164-156-11	CERAMIC CHIP 0.1UF	25V
C3811	1-164-156-11	CERAMIC CHIP 0.1UF	25V	C3867	1-126-963-11	ELECT 4.7UF	20.00% 50V
C3812	1-126-947-11	ELECT 47UF	20.00% 35V	C3868	1-164-156-11	CERAMIC CHIP 0.1UF	25V
C3813	1-126-947-11	ELECT 47UF	20.00% 35V	C3869	1-164-156-11	CERAMIC CHIP 0.1UF	25V
C3814	1-164-156-11	CERAMIC CHIP 0.1UF	25V	C3870	1-164-156-11	CERAMIC CHIP 0.1UF	25V
C3815	1-164-156-11	CERAMIC CHIP 0.1UF	25V	C3871	1-164-315-11	CERAMIC CHIP 470PF	5.00% 50V
C3816	1-164-156-11	CERAMIC CHIP 0.1UF	25V	C3872	1-126-947-11	ELECT 47UF	20.00% 35V
C3817	1-164-156-11	CERAMIC CHIP 0.1UF	25V	C3874	1-164-156-11	CERAMIC CHIP 0.1UF	25V
C3818	1-164-156-11	CERAMIC CHIP 0.1UF	25V	C3875	1-125-891-11	CERAMIC CHIP 0.47UF	10.00% 10V
C3819	1-164-156-11	CERAMIC CHIP 0.1UF	25V	C3876	1-164-156-11	CERAMIC CHIP 0.1UF	25V
C3820	1-164-156-11	CERAMIC CHIP 0.1UF	25V	C3877	1-162-917-11	CERAMIC CHIP 15PF	5.00% 50V
C3821	1-164-156-11	CERAMIC CHIP 0.1UF	25V	C3879	1-126-947-11	ELECT 47UF	20.00% 35V
C3822	1-164-156-11	CERAMIC CHIP 0.1UF	25V	C3882	1-164-156-11	CERAMIC CHIP 0.1UF	25V
C3823	1-164-156-11	CERAMIC CHIP 0.1UF	25V	C3883	1-164-156-11	CERAMIC CHIP 0.1UF	25V
C3824	1-164-156-11	CERAMIC CHIP 0.1UF	25V	C3884	1-164-156-11	CERAMIC CHIP 0.1UF	25V
C3825	1-164-156-11	CERAMIC CHIP 0.1UF	25V	C5503	1-162-927-11	CERAMIC CHIP 100PF	5.00% 50V
C3826	1-164-156-11	CERAMIC CHIP 0.1UF	25V	C5508	1-162-970-11	CERAMIC CHIP 0.01UF	10.00% 25V
C3827	1-164-156-11	CERAMIC CHIP 0.1UF	25V	C5509	1-162-970-11	CERAMIC CHIP 0.01UF	10.00% 25V
C3828	1-164-156-11	CERAMIC CHIP 0.1UF	25V	C5510	1-115-416-11	CERAMIC CHIP 0.001UF	5.00% 25V
C3829	1-164-156-11	CERAMIC CHIP 0.1UF	25V	C5511	1-162-970-11	CERAMIC CHIP 0.01UF	10.00% 25V
C3830	1-164-156-11	CERAMIC CHIP 0.1UF	25V	C5516	1-164-156-11	CERAMIC CHIP 0.1UF	25V
C3831	1-164-156-11	CERAMIC CHIP 0.1UF	25V	C5518	1-164-156-11	CERAMIC CHIP 0.1UF	25V
C3832	1-162-964-11	CERAMIC CHIP 0.001UF	10.00% 50V	C5558	1-126-947-11	ELECT 47UF	20.00% 35V
C3833	1-164-156-11	CERAMIC CHIP 0.1UF	25V				
C3834	1-164-156-11	CERAMIC CHIP 0.1UF	25V				
C3835	1-164-156-11	CERAMIC CHIP 0.1UF	25V				

REF.NO.	PART.NO	DESCRIPTION	REMARK	REF.NO.	PART.NO	DESCRIPTION	REMARK
< CONNECTOR >				L3403	1-414-928-21	INDUCTOR	1UH
CN0004	* 1-564-507-11	PLUG, CONNECTOR 4P		L3404	1-414-928-21	INDUCTOR	1UH
CN3100	1-794-244-11	CONNECTOR, DIN (PLUG) 96P		L3800	1-414-928-21	INDUCTOR	1UH
CN3400	* 1-564-524-11	PLUG, CONNECTOR 9P		L3801	1-414-928-21	INDUCTOR	1UH
CN3401	* 1-764-643-21	PIN, CONNECTOR (SMD) 11P		L3802	1-414-928-21	INDUCTOR	1UH
< DIODE >				L3803	1-414-928-21	INDUCTOR	1UH
D0070	8-719-081-97	DIODE MMDL914T1		L3805	1-414-928-21	INDUCTOR	1UH
D0071	1-216-864-11	SHORT CHIP 0		L3806	1-414-928-21	INDUCTOR	1UH
D5500	8-719-069-55	DIODE UDZSTE-175.6B		L3807	1-414-928-21	INDUCTOR	1UH
D5501	8-719-083-57	DIODE UDZSTE-173.6B		L3808	1-412-987-31	INDUCTOR	4.7UH
D5502	6-500-028-01	DIODE MM3Z9V1ST1		L3809	1-414-928-21	INDUCTOR	1UH
D5504	8-719-081-97	DIODE MMDL914T1		L3810	1-414-928-21	INDUCTOR	1UH
D5505	8-719-081-97	DIODE MMDL914T1		L3856	1-414-928-21	INDUCTOR	1UH
D5506	8-719-081-97	DIODE MMDL914T1		L5549	1-414-928-21	INDUCTOR	1UH
< FILTER >				< TRANSISTOR >			
FL3800	1-233-765-21	FILTER		Q0001	8-729-010-05	TRANSISTOR MSE709-RT1	
FL3801	1-233-765-21	FILTER		Q0002	8-729-010-05	TRANSISTOR MSE709-RT1	
< IC >				Q0003	8-729-010-05	TRANSISTOR MSE709-RT1	
IC0001	6-704-964-01	IC SDA6001-B12T		Q0005	8-729-010-29	TRANSISTOR MSD601-RST1	
IC0002	8-759-682-41	IC M24C32-WMN6T(A)		Q0075	8-729-010-29	TRANSISTOR MSD601-RST1	
IC0003	6-704-312-01	IC K4S641632F-UC75T		Q3409	8-729-010-29	TRANSISTOR MSD601-RST1	
IC0005	6-803-811-01	M27V160-100K1-LE4001		Q3410	8-729-010-29	TRANSISTOR MSD601-RST1	
IC0006	6-702-313-01	PST6001MT		Q3800	8-729-010-29	TRANSISTOR MSD601-RST1	
IC0007	8-759-352-91	IC PST9143NL		Q3801	8-729-010-29	TRANSISTOR MSD601-RST1	
IC3800	6-704-312-01	IC K4S641632F-UC75T		Q3802	8-729-010-29	TRANSISTOR MSD601-RST1	
IC3801	8-752-424-79	IC CXD3804R-T6		Q3803	8-729-010-29	TRANSISTOR MSD601-RST1	
IC3802	8-752-086-80	IC CXA2019AQ-T4		Q3805	8-729-010-29	TRANSISTOR MSD601-RST1	
< COIL >				Q3806	8-729-010-29	TRANSISTOR MSD601-RST1	
L0002	1-414-928-21	INDUCTOR	1UH	Q3807	8-729-010-29	TRANSISTOR MSD601-RST1	
L0003	1-414-928-21	INDUCTOR	1UH	Q3808	8-729-010-29	TRANSISTOR MSD601-RST1	
L0004	1-414-928-21	INDUCTOR	1UH	Q3811	8-729-010-05	TRANSISTOR MSE709-RT1	
L0006	1-414-928-21	INDUCTOR	1UH	Q3812	8-729-010-29	TRANSISTOR MSD601-RST1	
L0007	1-414-928-21	INDUCTOR	1UH	Q3814	8-729-010-29	TRANSISTOR MSD601-RST1	
L0008	1-414-928-21	INDUCTOR	1UH	Q3816	8-729-010-05	TRANSISTOR MSE709-RT1	
L3100	1-414-928-21	INDUCTOR	1UH	Q5500	8-729-010-29	TRANSISTOR MSD601-RST1	
L3104	1-414-928-21	INDUCTOR	1UH	Q5503	8-729-010-29	TRANSISTOR MSD601-RST1	
L3105	1-414-928-21	INDUCTOR	1UH	Q5505	8-729-010-29	TRANSISTOR MSD601-RST1	
L3106	1-414-928-21	INDUCTOR	1UH	Q5507	8-729-010-05	TRANSISTOR MSE709-RT1	
L3107	1-414-928-21	INDUCTOR	1UH	Q5509	8-729-010-29	TRANSISTOR MSD601-RST1	
L3300	1-414-928-21	INDUCTOR	1UH	Q5519	8-729-010-29	TRANSISTOR MSD601-RST1	
L3301	1-414-928-21	INDUCTOR	1UH	Q5550	8-729-010-29	TRANSISTOR MSD601-RST1	
L3302	1-414-928-21	INDUCTOR	1UH	< RESISTOR >			
L3400	1-414-928-21	INDUCTOR	1UH	JR0002	1-216-821-11	METAL CHIP	1K 5% 1/10W
L3401	1-414-928-21	INDUCTOR	1UH	JR0003	1-216-864-11	SHORT CHIP	0
L3402	1-414-928-21	INDUCTOR	1UH	JR0004	1-216-864-11	SHORT CHIP	0
				JR0008	1-216-864-11	SHORT CHIP	0
				JR0010	1-216-864-11	SHORT CHIP	0

REF.NO.	PART.NO	DESCRIPTION	REMARK	REF.NO.	PART.NO	DESCRIPTION	REMARK
JR0011	1-216-864-11	SHORT CHIP	0	R0052	1-216-809-11	METAL CHIP	100 5% 1/10W
JR3400	1-216-864-11	SHORT CHIP	0	R0053	1-216-829-11	METAL CHIP	4.7K 5% 1/10W
JR3404	1-216-864-11	SHORT CHIP	0	R0056	1-216-809-11	METAL CHIP	100 5% 1/10W
JR3406	1-216-864-11	SHORT CHIP	0	R0057	1-216-809-11	METAL CHIP	100 5% 1/10W
JR3408	1-216-864-11	SHORT CHIP	0	R0059	1-216-809-11	METAL CHIP	100 5% 1/10W
JR3409	1-216-864-11	SHORT CHIP	0	R0060	1-216-809-11	METAL CHIP	100 5% 1/10W
R0001	1-216-833-11	METAL CHIP	10K 5% 1/10W	R0063	1-216-809-11	METAL CHIP	100 5% 1/10W
R0002	1-216-833-11	METAL CHIP	10K 5% 1/10W	R0064	1-216-809-11	METAL CHIP	100 5% 1/10W
R0003	1-216-833-11	METAL CHIP	10K 5% 1/10W	R0065	1-216-833-11	METAL CHIP	10K 5% 1/10W
R0004	1-216-816-11	METAL CHIP	390 5% 1/10W	R0066	1-216-833-11	METAL CHIP	10K 5% 1/10W
R0005	1-216-816-11	METAL CHIP	390 5% 1/10W	R0067	1-216-833-11	METAL CHIP	10K 5% 1/10W
R0006	1-216-816-11	METAL CHIP	390 5% 1/10W	R0068	1-216-833-11	METAL CHIP	10K 5% 1/10W
R0007	1-216-817-11	METAL CHIP	470 5% 1/10W	R0069	1-216-833-11	METAL CHIP	10K 5% 1/10W
R0008	1-216-817-11	METAL CHIP	470 5% 1/10W	R0070	1-216-809-11	METAL CHIP	100 5% 1/10W
R0009	1-216-817-11	METAL CHIP	470 5% 1/10W	R0071	1-216-849-11	METAL CHIP	220K 5% 1/10W
R0011	1-216-864-11	SHORT CHIP	0	R0072	1-216-829-11	METAL CHIP	4.7K 5% 1/10W
R0014	1-216-805-11	METAL CHIP	47 5% 1/10W	R0073	1-216-833-11	METAL CHIP	10K 5% 1/10W
R0015	1-216-805-11	METAL CHIP	47 5% 1/10W	R0074	1-216-864-11	SHORT CHIP	0
R0016	1-216-805-11	METAL CHIP	47 5% 1/10W	R0075	1-216-809-11	METAL CHIP	100 5% 1/10W
R0018	1-216-864-11	SHORT CHIP	0	R0076	1-216-864-11	SHORT CHIP	0
R0019	1-216-809-11	METAL CHIP	100 5% 1/10W	R0079	1-216-864-11	SHORT CHIP	0
R0020	1-216-833-11	METAL CHIP	10K 5% 1/10W	R0080	1-216-827-11	METAL CHIP	3.3K 5% 1/10W
R0021	1-216-809-11	METAL CHIP	100 5% 1/10W	R0081	1-216-827-11	METAL CHIP	3.3K 5% 1/10W
R0022	1-216-864-11	SHORT CHIP	0	R0082	1-216-809-11	METAL CHIP	100 5% 1/10W
R0023	1-216-833-11	METAL CHIP	10K 5% 1/10W	R0083	1-216-809-11	METAL CHIP	100 5% 1/10W
R0025	1-216-809-11	METAL CHIP	100 5% 1/10W	R0084	1-216-833-11	METAL CHIP	10K 5% 1/10W
R0026	1-216-809-11	METAL CHIP	100 5% 1/10W	R0085	1-216-829-11	METAL CHIP	4.7K 5% 1/10W
R0027	1-216-809-11	METAL CHIP	100 5% 1/10W	R0086	1-216-809-11	METAL CHIP	100 5% 1/10W
R0028	1-216-833-11	METAL CHIP	10K 5% 1/10W	R0087	1-216-809-11	METAL CHIP	100 5% 1/10W
R0029	1-216-809-11	METAL CHIP	100 5% 1/10W	R0088	1-216-809-11	METAL CHIP	100 5% 1/10W
R0030	1-216-809-11	METAL CHIP	100 5% 1/10W	R0092	1-216-829-11	METAL CHIP	4.7K 5% 1/10W
R0031	1-216-809-11	METAL CHIP	100 5% 1/10W	R0093	1-216-833-11	METAL CHIP	10K 5% 1/10W
R0032	1-216-827-11	METAL CHIP	3.3K 5% 1/10W	R0095	1-216-864-11	SHORT CHIP	0
R0033	1-216-827-11	METAL CHIP	3.3K 5% 1/10W	R0099	1-216-833-11	METAL CHIP	10K 5% 1/10W
R0034	1-216-825-11	METAL CHIP	2.2K 5% 1/10W	R0102	1-216-864-11	SHORT CHIP	0
R0035	1-216-809-11	METAL CHIP	100 5% 1/10W	R0108	1-216-864-11	SHORT CHIP	0
R0036	1-216-809-11	METAL CHIP	100 5% 1/10W	R0137	1-216-833-11	METAL CHIP	10K 5% 1/10W
R0037	1-216-809-11	METAL CHIP	100 5% 1/10W	R3100	1-216-864-11	SHORT CHIP	0
R0038	1-216-825-11	METAL CHIP	2.2K 5% 1/10W	R3101	1-216-864-11	SHORT CHIP	0
R0039	1-216-809-11	METAL CHIP	100 5% 1/10W	R3103	1-216-864-11	SHORT CHIP	0
R0040	1-216-809-11	METAL CHIP	100 5% 1/10W	R3104	1-216-864-11	SHORT CHIP	0
R0042	1-216-809-11	METAL CHIP	100 5% 1/10W	R3106	1-216-864-11	SHORT CHIP	0
R0043	1-216-864-11	SHORT CHIP	0	R3108	1-216-864-11	SHORT CHIP	0
R0044	1-216-809-11	METAL CHIP	100 5% 1/10W	R3109	1-216-809-11	METAL CHIP	100 5% 1/10W
R0045	1-216-809-11	METAL CHIP	100 5% 1/10W	R3110	1-216-809-11	METAL CHIP	100 5% 1/10W
R0046	1-216-833-11	METAL CHIP	10K 5% 1/10W	R3112	1-216-809-11	METAL CHIP	100 5% 1/10W
R0047	1-216-809-11	METAL CHIP	100 5% 1/10W	R3113	1-216-809-11	METAL CHIP	100 5% 1/10W
R0048	1-216-809-11	METAL CHIP	100 5% 1/10W	R3165	1-216-845-11	METAL CHIP	100K 5% 1/10W
R0049	1-216-809-11	METAL CHIP	100 5% 1/10W	R3210	1-216-864-11	SHORT CHIP	0
				R3211	1-216-864-11	SHORT CHIP	0

REF.NO.	PART.NO	DESCRIPTION	REMARK	REF.NO.	PART.NO	DESCRIPTION	REMARK
R3212	1-216-864-11	SHORT CHIP	0	R3820	1-216-864-11	SHORT CHIP	0
R3240	1-216-864-11	SHORT CHIP	0	R3821	1-216-864-11	SHORT CHIP	0
R3241	1-216-864-11	SHORT CHIP	0	R3822	1-216-818-11	METAL CHIP	560 5% 1/10W
R3242	1-216-864-11	SHORT CHIP	0	R3823	1-216-864-11	SHORT CHIP	0
R3270	1-216-864-11	SHORT CHIP	0	R3825	1-216-817-11	METAL CHIP	470 5% 1/10W
R3271	1-216-864-11	SHORT CHIP	0	R3826	1-216-817-11	METAL CHIP	470 5% 1/10W
R3272	1-216-864-11	SHORT CHIP	0	R3829	1-216-817-11	METAL CHIP	470 5% 1/10W
R3300	1-216-809-11	METAL CHIP	100 5% 1/10W	R3830	1-216-841-11	METAL CHIP	47K 5% 1/10W
R3301	1-216-809-11	METAL CHIP	100 5% 1/10W	R3833	1-216-809-11	METAL CHIP	100 5% 1/10W
R3303	1-216-864-11	SHORT CHIP	0	R3834	1-216-841-11	METAL CHIP	47K 5% 1/10W
R3306	1-216-864-11	SHORT CHIP	0	R3836	1-216-817-11	METAL CHIP	470 5% 1/10W
R3307	1-216-864-11	SHORT CHIP	0	R3837	1-216-817-11	METAL CHIP	470 5% 1/10W
R3313	1-216-864-11	SHORT CHIP	0	R3838	1-216-864-11	SHORT CHIP	0
R3401	1-216-821-11	METAL CHIP	1K 5% 1/10W	R3839	1-216-817-11	METAL CHIP	470 5% 1/10W
R3404	1-216-864-11	SHORT CHIP	0	R3840	1-216-864-11	SHORT CHIP	0
R3407	1-216-864-11	SHORT CHIP	0	R3841	1-216-817-11	METAL CHIP	470 5% 1/10W
R3411	1-216-864-11	SHORT CHIP	0	R3845	1-216-801-11	METAL CHIP	22 5% 1/10W
R3413	1-216-864-11	SHORT CHIP	0	R3846	1-216-809-11	METAL CHIP	100 5% 1/10W
R3414	1-216-809-11	METAL CHIP	100 5% 1/10W	R3847	1-216-809-11	METAL CHIP	100 5% 1/10W
R3419	1-216-817-11	METAL CHIP	470 5% 1/10W	R3849	1-216-801-11	METAL CHIP	22 5% 1/10W
R3421	1-216-817-11	METAL CHIP	470 5% 1/10W	R3850	1-218-851-11	METAL CHIP	1.5K 0.5% 1/10W
R3422	1-216-809-11	METAL CHIP	100 5% 1/10W	R3851	1-218-859-11	METAL CHIP	3.3K 0.5% 1/10W
R3423	1-216-817-11	METAL CHIP	470 5% 1/10W	R3852	1-218-831-11	METAL CHIP	220 0.5% 1/10W
R3435	1-216-864-11	SHORT CHIP	0	R3853	1-216-809-11	METAL CHIP	100 5% 1/10W
R3437	1-216-864-11	SHORT CHIP	0	R3854	1-216-821-11	METAL CHIP	1K 5% 1/10W
R3438	1-216-864-11	SHORT CHIP	0	R3855	1-218-839-11	METAL CHIP	470 0.5% 1/10W
R3441	1-216-864-11	SHORT CHIP	0	R3856	1-216-829-11	METAL CHIP	4.7K 5% 1/10W
R3442	1-216-864-11	SHORT CHIP	0	R3857	1-216-827-11	METAL CHIP	3.3K 5% 1/10W
R3443	1-218-847-11	METAL CHIP	1K 0.5% 1/10W	R3859	1-216-821-11	METAL CHIP	1K 5% 1/10W
R3444	1-216-809-11	METAL CHIP	100 5% 1/10W	R3860	1-216-813-11	METAL CHIP	220 5% 1/10W
R3445	1-216-809-11	METAL CHIP	100 5% 1/10W	R3861	1-216-821-11	METAL CHIP	1K 5% 1/10W
R3447	1-216-864-11	SHORT CHIP	0	R3862	1-216-809-11	METAL CHIP	100 5% 1/10W
R3451	1-216-829-11	METAL CHIP	4.7K 5% 1/10W	R3863	1-216-864-11	SHORT CHIP	0
R3452	1-216-817-11	METAL CHIP	470 5% 1/10W	R3864	1-216-809-11	METAL CHIP	100 5% 1/10W
R3800	1-216-864-11	SHORT CHIP	0	R3865	1-216-864-11	SHORT CHIP	0
R3801	1-216-841-11	METAL CHIP	47K 5% 1/10W	R3866	1-216-864-11	SHORT CHIP	0
R3802	1-216-841-11	METAL CHIP	47K 5% 1/10W	R3868	1-216-817-11	METAL CHIP	470 5% 1/10W
R3803	1-216-813-11	METAL CHIP	220 5% 1/10W	R3869	1-216-864-11	SHORT CHIP	0
R3804	1-216-830-11	METAL CHIP	5.6K 5% 1/10W	R3870	1-218-907-11	METAL CHIP	330K 0.5% 1/10W
R3806	1-216-864-11	SHORT CHIP	0	R3871	1-216-825-11	METAL CHIP	2.2K 5% 1/10W
R3807	1-216-818-11	METAL CHIP	560 5% 1/10W	R3874	1-216-819-11	METAL CHIP	680 5% 1/10W
R3808	1-216-864-11	SHORT CHIP	0	R3875	1-216-825-11	METAL CHIP	2.2K 5% 1/10W
R3810	1-216-817-11	METAL CHIP	470 5% 1/10W	R3876	1-218-835-11	METAL CHIP	330 0.5% 1/10W
R3811	1-216-817-11	METAL CHIP	470 5% 1/10W	R3877	1-216-832-11	METAL CHIP	8.2K 5% 1/10W
R3812	1-414-760-21	FERRITE	0UH	R3878	1-216-813-11	METAL CHIP	220 5% 1/10W
R3814	1-216-864-11	SHORT CHIP	0	R3879	1-216-809-11	METAL CHIP	100 5% 1/10W
R3815	1-216-841-11	METAL CHIP	47K 5% 1/10W	R3881	1-216-833-11	METAL CHIP	10K 5% 1/10W
R3816	1-216-830-11	METAL CHIP	5.6K 5% 1/10W	R3882	1-216-809-11	METAL CHIP	100 5% 1/10W
R3817	1-216-841-11	METAL CHIP	47K 5% 1/10W	R3883	1-216-809-11	METAL CHIP	100 5% 1/10W
R3818	1-216-813-11	METAL CHIP	220 5% 1/10W	R3884	1-218-859-11	METAL CHIP	3.3K 0.5% 1/10W

REF.NO.	PART.NO	DESCRIPTION	REMARK			REF.NO.	PART.NO	DESCRIPTION	REMARK		
R3888	1-216-829-11	METAL CHIP	4.7K	5%	1/10W	RB0031	1-233-576-11	RES, CHIP NETWORK	100		
R3890	1-216-864-11	SHORT CHIP	0			RB0032	1-233-576-11	RES, CHIP NETWORK	100		
R3892	1-216-864-11	SHORT CHIP	0			RB0033	1-233-576-11	RES, CHIP NETWORK	100		
R3893	1-216-835-11	METAL CHIP	15K	5%	1/10W	RB0034	1-233-576-11	RES, CHIP NETWORK	100		
R3894	1-216-817-11	METAL CHIP	470	5%	1/10W	RB0035	1-233-576-11	RES, CHIP NETWORK	100		
R5501	1-216-821-11	METAL CHIP	1K	5%	1/10W	RB0036	1-233-576-11	RES, CHIP NETWORK	100		
R5502	1-216-809-11	METAL CHIP	100	5%	1/10W	RB0037	1-233-576-11	RES, CHIP NETWORK	100		
R5504	1-216-809-11	METAL CHIP	100	5%	1/10W	RB0038	1-233-576-11	RES, CHIP NETWORK	100		
R5505	1-216-809-11	METAL CHIP	100	5%	1/10W	RB0039	1-233-576-11	RES, CHIP NETWORK	100		
R5510	1-216-809-11	METAL CHIP	100	5%	1/10W	RB0043	1-233-576-11	RES, CHIP NETWORK	100		
R5511	1-216-809-11	METAL CHIP	100	5%	1/10W	RB0044	1-233-576-11	RES, CHIP NETWORK	100		
R5512	1-216-838-11	METAL CHIP	27K	5%	1/10W	RB0045	1-233-576-11	RES, CHIP NETWORK	100		
R5516	1-218-831-11	METAL CHIP	220	0.5%	1/10W	RB0050	1-233-576-11	RES, CHIP NETWORK	100		
R5517	1-216-809-11	METAL CHIP	100	5%	1/10W	RB0051	1-233-576-11	RES, CHIP NETWORK	100		
R5518	1-216-809-11	METAL CHIP	100	5%	1/10W	RB0052	1-233-576-11	RES, CHIP NETWORK	100		
R5523	1-218-855-11	METAL CHIP	2.2K	0.5%	1/10W	RB0053	1-233-576-11	RES, CHIP NETWORK	100		
R5524	1-216-838-11	METAL CHIP	27K	5%	1/10W	RB0054	1-233-576-11	RES, CHIP NETWORK	100		
R5526	1-216-821-11	METAL CHIP	1K	5%	1/10W	RB0055	1-233-576-11	RES, CHIP NETWORK	100		
R5528	1-216-833-11	METAL CHIP	10K	5%	1/10W	RB3800	1-239-621-11	NETWORK RESISTOR (CHIP)	22		
R5529	1-216-833-11	METAL CHIP	10K	5%	1/10W	RB3801	1-239-621-11	NETWORK RESISTOR (CHIP)	22		
R5532	1-216-821-11	METAL CHIP	1K	5%	1/10W	RB3802	1-239-621-11	NETWORK RESISTOR (CHIP)	22		
R5539	1-218-879-11	METAL CHIP	22K	0.5%	1/10W	RB3803	1-239-621-11	NETWORK RESISTOR (CHIP)	22		
R5540	1-216-838-11	METAL CHIP	27K	5%	1/10W	RB3804	1-239-621-11	NETWORK RESISTOR (CHIP)	22		
R5541	1-216-821-11	METAL CHIP	1K	5%	1/10W	RB3805	1-239-621-11	NETWORK RESISTOR (CHIP)	22		
R5543	1-216-832-11	METAL CHIP	8.2K	5%	1/10W	RB3806	1-239-621-11	NETWORK RESISTOR (CHIP)	22		
R5544	1-216-826-11	METAL CHIP	2.7K	5%	1/10W	RB3807	1-239-621-11	NETWORK RESISTOR (CHIP)	22		
R5545	1-218-895-11	METAL CHIP	100K	0.5%	1/10W	RB3808	1-239-621-11	NETWORK RESISTOR (CHIP)	22		
R5547	1-216-833-11	METAL CHIP	10K	5%	1/10W			< CRYSTAL >			
R5548	1-216-838-11	METAL CHIP	27K	5%	1/10W	X0001	1-567-162-00	OSCILLATOR, CRYSTAL			
R5549	1-216-829-11	METAL CHIP	4.7K	5%	1/10W	X3100	1-781-946-21	VIBRATOR, CRYSTAL			
R5550	1-216-829-11	METAL CHIP	4.7K	5%	1/10W	X3400	1-795-058-21	VIBRATOR, CERAMIC			
R5551	1-216-829-11	METAL CHIP	4.7K	5%	1/10W	X3800	1-767-127-11	VIBRATOR, CERAMIC			
R5552	1-216-829-11	METAL CHIP	4.7K	5%	1/10W	X3801	1-567-504-11	OSCILLATOR, CRYSTAL			
R5555	1-216-829-11	METAL CHIP	4.7K	5%	1/10W						
R5556	1-216-829-11	METAL CHIP	4.7K	5%	1/10W						
R5557	1-216-809-11	METAL CHIP	100	5%	1/10W	* A-1405-803-A A Board, Complete					
R5558	1-216-809-11	METAL CHIP	100	5%	1/10W	4-382-854-01	SCREW (M3X8), P, SW (+)				
R5559	1-216-864-11	SHORT CHIP	0					< CAPACITOR >			
R5560	1-216-833-11	METAL CHIP	10K	5%	1/10W	C0001	1-162-927-11	CERAMIC CHIP 100PF	5.00%	50V	
R5561	1-216-821-11	METAL CHIP	1K	5%	1/10W	C0002	1-162-927-11	CERAMIC CHIP 100PF	5.00%	50V	
R5569	1-216-864-11	SHORT CHIP	0			C1103	1-162-927-11	CERAMIC CHIP 100PF	5.00%	50V	
R5576	1-216-864-11	SHORT CHIP	0			C1104	1-162-927-11	CERAMIC CHIP 100PF	5.00%	50V	
R5577	1-216-864-11	SHORT CHIP	0			C1106	1-164-156-11	CERAMIC CHIP 0.1UF	25V		
R5578	1-216-864-11	SHORT CHIP	0			C1108	1-164-156-11	CERAMIC CHIP 0.1UF	25V		
R5579	1-216-864-11	SHORT CHIP	0			C1109	1-162-921-11	CERAMIC CHIP 33PF	5.00%	50V	
R5580	1-216-864-11	SHORT CHIP	0			C1300	1-162-968-11	CERAMIC CHIP 0.0047UF	10.00%	50V	
		< RESISTOR CHIP >			C1302	1-216-864-11	SHORT CHIP	0			
RB0030	1-233-576-11	RES, CHIP NETWORK	100			C1303	1-162-928-11	CERAMIC CHIP 120PF	5.00%	50V	

REF.NO.	PART.NO	DESCRIPTION	REMARK	REF.NO.	PART.NO	DESCRIPTION	REMARK
C1304	1-216-864-11	SHORT CHIP	0	C2414	1-164-156-11	CERAMIC CHIP	0.1UF 25V
C1307	1-125-891-11	CERAMIC CHIP	0.47UF 10.00% 10V	C2500	1-126-952-11	ELECT	1000UF 20.00% 35V
C1904	1-163-009-91	CERAMIC CHIP	0.001UF 10.00% 50V	C2501	1-126-952-11	ELECT	1000UF 20.00% 35V
C2000	1-126-947-11	ELECT	47UF 20.00% 35V	C2502	1-164-156-11	CERAMIC CHIP	0.1UF 25V
C2001	1-164-156-11	CERAMIC CHIP	0.1UF 25V	C2503	1-164-156-11	CERAMIC CHIP	0.1UF 25V
C2002	1-126-935-11	ELECT	470UF 20.00% 16V	C2504	1-126-964-11	ELECT	10UF 20.00% 50V
C2004	1-164-004-11	CERAMIC CHIP	0.1UF 10.00% 25V	C2505	1-126-947-11	ELECT	47UF 20.00% 35V
C2005	1-127-715-91	CERAMIC CHIP	0.22UF 10% 16V	C2506	1-126-947-11	ELECT	47UF 20.00% 35V
C2006	1-162-964-11	CERAMIC CHIP	0.001UF 10.00% 50V	C2507	1-126-964-11	ELECT	10UF 20.00% 50V
C2007	1-162-966-11	CERAMIC CHIP	0.0022UF 10.00% 50V	C2508	1-126-960-11	ELECT	1UF 20.00% 50V
C2009	1-127-715-91	CERAMIC CHIP	0.22UF 10% 16V	C2511	1-126-947-11	ELECT	47UF 20.00% 35V
C2010	1-127-715-91	CERAMIC CHIP	0.22UF 10% 16V	C2512	1-164-004-11	CERAMIC CHIP	0.1UF 10.00% 25V
C2011	1-162-966-11	CERAMIC CHIP	0.0022UF 10.00% 50V	C2513	1-164-004-11	CERAMIC CHIP	0.1UF 10.00% 25V
C2012	1-162-966-11	CERAMIC CHIP	0.0022UF 10.00% 50V	C2514	1-107-715-11	ELECT	22UF 20.00% 50V
C2013	1-162-966-11	CERAMIC CHIP	0.0022UF 10.00% 50V	C6200	1-164-156-11	CERAMIC CHIP	0.1UF 25V
C2014	1-127-715-91	CERAMIC CHIP	0.22UF 10% 16V	C6201	1-164-156-11	CERAMIC CHIP	0.1UF 25V
C2016	1-162-927-11	CERAMIC CHIP	100PF 5.00% 50V	C6202	1-164-156-11	CERAMIC CHIP	0.1UF 25V
C2017	1-126-964-11	ELECT	10UF 20.00% 50V	C6203	1-164-156-11	CERAMIC CHIP	0.1UF 25V
C2018	1-126-964-11	ELECT	10UF 20.00% 50V	C6204	1-164-156-11	CERAMIC CHIP	0.1UF 25V
C2019	1-126-947-11	ELECT	47UF 20.00% 35V	C6205	1-164-156-11	CERAMIC CHIP	0.1UF 25V
C2020	1-126-947-11	ELECT	47UF 20.00% 35V	C6206	1-104-665-11	ELECT	100UF 20.00% 25V
C2021	1-164-156-11	CERAMIC CHIP	0.1UF 25V	C6207	1-104-665-11	ELECT	100UF 20.00% 25V
C2022	1-126-964-11	ELECT	10UF 20.00% 50V	C6208	1-104-665-11	ELECT	100UF 20.00% 25V
C2023	1-164-156-11	CERAMIC CHIP	0.1UF 25V	C6209	1-104-665-11	ELECT	100UF 20.00% 25V
C2024	1-126-964-11	ELECT	10UF 20.00% 50V	C6210	1-104-665-11	ELECT	100UF 20.00% 25V
C2025	1-162-964-11	CERAMIC CHIP	0.001UF 10.00% 50V	C6211	1-104-665-11	ELECT	100UF 20.00% 25V
C2026	1-164-156-11	CERAMIC CHIP	0.1UF 25V	C6212	1-104-665-11	ELECT	100UF 20.00% 25V
C2027	1-164-156-11	CERAMIC CHIP	0.1UF 25V	C6213	1-164-156-11	CERAMIC CHIP	0.1UF 25V
C2028	1-162-906-11	CERAMIC CHIP	1.5PF 0.25PF 50V	C6214	1-104-665-11	ELECT	100UF 20.00% 25V
C2029	1-162-906-11	CERAMIC CHIP	1.5PF 0.25PF 50V	C6215	1-104-665-11	ELECT	100UF 20.00% 25V
C2030	1-127-715-91	CERAMIC CHIP	0.22UF 10% 16V	C6216	1-126-972-11	ELECT	1000UF 20.00% 50V
C2031	1-127-715-91	CERAMIC CHIP	0.22UF 10% 16V	C6217	1-126-972-11	ELECT	1000UF 20.00% 50V
C2032	1-127-715-91	CERAMIC CHIP	0.22UF 10% 16V	C6218	1-126-972-11	ELECT	1000UF 20.00% 50V
C2033	1-162-964-11	CERAMIC CHIP	0.001UF 10.00% 50V	C6222	1-136-165-00	FILM	0.1UF 5.00% 50V
C2034	1-125-891-11	CERAMIC CHIP	0.47UF 10.00% 10V	C6223	1-136-165-00	FILM	0.1UF 5.00% 50V
C2035	1-125-891-11	CERAMIC CHIP	0.47UF 10.00% 10V	C6225	1-126-767-11	ELECT	1000UF 20.00% 16V
C2040	1-162-927-11	CERAMIC CHIP	100PF 5.00% 50V	C6226	1-126-767-11	ELECT	1000UF 20.00% 16V
C2400	1-136-175-00	FILM	0.68UF 5.00% 50V	C6227	1-126-767-11	ELECT	1000UF 20.00% 16V
C2401	1-165-128-11	CERAMIC CHIP	0.22UF 16V	C6231	1-164-156-11	CERAMIC CHIP	0.1UF 25V
C2402	1-163-135-00	CERAMIC CHIP	560PF 5.00% 50V	C6232	1-164-156-11	CERAMIC CHIP	0.1UF 25V
C2403	1-115-339-11	CERAMIC CHIP	0.1UF 10.00% 50V	C6233	1-126-947-11	ELECT	47UF 20.00% 35V
C2404	1-162-966-11	CERAMIC CHIP	0.0022UF 10.00% 50V	C6234	1-126-947-11	ELECT	47UF 20.00% 35V
C2405	1-162-927-11	CERAMIC CHIP	100PF 5.00% 50V	C6235	1-164-156-11	CERAMIC CHIP	0.1UF 25V
C2406	1-163-021-91	CERAMIC CHIP	0.01UF 10.00% 50V	C6236	1-164-156-11	CERAMIC CHIP	0.1UF 25V
C2407	1-164-505-11	CERAMIC CHIP	2.2UF 16V	C6237	1-104-665-11	ELECT	100UF 20.00% 25V
C2409	1-115-339-11	CERAMIC CHIP	0.1UF 10.00% 50V	C6238	1-104-665-11	ELECT	100UF 20.00% 25V
C2410	1-164-156-11	CERAMIC CHIP	0.1UF 25V	C6239	1-164-156-11	CERAMIC CHIP	0.1UF 25V
C2411	1-164-156-11	CERAMIC CHIP	0.1UF 25V	C6240	1-164-156-11	CERAMIC CHIP	0.1UF 25V
C2412	1-126-943-11	ELECT	2200UF 20.00% 25V	C6241	1-164-156-11	CERAMIC CHIP	0.1UF 25V
C2413	1-126-943-11	ELECT	2200UF 20.00% 25V	C6242	1-104-665-11	ELECT	100UF 20.00% 25V

REF.NO.	PART.NO	DESCRIPTION	REMARK	REF.NO.	PART.NO	DESCRIPTION	REMARK			
C6243	1-104-665-11	ELECT	100UF	20.00%	25V	CN6204	1-695-915-11	TAB (CONTACT)		
C6244	1-126-947-11	ELECT	47UF	20.00%	35V	CN6205	1-695-915-11	TAB (CONTACT)		
C6245	1-126-947-11	ELECT	47UF	20.00%	35V	CN6206	* 1-816-977-51	PLUG, CONNECTOR 6P		
C6247	1-126-964-11	ELECT	10UF	20.00%	50V	CN6207	* 1-564-512-11	PLUG, CONNECTOR 9P		
C6248	1-164-156-11	CERAMIC CHIP	0.1UF		25V	CN6208	* 1-564-512-11	PLUG, CONNECTOR 9P		
C6249	1-104-665-11	ELECT	100UF	20.00%	25V	CN6210	1-764-333-11	PIN, CONNECTOR(PCB) (V TYPE) 10P		
C6250	1-104-665-11	ELECT	100UF	20.00%	25V	CN6900	* 1-816-976-51	PLUG, CONNECTOR 5P		
C6251	1-164-156-11	CERAMIC CHIP	0.1UF		25V					
C6252	1-164-156-11	CERAMIC CHIP	0.1UF		25V					
C6253	1-104-665-11	ELECT	100UF	20.00%	25V				< DIODE >	
C6254	1-104-665-11	ELECT	100UF	20.00%	25V	D0200	8-719-050-37	DIODE M1MA152WA-T1		
C6255	1-164-156-11	CERAMIC CHIP	0.1UF		25V	D1906	8-719-069-55	DIODE UDZSTE-175.6B		
C6256	1-164-156-11	CERAMIC CHIP	0.1UF		25V	D1918	8-719-081-97	DIODE MMDL914T1		
C6257	1-164-156-11	CERAMIC CHIP	0.1UF		25V	D2004	8-719-081-97	DIODE MMDL914T1		
C6258	1-104-665-11	ELECT	100UF	20.00%	25V	D6200	8-719-500-70	DIODE D5S4M		
C6259	1-104-665-11	ELECT	100UF	20.00%	25V	D6201	8-719-500-70	DIODE D5S4M		
C6260	1-164-156-11	CERAMIC CHIP	0.1UF		25V	D6202	8-719-500-70	DIODE D5S4M		
C6262	1-126-933-11	ELECT	100UF	20.00%	16V	D6203	8-719-081-97	DIODE MMDL914T1		
C6263	1-164-156-11	CERAMIC CHIP	0.1UF		25V	D6204	8-719-081-97	DIODE MMDL914T1		
C6264	1-164-156-11	CERAMIC CHIP	0.1UF		25V	D6205	8-719-083-57	DIODE UDZSTE-173.6B		
C6265	1-164-156-11	CERAMIC CHIP	0.1UF		25V	D6206	8-719-081-97	DIODE MMDL914T1		
C6266	1-164-156-11	CERAMIC CHIP	0.1UF		25V	D6207	8-719-081-97	DIODE MMDL914T1		
C6267	1-164-156-11	CERAMIC CHIP	0.1UF		25V	D6208	8-719-081-97	DIODE MMDL914T1		
C6268	1-164-156-11	CERAMIC CHIP	0.1UF		25V	D6209	8-719-081-97	DIODE MMDL914T1		
C6269	1-164-156-11	CERAMIC CHIP	0.1UF		25V	D6210	8-719-050-38	DIODE M1MA152WK-T1		
C6270	1-164-156-11	CERAMIC CHIP	0.1UF		25V	D8481	8-719-050-38	DIODE M1MA152WK-T1		
C8353	1-164-346-11	CERAMIC CHIP	1UF		16V				< FERRITE BEAD >	
C8354	1-164-346-11	CERAMIC CHIP	1UF		16V					
C8355	1-126-935-11	ELECT	470UF	20.00%	16V	FB1101	1-412-987-31	INDUCTOR	4.7UH	
C8356	1-126-382-11	ELECT	100UF	20.00%	16V				< IC >	
C8357	1-126-933-11	ELECT	100UF	20.00%	16V	IC1000	8-752-072-94	IC CXA1875AM-T4		
C8358	1-126-933-11	ELECT	100UF	20.00%	16V	IC2000	6-701-031-11	IC MSP3411G-QA-B11		
C8359	1-126-382-11	ELECT	100UF	20.00%	16V	IC2300	8-759-576-76	IC TDA2822D013TR		
C8360	1-164-004-11	CERAMIC CHIP	0.1UF	10.00%	25V	IC2400	8-759-544-25	IC TDA7482		
C8361	1-164-004-11	CERAMIC CHIP	0.1UF	10.00%	25V	IC2500	8-759-590-05	IC TDA7269A		
< CONNECTOR >										
CN0001	1-764-333-11	PIN, CONNECTOR(PCB) (V TYPE) 10P				IC6200	8-759-648-20	IC L7805CV/LSY		
CN2002	* 1-816-974-51	PLUG, CONNECTOR 3P				IC6201	8-759-445-59	IC BA033T		
CN2003	1-564-507-11	PLUG, CONNECTOR 4P				IC6202	8-759-098-24	IC PQ30RV11		
CN2004	1-564-505-11	PLUG, CONNECTOR 2P				IC6203	8-759-098-24	IC PQ30RV11		
CN2301	* 1-816-976-51	PLUG, CONNECTOR 5P				IC6204	8-759-394-36	IC BA09T		
CN3000	1-764-334-11	PIN, CONNECTOR(PCB) (V TYPE) 11P				IC6205	8-759-098-24	IC PQ30RV11		
CN3001	* 1-816-983-71	PLUG, CONNECTOR 6P				IC6206	8-759-474-09	IC SI-8050S-LF1101		
CN5000	1-817-115-11	CONNECTOR, BOARD TO BOARD, 35P				IC6207	8-759-659-28	IC SI-8033S		
CN5201	* 1-794-243-11	CONNECTOR, DIN (RECEPTACLE) 96P				IC6208	8-759-640-19	IC PQ1CG2032FZ		
CN5209	* 1-564-520-11	PLUG, CONNECTOR 5P				IC6209	8-759-098-24	IC PQ30RV11		
CN6200	* 1-816-985-71	PLUG, CONNECTOR 8P				IC6210	8-759-520-49	IC PQ30RV21		
CN6201	* 1-580-838-11	PIN, CONNECTOR (PC BOARD) 4P				IC6211	8-759-098-24	IC PQ30RV11		
CN6202	* 1-564-510-11	PLUG, CONNECTOR 7P				IC6212	8-759-098-24	IC PQ30RV11		
						IC6213	8-759-098-24	IC PQ30RV11		

Note : The components identified by shading and marked Δ are critical for safety. Replace only with the part numbers specified in the parts list.

A

REF.NO.	PART.NO	DESCRIPTION	REMARK	REF.NO.	PART.NO	DESCRIPTION	REMARK
< SOCKET >				< TRANSISTOR >			
J2200	1-784-632-11	JACK, PIN 2P		Q0200	8-729-028-28	TRANSISTOR 2SK2036 (TE85L)	
< COIL >				Q0201	8-729-028-28	TRANSISTOR 2SK2036 (TE85L)	
L0001	1-412-987-31	INDUCTOR	4.7UH	Q1300	8-729-010-29	TRANSISTOR MSD601-RST1	
L1100	1-414-580-21	INDUCTOR CHIP	100NH	Q1301	8-729-010-05	TRANSISTOR MSB709-RT1	
L1101	1-414-580-21	INDUCTOR CHIP	100NH	Q1912	8-729-120-28	TRANSISTOR 2SC1623-L5L6	
L1102	1-535-303-00	LEAD, JUMPER	(5.0MM)	Q1913	8-729-026-49	TRANSISTOR 2SA1037AK-T146-R	
L1103	1-535-303-00	LEAD, JUMPER	(5.0MM)	Q2001	8-729-010-05	TRANSISTOR MSB709-RT1	
L1104	1-412-979-21	INDUCTOR	1UH	Q2002	8-729-010-29	TRANSISTOR MSD601-RST1	
L1301	1-408-602-31	INDUCTOR	8.2UH	Q2003	8-729-028-28	TRANSISTOR 2SK2036 (TE85L)	
L2000	1-414-928-21	INDUCTOR	1UH	Q2401	8-729-010-29	TRANSISTOR MSD601-RST1	
L2001	1-414-928-21	INDUCTOR	1UH	Q2500	8-729-010-29	TRANSISTOR MSD601-RST1	
L2011	1-414-928-21	INDUCTOR	1UH	Q2501	8-729-010-29	TRANSISTOR MSD601-RST1	
L2221	1-535-303-00	LEAD, JUMPER	(5.0MM)	Q2502	8-729-010-29	TRANSISTOR MSD601-RST1	
L2222	1-535-303-00	LEAD, JUMPER	(5.0MM)	Q2503	8-729-010-29	TRANSISTOR MSD601-RST1	
L2400	1-416-857-11	INDUCTOR	65UH	Q2504	8-729-027-38	TRANSISTOR DTA144EKA-T146	
L2401	1-535-303-00	LEAD, JUMPER	(5.0MM)	Q6201	8-729-900-53	TRANSISTOR DTC114EK	
L2402	1-535-303-00	LEAD, JUMPER	(5.0MM)	Q6202	8-729-900-53	TRANSISTOR DTC114EK	
L2500	1-535-303-00	LEAD, JUMPER	(5.0MM)	Q6203	8-729-900-53	TRANSISTOR DTC114EK	
L2501	1-535-303-00	LEAD, JUMPER	(5.0MM)	Q6204	8-729-010-05	TRANSISTOR MSB709-RT1	
L6200	1-406-662-11	INDUCTOR	33UH	Q6205	8-729-900-53	TRANSISTOR DTC114EK	
L6201	1-406-662-11	INDUCTOR	33UH	Q6206	8-729-010-29	TRANSISTOR MSD601-RST1	
L6202	1-406-662-11	INDUCTOR	33UH	Q6207	8-729-010-29	TRANSISTOR MSD601-RST1	
L6203	1-406-662-11	INDUCTOR	33UH	Q6208	8-729-010-29	TRANSISTOR MSD601-RST1	
L6204	1-406-662-11	INDUCTOR	33UH	Q6209	8-729-120-28	TRANSISTOR 2SC1623-L5L6	
L6205	1-406-662-11	INDUCTOR	33UH	Q8001	8-729-010-29	TRANSISTOR MSD601-RST1	
L6206	1-412-525-31	INDUCTOR	10UH	Q8309	8-729-120-28	TRANSISTOR 2SC1623-L5L6	
L6207	1-412-525-31	INDUCTOR	10UH	Q8311	8-729-120-28	TRANSISTOR 2SC1623-L5L6	
L6208	1-412-525-31	INDUCTOR	10UH	Q8481	8-729-010-05	TRANSISTOR MSB709-RT1	
L6209	1-535-303-00	LEAD, JUMPER	(5.0MM)	< RESISTOR >			
L6210	1-414-928-21	INDUCTOR	1UH	JR8003	1-216-864-11	SHORT CHIP	0
L6211	1-414-928-21	INDUCTOR	1UH	R0002	1-216-864-11	SHORT CHIP	0
L8200	1-535-303-00	LEAD, JUMPER	(5.0MM)	R0200	1-216-829-11	METAL CHIP	4.7K 5% 1/10W
L8201	1-535-303-00	LEAD, JUMPER	(5.0MM)	R0201	1-216-829-11	METAL CHIP	4.7K 5% 1/10W
L8202	1-535-303-00	LEAD, JUMPER	(5.0MM)	R0202	1-216-825-11	METAL CHIP	2.2K 5% 1/10W
L8203	1-535-303-00	LEAD, JUMPER	(5.0MM)	R0204	1-216-833-11	METAL CHIP	10K 5% 1/10W
L8204	1-535-303-00	LEAD, JUMPER	(5.0MM)	R0205	1-216-825-11	METAL CHIP	2.2K 5% 1/10W
L8206	1-535-303-00	LEAD, JUMPER	(5.0MM)	R0207	1-216-833-11	METAL CHIP	10K 5% 1/10W
L8207	1-535-303-00	LEAD, JUMPER	(5.0MM)	R1008	1-216-864-11	SHORT CHIP	0
< PROTECTOR MODULE >				R1101	1-412-987-31	INDUCTOR	4.7UH
PS2000	Δ 1-801-549-21	IC LINK	4A MP250	R1102	1-414-760-21	FERRITE	0UH
PS2001	Δ 1-801-549-21	IC LINK	4A MP250	R1103	1-414-760-21	FERRITE	0UH
PS6201	Δ 1-533-595-31	IC LINK	3.15A 90V	R1105	1-414-580-21	INDUCTOR	100NH
PS6202	Δ 1-533-595-31	IC LINK	3.15A 90V	R1106	1-414-580-21	INDUCTOR	100NH
PS6203	Δ 1-533-595-31	IC LINK	3.15A 90V	R1108	1-414-580-21	INDUCTOR	100NH
				R1109	1-414-580-21	INDUCTOR	100NH
				R1201	1-216-864-11	SHORT CHIP	0

REF.NO.	PART.NO	DESCRIPTION	REMARK			REF.NO.	PART.NO	DESCRIPTION	REMARK		
R1300	1-216-821-11	METAL CHIP	1K	5%	1/10W	R2504	1-216-841-11	METAL CHIP	47K	5%	1/10W
R1303	1-216-805-11	METAL CHIP	47	5%	1/10W	R2505	1-216-821-11	METAL CHIP	1K	5%	1/10W
R1304	1-216-821-11	METAL CHIP	1K	5%	1/10W	R2506	1-216-836-11	METAL CHIP	18K	5%	1/10W
R1956	1-216-833-11	METAL CHIP	10K	5%	1/10W	R2507	1-216-836-11	METAL CHIP	18K	5%	1/10W
R1957	1-216-825-11	METAL CHIP	2.2K	5%	1/10W	R2508	1-216-841-11	METAL CHIP	47K	5%	1/10W
R1958	1-216-825-11	METAL CHIP	2.2K	5%	1/10W	R2509	1-216-831-91	RES CHIP	68K	5%	1/10W
R1959	1-216-825-11	METAL CHIP	2.2K	5%	1/10W	R2511	1-216-837-11	METAL CHIP	22K	5%	1/10W
R1960	1-216-825-11	METAL CHIP	2.2K	5%	1/10W	R2512	1-216-835-11	METAL CHIP	15K	5%	1/10W
R1962	1-216-833-11	METAL CHIP	10K	5%	1/10W	R2513	1-216-825-11	METAL CHIP	2.2K	5%	1/10W
R2000	1-216-864-11	SHORT CHIP	0			R2516	1-216-845-11	METAL CHIP	100K	5%	1/10W
R2001	1-216-864-11	SHORT CHIP	0			R2519	1-216-845-11	METAL CHIP	100K	5%	1/10W
R2002	1-216-833-11	METAL CHIP	10K	5%	1/10W	R2520	1-216-845-11	METAL CHIP	100K	5%	1/10W
R2003	1-216-864-11	SHORT CHIP	0			R2521	1-243-826-21	METAL OXIDE	4.7	5%	1W
R2004	1-216-864-11	SHORT CHIP	0			R2522	1-243-826-21	METAL OXIDE	4.7	5%	1W
R2005	1-216-829-11	METAL CHIP	4.7K	5%	1/10W	R2523	1-216-841-11	METAL CHIP	47K	5%	1/10W
R2006	1-216-829-11	METAL CHIP	4.7K	5%	1/10W	R2524	1-216-864-11	SHORT CHIP	0		
R2007	1-216-829-11	METAL CHIP	4.7K	5%	1/10W	R2525	1-216-821-11	METAL CHIP	1K	5%	1/10W
R2008	1-216-829-11	METAL CHIP	4.7K	5%	1/10W	R6200	1-218-831-11	METAL CHIP	220	0.5%	1/10W
R2009	1-216-841-11	METAL CHIP	47K	5%	1/10W	R6201	1-218-839-11	METAL CHIP	470	0.5%	1/10W
R2010	1-216-864-11	SHORT CHIP	0			R6202	1-216-864-11	SHORT CHIP	0		
R2011	1-216-864-11	SHORT CHIP	0			R6203	1-216-864-11	SHORT CHIP	0		
R2012	1-216-864-11	SHORT CHIP	0			R6204	1-218-831-11	METAL CHIP	220	0.5%	1/10W
R2013	1-216-864-11	SHORT CHIP	0			R6207	1-218-847-11	METAL CHIP	1K	0.5%	1/10W
R2014	1-216-864-11	SHORT CHIP	0			R6208	1-216-864-11	SHORT CHIP	0		
R2015	1-216-864-11	SHORT CHIP	0			R6209	1-216-864-11	SHORT CHIP	0		
R2016	1-216-864-11	SHORT CHIP	0			R6211	1-218-839-11	METAL CHIP	470	0.5%	1/10W
R2017	1-216-809-11	METAL CHIP	100	5%	1/10W	R6212	1-218-839-11	METAL CHIP	470	0.5%	1/10W
R2018	1-216-809-11	METAL CHIP	100	5%	1/10W	R6214	1-216-846-11	METAL CHIP	120K	5%	1/10W
R2019	1-216-825-11	METAL CHIP	2.2K	5%	1/10W	R6215	1-216-844-11	METAL CHIP	82K	5%	1/10W
R2021	1-216-833-11	METAL CHIP	10K	5%	1/10W	R6217	1-216-841-11	METAL CHIP	47K	5%	1/10W
R2022	1-216-845-11	METAL CHIP	100K	5%	1/10W	R6218	1-216-833-11	METAL CHIP	10K	5%	1/10W
R2023	1-216-833-11	METAL CHIP	10K	5%	1/10W	R6221	1-216-834-91	RES CHIP	12K	5%	1/10W
R2024	1-216-841-11	METAL CHIP	47K	5%	1/10W	R6223	1-216-841-11	METAL CHIP	47K	5%	1/10W
R2025	1-216-841-11	METAL CHIP	47K	5%	1/10W	R6224	1-218-867-11	METAL CHIP	6.8K	0.5%	1/10W
R2026	1-216-809-11	METAL CHIP	100	5%	1/10W	R6226	1-218-832-91	RES CHIP	8.2K	5%	1/10W
R2029	1-216-864-11	SHORT CHIP	0			R6228	1-216-812-11	METAL CHIP	180	5%	1/10W
R2030	1-216-864-11	SHORT CHIP	0			R6229	1-216-829-11	METAL CHIP	4.7K	5%	1/10W
R2400	1-218-863-11	METAL CHIP	4.7K	0.5%	1/10W	R6230	1-216-846-11	METAL CHIP	120K	5%	1/10W
R2401	1-216-817-11	METAL CHIP	470	5%	1/10W	R6231	1-216-834-11	METAL CHIP	12K	5%	1/10W
R2402	1-218-827-11	METAL CHIP	150	0.5%	1/10W	R6232	1-216-849-11	METAL CHIP	220K	5%	1/10W
R2403	1-216-833-11	METAL CHIP	10K	5%	1/10W	R6233	1-216-836-11	METAL CHIP	18K	5%	1/10W
R2404	1-218-867-11	METAL CHIP	6.8K	0.5%	1/10W	R6234	1-216-833-11	METAL CHIP	10K	5%	1/10W
R2405	1-216-838-11	METAL CHIP	27K	5%	1/10W	R6235	1-216-839-11	METAL CHIP	33K	5%	1/10W
R2406	1-216-841-11	METAL CHIP	47K	5%	1/10W	R6236	1-216-833-11	METAL CHIP	10K	5%	1/10W
R2407	1-216-833-11	METAL CHIP	10K	5%	1/10W	R6237	1-216-833-11	METAL CHIP	10K	5%	1/10W
R2408	1-218-895-11	METAL CHIP	100K	0.5%	1/10W	R6238	1-216-809-11	METAL CHIP	100	5%	1/10W
R2500	1-216-841-11	METAL CHIP	47K	5%	1/10W	R6239	1-216-821-11	METAL CHIP	1K	5%	1/10W
R2501	1-216-821-11	METAL CHIP	1K	5%	1/10W	R6240	1-216-809-11	METAL CHIP	100	5%	1/10W
R2502	1-216-818-11	METAL CHIP	560	5%	1/10W	R6241	1-216-821-11	METAL CHIP	1K	5%	1/10W
R2503	1-216-818-11	METAL CHIP	560	5%	1/10W	R6242	1-216-821-11	METAL CHIP	1K	5%	1/10W

REF.NO.	PART.NO	DESCRIPTION	REMARK	REF.NO.	PART.NO	DESCRIPTION	REMARK
R6244	1-216-841-11	METAL CHIP	47K 5% 1/10W	R8436	1-216-793-11	METAL CHIP	4.7 5% 1/10W
R6245	1-216-864-11	SHORT CHIP	0	R8437	1-216-793-11	METAL CHIP	4.7 5% 1/10W
R6246	1-216-864-11	SHORT CHIP	0	R8438	1-216-813-11	METAL CHIP	220 5% 1/10W
R6247	1-216-864-11	SHORT CHIP	0	R8439	1-216-813-11	METAL CHIP	220 5% 1/10W
R6251	1-216-809-11	METAL CHIP	100 5% 1/10W	R8481	1-216-821-11	METAL CHIP	1K 5% 1/10W
R6252	1-216-841-11	METAL CHIP	47K 5% 1/10W	R8482	1-216-811-11	METAL CHIP	150 5% 1/10W
R6253	1-216-841-11	METAL CHIP	47K 5% 1/10W	R8483	1-216-811-11	METAL CHIP	150 5% 1/10W
R6254	1-216-829-11	METAL CHIP	4.7K 5% 1/10W	R8484	1-216-811-11	METAL CHIP	150 5% 1/10W
R6256	1-216-841-11	METAL CHIP	47K 5% 1/10W	R8485	1-216-811-11	METAL CHIP	150 5% 1/10W
R6257	1-216-829-11	METAL CHIP	4.7K 5% 1/10W	R8487	1-216-821-11	METAL CHIP	1K 5% 1/10W
R6258	1-216-829-11	METAL CHIP	4.7K 5% 1/10W	< TUNER >			
R6259	1-216-829-11	METAL CHIP	4.7K 5% 1/10W	TU1100	8-598-535-20	FRONTEND BTF-EF411	
R6260	1-216-829-11	METAL CHIP	4.7K 5% 1/10W	< CRYSTAL >			
R6261	1-216-821-11	METAL CHIP	1K 5% 1/10W	X2000	1-760-628-11	VIBRATOR, CRYSTAL	
R6262	1-216-834-11	METAL CHIP	12K 5% 1/10W	* A-1405-804-A J Board, Complete			
R6263	1-216-833-11	METAL CHIP	10K 5% 1/10W	< CAPACITOR >			
R6264	1-216-833-11	METAL CHIP	10K 5% 1/10W	C2804	1-164-227-11	CERAMIC CHIP 0.022UF	10.00% 25V
R6266	1-216-833-11	METAL CHIP	10K 5% 1/10W	C2805	1-162-964-11	CERAMIC CHIP 0.001UF	10.00% 50V
R6267	1-216-833-11	METAL CHIP	10K 5% 1/10W	C2806	1-164-227-11	CERAMIC CHIP 0.022UF	10.00% 25V
R8000	1-216-841-11	METAL CHIP	47K 5% 1/10W	C2807	1-162-964-11	CERAMIC CHIP 0.001UF	10.00% 50V
R8001	1-216-864-11	SHORT CHIP	0	C2808	1-165-908-11	CERAMIC CHIP 1UF	10% 10V
R8002	1-216-809-11	METAL CHIP	100 5% 1/10W	C2809	1-165-908-11	CERAMIC CHIP 1UF	10% 10V
R8003	1-216-809-11	METAL CHIP	100 5% 1/10W	C2810	1-126-947-11	ELECT 47UF	20.00% 35V
R8004	1-216-809-11	METAL CHIP	100 5% 1/10W	C2811	1-126-947-11	ELECT 47UF	20.00% 35V
R8005	1-216-809-11	METAL CHIP	100 5% 1/10W	C2812	1-125-837-91	CERAMIC CHIP 1UF	10% 6.3V
R8006	1-216-809-11	METAL CHIP	100 5% 1/10W	C2813	1-125-837-91	CERAMIC CHIP 1UF	10% 6.3V
R8007	1-216-809-11	METAL CHIP	100 5% 1/10W	C2814	1-164-156-11	CERAMIC CHIP 0.1UF	25V
R8008	1-216-809-11	METAL CHIP	100 5% 1/10W	C2815	1-164-156-11	CERAMIC CHIP 0.1UF	25V
R8009	1-216-809-11	METAL CHIP	100 5% 1/10W	C2821	1-162-964-11	CERAMIC CHIP 0.001UF	10.00% 50V
R8010	1-216-809-11	METAL CHIP	100 5% 1/10W	C2823	1-162-964-11	CERAMIC CHIP 0.001UF	10.00% 50V
R8011	1-216-809-11	METAL CHIP	100 5% 1/10W	C2824	1-165-908-11	CERAMIC CHIP 1UF	10% 10V
R8012	1-216-809-11	METAL CHIP	100 5% 1/10W	C2825	1-165-908-11	CERAMIC CHIP 1UF	10% 10V
R8013	1-216-809-11	METAL CHIP	100 5% 1/10W	C2826	1-126-947-11	ELECT 47UF	20.00% 35V
R8014	1-216-809-11	METAL CHIP	100 5% 1/10W	C2827	1-126-947-11	ELECT 47UF	20.00% 35V
R8015	1-216-809-11	METAL CHIP	100 5% 1/10W	C2832	1-164-227-11	CERAMIC CHIP 0.022UF	10.00% 25V
R8016	1-216-809-11	METAL CHIP	100 5% 1/10W	C2833	1-162-964-11	CERAMIC CHIP 0.001UF	10.00% 50V
R8017	1-216-809-11	METAL CHIP	100 5% 1/10W	C2834	1-164-227-11	CERAMIC CHIP 0.022UF	10.00% 25V
R8018	1-216-864-11	SHORT CHIP	0	C2835	1-162-964-11	CERAMIC CHIP 0.001UF	10.00% 50V
R8019	1-216-864-11	SHORT CHIP	0	C2836	1-165-908-11	CERAMIC CHIP 1UF	10% 10V
R8020	1-216-864-11	SHORT CHIP	0	C2837	1-165-908-11	CERAMIC CHIP 1UF	10% 10V
R8021	1-216-864-11	SHORT CHIP	0	C2838	1-126-947-11	ELECT 47UF	20.00% 35V
R8025	1-216-821-11	METAL CHIP	1K 5% 1/10W	C2839	1-126-947-11	ELECT 47UF	20.00% 35V
R8026	1-216-837-11	METAL CHIP	22K 5% 1/10W	C2855	1-165-908-11	CERAMIC CHIP 1UF	10% 10V
R8201	1-216-864-11	SHORT CHIP	0	C2856	1-165-908-11	CERAMIC CHIP 1UF	10% 10V
R8430	1-216-841-11	METAL CHIP	47K 5% 1/10W	C2857	1-162-923-11	CERAMIC CHIP 47PF	5.00% 50V
R8431	1-216-841-11	METAL CHIP	47K 5% 1/10W	C2858	1-164-156-11	CERAMIC CHIP 0.1UF	25V
R8432	1-216-837-11	METAL CHIP	22K 5% 1/10W				
R8433	1-216-837-11	METAL CHIP	22K 5% 1/10W				
R8434	1-216-825-11	METAL CHIP	2.2K 5% 1/10W				
R8435	1-216-825-11	METAL CHIP	2.2K 5% 1/10W				

REF.NO.	PART.NO	DESCRIPTION	REMARK	REF.NO.	PART.NO	DESCRIPTION	REMARK			
C2859	1-126-964-11	ELECT	10UF	20.00%	50V	< DIODE >				
C2860	1-126-947-11	ELECT	47UF	20.00%	35V	D800	8-719-069-55	DIODE UDZSTE-175.6B		
C3808	1-107-826-11	CERAMIC CHIP	0.1UF	10.00%	16V	D2800	1-803-974-21	VARISTOR CHIP		
C3809	1-107-826-11	CERAMIC CHIP	0.1UF	10.00%	16V	D2801	8-719-069-60	DIODE UDZSTE-179.1B		
C3810	1-126-947-11	ELECT	47UF	20.00%	35V	D2802	1-803-974-21	VARISTOR CHIP		
C3816	1-164-156-11	CERAMIC CHIP	0.1UF		25V	D2803	8-719-069-60	DIODE UDZSTE-179.1B		
C3817	1-107-826-11	CERAMIC CHIP	0.1UF	10.00%	16V	D2804	1-803-974-21	VARISTOR CHIP		
C3818	1-107-826-11	CERAMIC CHIP	0.1UF	10.00%	16V	D2805	8-719-069-60	DIODE UDZSTE-179.1B		
C3819	1-107-826-11	CERAMIC CHIP	0.1UF	10.00%	16V	D2806	1-803-974-21	VARISTOR CHIP		
C3820	1-107-826-11	CERAMIC CHIP	0.1UF	10.00%	16V	D2807	8-719-069-60	DIODE UDZSTE-179.1B		
C3821	1-164-156-11	CERAMIC CHIP	0.1UF		25V	D2808	1-803-974-21	VARISTOR CHIP		
C3822	1-164-156-11	CERAMIC CHIP	0.1UF		25V	D2809	8-719-069-60	DIODE UDZSTE-179.1B		
C3824	1-164-156-11	CERAMIC CHIP	0.1UF		25V	D2810	1-803-974-21	VARISTOR CHIP		
C3825	1-107-826-11	CERAMIC CHIP	0.1UF	10.00%	16V	D2811	8-719-069-60	DIODE UDZSTE-179.1B		
C3826	1-164-156-11	CERAMIC CHIP	0.1UF		25V	D2812	8-719-069-60	DIODE UDZSTE-179.1B		
C3827	1-126-964-11	ELECT	10UF	20.00%	50V	D2813	8-719-069-60	DIODE UDZSTE-179.1B		
C3832	1-164-156-11	CERAMIC CHIP	0.1UF		25V	D2830	8-719-069-60	DIODE UDZSTE-179.1B		
C3834	1-164-156-11	CERAMIC CHIP	0.1UF		25V	D2831	8-719-069-60	DIODE UDZSTE-179.1B		
C3836	1-126-947-11	ELECT	47UF	20.00%	35V	D2832	8-719-069-60	DIODE UDZSTE-179.1B		
C3841	1-164-156-11	CERAMIC CHIP	0.1UF		25V	D2833	8-719-069-60	DIODE UDZSTE-179.1B		
C3842	1-164-156-11	CERAMIC CHIP	0.1UF		25V	D2834	8-719-069-60	DIODE UDZSTE-179.1B		
C3843	1-164-156-11	CERAMIC CHIP	0.1UF		25V	D2835	8-719-069-60	DIODE UDZSTE-179.1B		
C3844	1-164-156-11	CERAMIC CHIP	0.1UF		25V	D3800	8-719-083-63	DIODE UDZSTE-1713B		
C3845	1-126-947-11	ELECT	47UF	20.00%	35V	D3801	8-719-069-55	DIODE UDZSTE-175.6B		
C3846	1-126-947-11	ELECT	47UF	20.00%	35V	D3802	8-719-069-55	DIODE UDZSTE-175.6B		
C3847	1-126-947-11	ELECT	47UF	20.00%	35V	D3803	8-719-069-55	DIODE UDZSTE-175.6B		
C3848	1-126-947-11	ELECT	47UF	20.00%	35V	D3804	8-719-069-55	DIODE UDZSTE-175.6B		
C3849	1-107-826-11	CERAMIC CHIP	0.1UF	10.00%	16V	D3805	8-719-069-55	DIODE UDZSTE-175.6B		
C3857	1-107-826-11	CERAMIC CHIP	0.1UF	10.00%	16V	D3806	8-719-069-55	DIODE UDZSTE-175.6B		
C3858	1-107-826-11	CERAMIC CHIP	0.1UF	10.00%	16V	D3807	8-719-069-55	DIODE UDZSTE-175.6B		
C3860	1-107-826-11	CERAMIC CHIP	0.1UF	10.00%	16V	D3808	8-719-083-63	DIODE UDZSTE-1713B		
C3861	1-107-826-11	CERAMIC CHIP	0.1UF	10.00%	16V	D3809	8-719-069-55	DIODE UDZSTE-175.6B		
C3863	1-162-919-11	CERAMIC CHIP	22PF	5.00%	50V	D3810	8-719-069-55	DIODE UDZSTE-175.6B		
C3864	1-165-908-11	CERAMIC CHIP	1UF	10%	10V	D3811	8-719-069-55	DIODE UDZSTE-175.6B		
C3865	1-165-908-11	CERAMIC CHIP	1UF	10%	10V	D3812	8-719-069-55	DIODE UDZSTE-175.6B		
C3866	1-162-927-11	CERAMIC CHIP	100PF	5.00%	50V	D3813	8-719-069-55	DIODE UDZSTE-175.6B		
C3867	1-162-927-11	CERAMIC CHIP	100PF	5.00%	50V	D3814	8-719-083-63	DIODE UDZSTE-1713B		
C3868	1-162-927-11	CERAMIC CHIP	100PF	5.00%	50V	D3815	8-719-069-55	DIODE UDZSTE-175.6B		
< CONNECTOR >										
CN3800	* 1-564-527-11	PLUG, CONNECTOR	12P					D3816	8-719-069-55	DIODE UDZSTE-175.6B
CN3801	1-695-549-11	SOCKET, PIN	21P					D3817	8-719-069-55	DIODE UDZSTE-175.6B
CN3802	1-695-549-11	SOCKET, PIN	21P					D3818	8-719-069-55	DIODE UDZSTE-175.6B
CN3803	1-695-549-11	SOCKET, PIN	21P					D3819	8-719-069-55	DIODE UDZSTE-175.6B
CN3804	1-817-114-11	CONNECTOR, BOARD TO BOARD	35P					D3820	8-719-069-60	DIODE UDZSTE-179.1B
CN3805	* 1-564-525-11	PLUG, CONNECTOR	10P					D3821	8-719-069-60	DIODE UDZSTE-179.1B
CN3806	* 1-564-523-11	PLUG, CONNECTOR	8P					D3822	8-719-069-55	DIODE UDZSTE-175.6B
CN3807	* 1-564-521-11	PLUG, CONNECTOR	6P					D3823	8-719-069-55	DIODE UDZSTE-175.6B
CN3808	* 1-817-804-11	CONNECTOR, D SUB	15P					D3824	8-719-069-55	DIODE UDZSTE-175.6B
CN3809	* 1-564-525-11	PLUG, CONNECTOR	10P					D3825	8-719-069-55	DIODE UDZSTE-175.6B
								D3826	8-719-069-55	DIODE UDZSTE-175.6B

REF.NO.	PART.NO	DESCRIPTION	REMARK	REF.NO.	PART.NO	DESCRIPTION	REMARK	
D3827	8-719-069-55	DIODE UDZSTE-175.6B		R2806	1-216-813-11	METAL CHIP 220 5%	1/10W	
D3828	8-719-069-55	DIODE UDZSTE-175.6B		R2808	1-216-853-11	METAL CHIP 470K 5%	1/10W	
D3829	8-719-069-55	DIODE UDZSTE-175.6B		R2809	1-216-853-11	METAL CHIP 470K 5%	1/10W	
< FERRITE BEAD >				R2810	1-216-853-11	METAL CHIP 470K 5%	1/10W	
FB001	1-414-813-11	FERRITE	0UH	R2811	1-216-853-11	METAL CHIP 470K 5%	1/10W	
FB3800	1-414-760-21	FERRITE	0UH	R2812	1-216-813-11	METAL CHIP 220 5%	1/10W	
< IC >				R2813	1-216-813-11	METAL CHIP 220 5%	1/10W	
IC3800	8-752-096-83	IC CXA2149AQ-TL		R2817	1-216-821-11	METAL CHIP 1K 5%	1/10W	
IC3801	8-759-661-55	IC ST24FC21M6TR		R2819	1-216-821-11	METAL CHIP 1K 5%	1/10W	
< SOCKET >				R2820	1-216-837-11	METAL CHIP 22K 5%	1/10W	
J2800	1-507-792-00	JACK		R2821	1-216-837-11	METAL CHIP 22K 5%	1/10W	
< COIL >				R2822	1-216-837-11	METAL CHIP 22K 5%	1/10W	
L2802	1-414-928-21	INDUCTOR	1UH	R2823	1-216-837-11	METAL CHIP 22K 5%	1/10W	
L3811	1-414-928-21	INDUCTOR	1UH	R2824	1-216-815-11	METAL CHIP 330 5%	1/10W	
L3812	1-414-928-21	INDUCTOR	1UH	R2825	1-216-049-11	RES-CHIP 1K 5%	1/10W	
L3814	1-414-928-21	INDUCTOR	1UH	R2826	1-216-815-11	METAL CHIP 330 5%	1/10W	
L3816	1-412-975-31	INDUCTOR	0.47UH	R2827	1-216-049-11	RES-CHIP 1K 5%	1/10W	
< TRANSISTOR >				R2828	1-216-813-91	RES CHIP 220 5%	1/10W	
Q2802	8-729-010-29	TRANSISTOR MSD601-RST1		R2830	1-216-813-91	RES CHIP 220 5%	1/10W	
Q2803	8-729-010-29	TRANSISTOR MSD601-RST1		R2832	1-216-853-11	METAL CHIP 470K 5%	1/10W	
Q2804	8-729-010-29	TRANSISTOR MSD601-RST1		R2833	1-216-853-11	METAL CHIP 470K 5%	1/10W	
Q3856	8-729-010-29	TRANSISTOR MSD601-RST1		R2834	1-216-853-11	METAL CHIP 470K 5%	1/10W	
Q3857	8-729-010-29	TRANSISTOR MSD601-RST1		R2835	1-216-853-11	METAL CHIP 470K 5%	1/10W	
Q3858	8-729-010-29	TRANSISTOR MSD601-RST1		R2836	1-216-815-11	METAL CHIP 330 5%	1/10W	
Q3859	8-729-010-05	TRANSISTOR MSB709-RT1		R2837	1-216-049-11	RES-CHIP 1K 5%	1/10W	
Q3860	8-729-010-05	TRANSISTOR MSB709-RT1		R2838	1-216-815-11	METAL CHIP 330 5%	1/10W	
Q3861	8-729-010-05	TRANSISTOR MSB709-RT1		R2839	1-216-049-11	RES-CHIP 1K 5%	1/10W	
Q3862	8-729-010-05	TRANSISTOR MSB709-RT1		R2840	1-216-813-11	METAL CHIP 220 5%	1/10W	
Q3863	8-729-010-29	TRANSISTOR MSD601-RST1		R2842	1-216-813-11	METAL CHIP 220 5%	1/10W	
< RESISTOR >				R2844	1-216-853-11	METAL CHIP 470K 5%	1/10W	
JR2817	1-216-295-91	SHORT CHIP	0	R2845	1-216-853-11	METAL CHIP 470K 5%	1/10W	
JR2818	1-216-295-91	SHORT CHIP	0	R2846	1-216-853-11	METAL CHIP 470K 5%	1/10W	
JR3808	1-216-295-91	SHORT CHIP	0	R2847	1-216-853-11	METAL CHIP 470K 5%	1/10W	
JR3809	1-216-295-91	SHORT CHIP	0	R2848	1-216-821-11	METAL CHIP 1K 5%	1/10W	
JR3810	1-216-295-91	SHORT CHIP	0	R2850	1-216-833-11	METAL CHIP 10K 5%	1/10W	
R802	1-216-025-11	RES-CHIP	100 5%	1/10W	R2851	1-216-864-11	SHORT CHIP 0	
R0800	1-216-809-11	METAL CHIP	100 5%	1/10W	R2852	1-216-864-11	SHORT CHIP 0	
R0801	1-216-809-11	METAL CHIP	100 5%	1/10W	R2853	1-216-864-11	SHORT CHIP 0	
R2800	1-216-815-11	METAL CHIP	330 5%	1/10W	R2854	1-216-864-11	SHORT CHIP 0	
R2801	1-216-049-11	RES-CHIP	1K 5%	1/10W	R2855	1-216-864-11	SHORT CHIP 0	
R2802	1-216-815-11	METAL CHIP	330 5%	1/10W	R2856	1-216-864-11	SHORT CHIP 0	
R2803	1-216-049-11	RES-CHIP	1K 5%	1/10W	R2877	1-216-864-11	SHORT CHIP 0	
R2804	1-216-813-11	METAL CHIP	220 5%	1/10W	R2878	1-216-864-11	SHORT CHIP 0	
					R2879	1-216-864-11	SHORT CHIP 0	
					R2880	1-216-864-11	SHORT CHIP 0	
					R2881	1-216-864-11	SHORT CHIP 0	
					R2882	1-216-864-11	SHORT CHIP 0	
					R3800	1-216-022-00	RES-CHIP 75 5%	1/10W
					R3801	1-216-022-00	RES-CHIP 75 5%	1/10W
					R3802	1-216-022-00	RES-CHIP 75 5%	1/10W

Note : The components identified by shading and marked Δ are critical for safety. Replace only with the part numbers specified in the parts list.



REF.NO.	PART.NO	DESCRIPTION	REMARK	REF.NO.	PART.NO	DESCRIPTION	REMARK
R3803	1-216-022-00	RES-CHIP	75 5% 1/10W	R3872	1-216-813-11	METAL CHIP	220 5% 1/10W
R3804	1-216-022-00	RES-CHIP	75 5% 1/10W	R3873	1-216-821-11	METAL CHIP	1K 5% 1/10W
R3805	1-216-809-11	METAL CHIP	100 5% 1/10W	R3874	1-216-864-11	SHORT CHIP	0
R3807	1-216-809-11	METAL CHIP	100 5% 1/10W	R3875	1-216-805-11	METAL CHIP	47 5% 1/10W
R3808	1-216-809-11	METAL CHIP	100 5% 1/10W	R3876	1-216-805-11	METAL CHIP	47 5% 1/10W
R3809	1-216-809-11	METAL CHIP	100 5% 1/10W	R3877	1-216-812-11	METAL CHIP	180 5% 1/10W
R3810	1-216-809-11	METAL CHIP	100 5% 1/10W	R3879	1-216-807-11	METAL CHIP	68 5% 1/10W
R3811	1-216-022-00	RES-CHIP	75 5% 1/10W	R3880	1-216-808-11	METAL CHIP	82 5% 1/10W
R3812	1-216-809-11	METAL CHIP	100 5% 1/10W	R3881	1-216-812-11	METAL CHIP	180 5% 1/10W
R3813	1-216-022-00	RES-CHIP	75 5% 1/10W	R3883	1-216-807-11	METAL CHIP	68 5% 1/10W
R3814	1-216-809-11	METAL CHIP	100 5% 1/10W	R3884	1-216-808-11	METAL CHIP	82 5% 1/10W
R3815	1-216-022-00	RES-CHIP	75 5% 1/10W	R3885	1-216-812-11	METAL CHIP	180 5% 1/10W
R3816	1-216-022-00	RES-CHIP	75 5% 1/10W	R3887	1-216-807-11	METAL CHIP	68 5% 1/10W
R3817	1-216-022-00	RES-CHIP	75 5% 1/10W	R3888	1-216-808-11	METAL CHIP	82 5% 1/10W
R3818	1-216-022-00	RES-CHIP	75 5% 1/10W	R3889	1-216-864-11	SHORT CHIP	0
R3819	1-216-809-11	METAL CHIP	100 5% 1/10W	R3890	1-216-864-11	SHORT CHIP	0
R3821	1-216-809-11	METAL CHIP	100 5% 1/10W	R3893	1-218-839-11	METAL CHIP	470 0.5% 1/10W
R3822	1-216-809-11	METAL CHIP	100 5% 1/10W	R3894	1-216-864-11	SHORT CHIP	0
R3823	1-216-809-11	METAL CHIP	100 5% 1/10W	R3895	1-216-827-11	METAL CHIP	3.3K 5% 1/10W
R3824	1-216-022-00	RES-CHIP	75 5% 1/10W	R3896	1-216-827-11	METAL CHIP	3.3K 5% 1/10W
R3825	1-216-809-11	METAL CHIP	100 5% 1/10W	< VARISTOR >			
R3826	1-216-022-00	RES-CHIP	75 5% 1/10W	VD2800	1-803-974-21	VARISTOR, CHIP	(1608)
R3827	1-216-022-00	RES-CHIP	75 5% 1/10W	VD2801	1-803-974-21	VARISTOR, CHIP	(1608)
R3828	1-216-022-00	RES-CHIP	75 5% 1/10W	* A-1405-811-A T Board, Complete			
R3829	1-216-022-00	RES-CHIP	75 5% 1/10W	< CONNECTOR >			
R3830	1-216-809-11	METAL CHIP	100 5% 1/10W	CN1000	* 1-564-518-11	PLUG, CONNECTOR 3P	
R3831	1-216-809-11	METAL CHIP	100 5% 1/10W	< SWITCH >			
R3832	1-216-809-11	METAL CHIP	100 5% 1/10W	S1000	1-570-245-11	SWITCH, MICRO	
R3834	1-216-022-00	RES-CHIP	75 5% 1/10W	* A-1302-408-A G Board, Complete			
R3835	1-216-809-11	METAL CHIP	100 5% 1/10W	4-382-854-01	SCREW (M3X8), P, SW (+)		
R3836	1-216-809-11	METAL CHIP	100 5% 1/10W	< CAPACITOR >			
R3838	1-216-864-11	SHORT CHIP	0	C1602	1-163-005-91	CERAMIC CHIP	470PF 10.00% 50V
R3839	1-216-843-11	METAL CHIP	68K 5% 1/10W	C1603	1-107-678-11	ELECT	4.7UF 20.00% 450V
R3841	1-216-843-11	METAL CHIP	68K 5% 1/10W	C1604 Δ	1-161-830-00	CERAMIC	0.0047UF 99% 500V
R3843	1-218-885-11	METAL CHIP	39K 0.5% 1/10W	C1605 Δ	1-161-830-00	CERAMIC	0.0047UF 99% 500V
R3847	1-216-864-11	SHORT CHIP	0	C1606	1-163-809-11	CERAMIC CHIP	0.047UF 10.00% 25V
R3852	1-216-825-11	METAL CHIP	2.2K 5% 1/10W	C1607 Δ	1-161-830-00	CERAMIC	0.0047UF 99% 500V
R3856	1-216-825-11	METAL CHIP	2.2K 5% 1/10W	C1608 Δ	1-161-830-00	CERAMIC	0.0047UF 99% 500V
R3859	1-216-825-11	METAL CHIP	2.2K 5% 1/10W	C1609	1-163-021-91	CERAMIC CHIP	0.01UF 10.00% 50V
R3861	1-216-864-11	SHORT CHIP	0	C1610	1-163-009-91	CERAMIC CHIP	0.001UF 10.00% 50V
R3862	1-216-841-11	METAL CHIP	47K 5% 1/10W	C1612	1-117-753-11	ELECT (BLOCK)	470UF 20.00% 450V
R3863	1-216-841-11	METAL CHIP	47K 5% 1/10W	C1613	1-126-964-11	ELECT	10UF 20.00% 50V
R3864	1-216-841-11	METAL CHIP	47K 5% 1/10W	C1614	1-126-967-11	ELECT	47UF 20.00% 50V
R3865	1-216-837-11	METAL CHIP	22K 5% 1/10W				
R3866	1-216-837-11	METAL CHIP	22K 5% 1/10W				
R3867	1-216-837-11	METAL CHIP	22K 5% 1/10W				
R3868	1-216-835-11	METAL CHIP	15K 5% 1/10W				
R3869	1-216-835-11	METAL CHIP	15K 5% 1/10W				
R3870	1-216-845-11	METAL CHIP	100K 5% 1/10W				
R3871	1-216-805-11	METAL CHIP	47 5% 1/10W				

Note : The components identified by shading and marked Δ are critical for safety. Replace only with the part numbers specified in the parts list.

G

REF.NO.	PART.NO	DESCRIPTION	REMARK	REF.NO.	PART.NO	DESCRIPTION	REMARK
C1615	1-126-948-11	ELECT	100UF 20.00% 35V	C1668	1-109-843-11	CERAMIC 33PF	5.00% 2KV
C1616	1-137-605-11	MYLAR	0.01UF 10.00% 250V	C1669	1-109-843-11	CERAMIC 33PF	5.00% 2KV
C1617	1-126-965-91	ELECT	22UF 20.00% 50V	C1670	1-125-497-11	ELECT (BLOCK) 100UF	20% 400V
C1618	1-136-165-00	FILM	0.1UF 5.00% 50V	C1671	1-125-497-11	ELECT (BLOCK) 100UF	20% 400V
C1620	1-126-960-11	ELECT	1UF 20.00% 50V	C1672	1-161-830-00	CERAMIC 0.0047UF	500V
C1621	1-126-940-11	ELECT	330UF 20.00% 25V	C1674	1-164-004-11	CERAMIC CHIP 0.1UF	10.00% 25V
C1622	1-126-961-11	ELECT	2.2UF 20.00% 50V	C1675	1-163-021-91	CERAMIC CHIP 0.01UF	10.00% 50V
C1623	1-136-479-11	FILM	0.001UF 5.00% 100V	< CONNECTOR >			
C1624	1-126-962-11	ELECT	3.3UF 20.00% 50V	CN1601	Δ * 1-580-843-11	PIN, CONNECTOR (POWER)	
C1625	1-164-004-11	CERAMIC CHIP	0.1UF 10.00% 25V	CN1602	* 1-691-960-11	PIN, CONNECTOR (PC BOARD) 3P	
C1626	1-113-924-11	CERAMIC	0.0047UF 20.00% 250V	CN1603	1-766-281-11	PIN, CONNECTOR (PC BOARD) 8P	
C1627	1-125-969-91	CERAMIC	680PF 10.00% 1KV	CN1604	* 1-580-838-11	PIN, CONNECTOR (PC BOARD) 4P	
C1628	1-125-969-91	CERAMIC	680PF 10.00% 1KV	CN1605	* 1-816-977-51	PLUG, CONNECTOR 6P	
C1629	1-135-946-82	FILM	47000PF 3% 800V	CN1606	* 1-816-978-51	PLUG, CONNECTOR 7P	
C1630	1-126-939-11	ELECT	10000UF 20.00% 16V	CN1607	* 1-564-516-11	PLUG, CONNECTOR 13P	
C1631	1-126-942-61	ELECT	1000UF 20.00% 25V	CN1609	1-695-915-11	TAB (CONTACT)	
C1632	1-126-964-11	ELECT	10UF 20.00% 50V	CN1610	1-695-915-11	TAB (CONTACT)	
C1633	1-126-947-11	ELECT	47UF 20.00% 35V	CN1611	1-695-915-11	TAB (CONTACT)	
C1634	1-128-548-11	ELECT	4700UF 20.00% 25V	CN1612	1-695-915-11	TAB (CONTACT)	
C1635	1-128-548-11	ELECT	4700UF 20.00% 25V	CN1613	* 1-564-512-11	PLUG, CONNECTOR 9P	
C1636	1-163-021-91	CERAMIC CHIP	0.01UF 10.00% 50V	CN1614	* 1-816-974-51	PLUG, CONNECTOR 3P	
C1637	1-126-929-11	ELECT	4700UF 20.00% 10V	CN1615	* 1-564-507-11	PLUG, CONNECTOR 4P	
C1638	1-126-932-51	ELECT	15000UF 20.00% 10V	CN1616	Δ * 1-691-960-11	PIN, CONNECTOR (PC BOARD) 3P	
C1639	1-164-004-11	CERAMIC CHIP	0.1UF 10.00% 25V	< DIODE >			
C1640	1-126-947-11	ELECT	47UF 20.00% 35V	D1601	8-719-077-76	DIODE D2SB60A-F04	
C1641	1-126-947-11	ELECT	47UF 20.00% 35V	D1602	Δ 8-719-022-99	DIODE D6SB60L	
C1642	1-126-964-11	ELECT	10UF 20.00% 50V	D1603	8-719-106-89	DIODE RD15M-T1B2	
C1643	1-126-947-11	ELECT	47UF 20.00% 35V	D1604	8-719-988-61	DIODE 1SS355TE-17	
C1644	1-126-947-11	ELECT	47UF 20.00% 35V	D1605	8-719-948-45	DIODE ERA22-08	
C1645	1-126-947-11	ELECT	47UF 20.00% 35V	D1606	8-719-105-92	DIODE RD5.6M-B3	
C1646	1-163-021-91	CERAMIC CHIP	0.01UF 10.00% 50V	D1607	8-719-979-64	DIODE UF4005PKG23	
C1647	1-163-021-91	CERAMIC CHIP	0.01UF 10.00% 50V	D1608	8-719-060-90	DIODE S2L60F	
C1648	1-163-021-91	CERAMIC CHIP	0.01UF 10.00% 50V	D1609	6-500-175-01	DIODE 1E3-TB	
C1649	1-163-021-91	CERAMIC CHIP	0.01UF 10.00% 50V	D1610	8-719-510-48	DIODE D1N20R	
C1650	1-163-021-91	CERAMIC CHIP	0.01UF 10.00% 50V	D1612	8-719-060-90	DIODE S2L60F	
C1651	1-163-021-91	CERAMIC CHIP	0.01UF 10.00% 50V	D1613	8-719-510-02	DIODE D1NS4	
C1652	1-126-964-11	ELECT	10UF 20.00% 50V	D1614	8-719-510-02	DIODE D1NS4	
C1653	1-126-967-11	ELECT	47UF 20.00% 50V	D1616	8-719-510-02	DIODE D1NS4	
C1654	1-126-947-11	ELECT	47UF 20.00% 35V	D1617	8-719-510-02	DIODE D1NS4	
C1655	1-163-009-91	CERAMIC CHIP	0.001UF 10.00% 50V	D1618	8-719-988-61	DIODE 1SS355TE-17	
C1656	1-163-009-91	CERAMIC CHIP	0.001UF 10.00% 50V	D1619	8-719-105-91	DIODE RD5.6M-B2	
C1657	1-163-009-91	CERAMIC CHIP	0.001UF 10.00% 50V	D1620	8-719-055-40	DIODE FCQ30A04	
C1658	1-163-009-91	CERAMIC CHIP	0.001UF 10.00% 50V	D1621	8-719-018-84	DIODE D2S6M	
C1659	1-137-194-81	FILM	0.47UF 5.00% 50V	D1623	8-719-055-40	DIODE FCQ30A04	
C1660	Δ 1-165-530-11	MYLAR	0.47UF 10 275V	D1624	8-719-510-09	DIODE D10SC6M	
C1661	Δ 1-113-889-11	CERAMIC	0.001UF 20.00% 250V	D1625	8-719-988-31	DIODE D10SC6MR	
C1662	Δ 1-113-889-11	CERAMIC	0.001UF 20.00% 250V	D1626	8-719-510-12	DIODE D10SC4M	
C1664	Δ 1-165-530-11	MYLAR	0.47UF 10 275V	D1629	8-719-988-61	DIODE 1SS355TE-17	
C1666	1-109-843-11	CERAMIC	33PF 5.00% 2KV				
C1667	1-109-843-11	CERAMIC	33PF 5.00% 2KV				

Note : The components identified by shading and marked Δ are critical for safety. Replace only with the part numbers specified in the parts list.

G

REF.NO.	PART.NO	DESCRIPTION	REMARK	REF.NO.	PART.NO	DESCRIPTION	REMARK
D1630	8-719-988-61	DIODE 1SS355TE-17				< TRANSISTOR >	
D1631	8-719-988-61	DIODE 1SS355TE-17					
D1632	1-216-295-91	SHORT CHIP 0		Q1601	8-729-046-40	TRANSISTOR 2SK2663	
D1635	8-719-060-90	DIODE S2L60F		Q1602	8-729-023-22	TRANSISTOR 2SD2114K	
D1636	8-719-060-90	DIODE S2L60F		Q1603	8-729-023-22	TRANSISTOR 2SD2114K	
				Q1604	8-729-216-22	TRANSISTOR 2SA1162-G	
D1638	8-719-988-61	DIODE 1SS355TE-17		Q1605	8-729-023-22	TRANSISTOR 2SD2114K	
D1639	8-719-510-02	DIODE D1NS4					
D1640	8-719-105-91	DIODE RD5.6M-B2		Q1606	8-729-052-32	TRANSISTOR IRFIB7N50A-LF31	
D1641	8-719-988-61	DIODE 1SS355TE-17		Q1607	8-729-052-32	TRANSISTOR IRFIB7N50A-LF31	
D1642	8-719-988-61	DIODE 1SS355TE-17		Q1608	8-729-216-22	TRANSISTOR 2SA1162-G	
		< FUSE >				< RESISTOR >	
F1601	Δ 1-576-232-12	FUSE 5A 250V		R1601	1-260-302-51	CARBON 6.8 5% 1/2W	
FH1601	Δ 1-533-223-11	FUSE HOLDER		R1603	1-216-045-00	RES-CHIP 680 5% 1/10W	
FH1602	Δ 1-533-223-11	FUSE HOLDER		R1604	1-240-205-91	METAL 22M 5% 1/2W	
		< FERRITE BEAD >		R1605	1-216-009-91	RES-CHIP 22 5% 1/10W	
FB1601	1-410-397-21	FERRITE 1.1UH		R1606	1-249-389-11	CARBON 4.7 5% 1/4W	
FB1602	1-410-397-21	FERRITE 1.1UH					
FB1603	1-410-397-21	FERRITE 1.1UH		R1607	1-249-417-11	CARBON 1K 5% 1/4W	
FB1604	1-410-397-21	FERRITE 1.1UH		R1608	1-216-073-91	RES-CHIP 10K 5% 1/10W	
FB1605	1-410-397-21	FERRITE 1.1UH		R1609	1-216-041-00	RES-CHIP 470 5% 1/10W	
		< IC >		R1610	1-216-295-91	SHORT CHIP 0	
IC1601	8-759-670-30	IC MCZ3001D		R1611	1-260-131-11	CARBON 470K 5% 1/2W	
IC1602	8-759-198-31	IC UPC1093J-1-T					
IC1603	8-759-198-31	IC UPC1093J-1-T		R1612	1-215-485-00	METAL 470K 1% 1/4W	
		< COIL >		R1613	Δ 1-202-933-61	FUSIBLE 0.1 10% 1/2W	
L1601	1-412-525-31	INDUCTOR 10UH		R1616	1-249-393-11	CARBON 10 5% 1/4W	
L1602	1-412-523-41	INDUCTOR 6.8UH		R1617	1-249-377-11	CARBON 0.47 5% 1/4W	
L1603	1-412-523-41	INDUCTOR 6.8UH		R1618	1-260-288-11	CARBON 0.47 5% 1/2W	
L1604	1-412-525-31	INDUCTOR 10UH					
L1607	1-412-525-31	INDUCTOR 10UH		R1619	Δ 1-202-933-61	FUSIBLE 0.1 10% 1/2W	
		< PHOTOCOUPLER >		R1620	1-216-073-91	RES-CHIP 10K 5% 1/10W	
PH1601	Δ 6-600-187-01	PHOTO COUPLER PC123Y22J00F		R1621	1-216-065-91	RES-CHIP 4.7K 5% 1/10W	
		< PROTECTOR MODULE >		R1622	1-216-073-91	RES-CHIP 10K 5% 1/10W	
PS1601	Δ 1-576-390-91	IC LINK 2.5A 50V		R1623	1-216-049-11	RES-CHIP 1K 5% 1/10W	
PS1602	Δ 1-576-390-91	IC LINK 2.5A 50V					
				R1624	1-215-481-00	METAL 330K 1% 1/4W	
				R1625	1-215-481-00	METAL 330K 1% 1/4W	
				R1626	1-215-481-00	METAL 330K 1% 1/4W	
				R1627	1-215-859-00	METAL OXIDE 22 5% 1W	
				R1628	1-208-810-11	METAL CHIP 15K 0.5% 1/10W	
				R1629	1-208-806-11	METAL CHIP 10K 0.5% 1/10W	
				R1630	1-216-073-91	RES-CHIP 10K 5% 1/10W	
				R1631	1-216-073-91	RES-CHIP 10K 5% 1/10W	
				R1632	1-249-393-11	CARBON 10 5% 1/4W	
				R1633	1-216-073-91	RES-CHIP 10K 5% 1/10W	
				R1634	1-249-393-11	CARBON 10 5% 1/4W	
				R1635	1-216-073-91	RES-CHIP 10K 5% 1/10W	
				R1638	1-202-965-11	METAL 0.02 10% 2W	
				R1640	1-216-350-11	METAL OXIDE 1.2 5% 1W	
				R1641	1-216-049-11	RES-CHIP 1K 5% 1/10W	
				R1642	1-216-057-00	RES-CHIP 2.2K 5% 1/10W	
				R1643	1-208-790-11	METAL CHIP 2.2K 0.5% 1/10W	
				R1644	1-216-025-11	RES-CHIP 100 5% 1/10W	

Note : The components identified by shading and marked Δ are critical for safety. Replace only with the part numbers specified in the parts list.



REF.NO.	PART.NO	DESCRIPTION	REMARK	REF.NO.	PART.NO	DESCRIPTION	REMARK
R1645	1-216-017-91	RES-CHIP	47 5% 1/10W			< DIODE >	
R1646	1-216-057-00	RES-CHIP	2.2K 5% 1/10W				
R1647	1-216-041-00	RES-CHIP	470 5% 1/10W	D4401	8-719-069-55	DIODE UDZSTE-175.6B	
R1648	1-216-089-91	RES-CHIP	47K 5% 1/10W	D4402	8-719-069-55	DIODE UDZSTE-175.6B	
R1649	1-216-049-11	RES-CHIP	1K 5% 1/10W			< IC >	
R1650	1-208-789-11	METAL CHIP	2K 0.5% 1/10W				
R1651	Δ 1-205-998-11	CEMENTED	1 5% 10W	IC4401	8-742-180-30	HYB IC SBX3081-51(30)	
R1652	Δ 1-205-998-11	CEMENTED	1 5% 10W			< RESISTOR >	
R1653	Δ 1-202-719-00	SOLID	1M 20% 1/2W				
R1654	1-249-377-11	CARBON	0.47 5% 1/4W	R4401	1-216-837-11	METAL CHIP 22K 5% 1/10W	
R1655	1-249-377-11	CARBON	0.47 5% 1/4W	R4402	1-216-805-11	METAL CHIP 47 5% 1/10W	
R1656	1-215-904-11	METAL OXIDE	100K 5% 2W	R4420	1-216-833-11	METAL CHIP 10K 5% 1/10W	
R1657	1-215-904-11	METAL OXIDE	100K 5% 2W	R4421	1-216-829-11	METAL CHIP 4.7K 5% 1/10W	
R1658	1-216-295-91	SHORT CHIP	0	R4422	1-216-864-11	SHORT CHIP 0	
R1660	1-216-295-91	SHORT CHIP	0	R4423	1-216-833-11	METAL CHIP 10K 5% 1/10W	
R1662	Δ 1-218-265-11	METAL	8.2M 5% 1W	R4424	1-216-829-11	METAL CHIP 4.7K 5% 1/10W	
R1664	1-216-295-91	SHORT CHIP	0			< SWITCH >	
R1665	1-208-782-11	METAL CHIP	1K 0.5% 1/10W	S4402	1-572-198-11	SWITCH, KEYBOARD	
R1666	1-208-802-11	METAL CHIP	6.8K 0.5% 1/10W	S4403	1-572-198-11	SWITCH, KEYBOARD	
R1667	1-208-804-11	METAL CHIP	8.2K 0.5% 1/10W	S4404	1-572-198-11	SWITCH, KEYBOARD	
R1668	1-208-807-11	METAL CHIP	11K 0.5% 1/10W	S4405	1-572-198-11	SWITCH, KEYBOARD	
R1669	1-216-041-00	RES-CHIP	470 5% 1/10W	S4406	1-572-198-11	SWITCH, KEYBOARD	
R1670	1-208-806-11	METAL CHIP	10K 0.5% 1/10W				
R1671	1-216-041-00	RES-CHIP	470 5% 1/10W				
		< RELAY >					
RY1601	Δ 1-755-388-11	RELAY (AC POWER)					
		< TRANSFORMER >					
T1601	Δ 1-431-852-11	TRANSFORMER, CONVERTER (SRT)					
T1603	Δ 1-435-512-21	TRANSFORMER, CONVERTER (PIT)					
T1605	Δ 1-433-488-31	TRANSFORMER, LINE FILTER					
		< THERMISTOR >					
TH1601	1-803-586-11	THERMISTOR, NTC					
		< VARISTOR >					
VD1602	Δ 1-804-995-11	VARISTOR					
* A-1405-807-A H1 Board, Complete							
		< CAPACITOR >					
C4402	1-164-156-11	CERAMIC CHIP	0.1UF 25V				
C4403	1-126-382-11	ELECT	100UF 20.00% 16V				
		< CONNECTOR >					
CN4404	* 1-564-520-11	PLUG, CONNECTOR	5P				
		< DIODE >					
D4401	8-719-053-43	DIODE SLR-325VCT31					
D4402	8-719-064-11	DIODE SPR-325MVW					
D4405	8-719-064-11	DIODE SPR-325MVW					
		< TRANSISTOR >					
Q4401	8-729-900-53	TRANSISTOR DTC114EK					
Q4402	8-729-027-23	TRANSISTOR DTA114EKA-T146					
Q4403	8-729-120-28	TRANSISTOR 2SC1623-L5L6					
Q4404	8-729-900-53	TRANSISTOR DTC114EK					
Q4405	8-729-027-23	TRANSISTOR DTA114EKA-T146					
Q4406	8-729-010-29	TRANSISTOR MSD601-RST1					
Q4407	8-729-010-29	TRANSISTOR MSD601-RST1					

*** A-1405-808-A H2 Board, Complete**

< CAPACITOR >

C4403	1-126-601-11	ELECT CHIP	2.2UF	20.00%	50V
C4404	1-124-779-00	ELECT CHIP	10UF	20.00%	16V

< CONNECTOR >

CN4401	* 1-564-522-11	PLUG, CONNECTOR	7P
CN4402	* 1-564-520-11	PLUG, CONNECTOR	5P

< DIODE >

D4401	8-719-053-43	DIODE SLR-325VCT31
D4402	8-719-064-11	DIODE SPR-325MVW
D4405	8-719-064-11	DIODE SPR-325MVW

< TRANSISTOR >

Q4401	8-729-900-53	TRANSISTOR DTC114EK
Q4402	8-729-027-23	TRANSISTOR DTA114EKA-T146
Q4403	8-729-120-28	TRANSISTOR 2SC1623-L5L6
Q4404	8-729-900-53	TRANSISTOR DTC114EK
Q4405	8-729-027-23	TRANSISTOR DTA114EKA-T146
Q4406	8-729-010-29	TRANSISTOR MSD601-RST1
Q4407	8-729-010-29	TRANSISTOR MSD601-RST1

Note : The components identified by shading and marked Δ are critical for safety. Replace only with the part numbers specified in the parts list.



REF.NO.	PART.NO	DESCRIPTION	REMARK	REF.NO.	PART.NO	DESCRIPTION	REMARK
< RESISTOR >				R4303	1-216-813-11	METAL CHIP 220 5%	1/10W
R4402	1-216-809-11	METAL CHIP 100 5%	1/10W	R4305	1-216-821-11	METAL CHIP 1K 5%	1/10W
R4403	1-216-809-11	METAL CHIP 100 5%	1/10W	R4307	1-216-849-11	METAL CHIP 220K 5%	1/10W
R4404	1-216-817-11	METAL CHIP 470 5%	1/10W	R4308	1-216-849-11	METAL CHIP 220K 5%	1/10W
R4405	1-216-817-11	METAL CHIP 470 5%	1/10W	R4309	1-216-813-11	METAL CHIP 220 5%	1/10W
R4406	1-216-845-11	METAL CHIP 100K 5%	1/10W	R4311	1-216-813-11	METAL CHIP 220 5%	1/10W
R4407	1-216-841-11	METAL CHIP 47K 5%	1/10W	R4312	1-216-864-11	SHORT CHIP 0	
R4408	1-216-821-11	METAL CHIP 1K 5%	1/10W	R4313	1-216-864-11	SHORT CHIP 0	
R4409	1-216-805-11	METAL CHIP 47 5%	1/10W	* A-1302-407-A C Board, Complete			
R4410	1-216-833-11	METAL CHIP 10K 5%	1/10W	* 4-096-861-01	SHIELD C LID		
R4411	1-216-821-11	METAL CHIP 1K 5%	1/10W	* 4-096-862-01	BLOCK C RADIATION (S)		
R4412	1-216-805-11	METAL CHIP 47 5%	1/10W	* 4-096-863-01	SHIELD, C (BOT)		
R4415	1-216-864-11	SHORT CHIP 0		* 4-096-864-01	BLOCK C RADIATION (L)		
< SWITCH >				7-621-284-20	SCREW +P 2.6X6		
S4401	Δ 1-554-118-00	SWITCH, PUSH (1 KEY)		< CAPACITOR >			
* A-1405-806-A H3 Board, Complete				C2046	1-164-156-11	CERAMIC CHIP 0.1UF	25V
< CAPACITOR >				C2047	1-164-505-11	CERAMIC CHIP 2.2UF	16V
C4305	1-162-968-11	CERAMIC CHIP 0.0047UF	10.00% 50V	C2048	1-164-156-11	CERAMIC CHIP 0.1UF	25V
C4307	1-162-968-11	CERAMIC CHIP 0.0047UF	10.00% 50V	C2049	1-117-370-11	CERAMIC CHIP 10UF	10V
C4309	1-162-927-11	CERAMIC CHIP 100PF	5.00% 50V	C2050	1-164-505-11	CERAMIC CHIP 2.2UF	16V
< CONNECTOR >				C2052	1-117-370-11	CERAMIC CHIP 10UF	10V
CN4301	* 1-564-521-41	PLUG, CONNECTOR 6P		C2072	1-164-156-11	CERAMIC CHIP 0.1UF	25V
CN4302	* 1-564-520-11	PLUG, CONNECTOR 5P		C2079	1-164-156-11	CERAMIC CHIP 0.1UF	25V
CN4303	* 1-564-524-11	PLUG, CONNECTOR 9P		C2087	1-164-156-11	CERAMIC CHIP 0.1UF	25V
< DIODE >				C2088	1-164-156-11	CERAMIC CHIP 0.1UF	25V
D4301	8-719-016-73	DIODE ST26.8T		C2501	1-164-156-11	CERAMIC CHIP 0.1UF	25V
D4302	8-719-016-73	DIODE ST26.8T		C2502	1-117-370-11	CERAMIC CHIP 10UF	10V
D4303	8-719-016-73	DIODE ST26.8T		C2503	1-164-156-11	CERAMIC CHIP 0.1UF	25V
D4304	8-719-016-73	DIODE ST26.8T		C2504	1-164-156-11	CERAMIC CHIP 0.1UF	25V
D4305	8-719-016-73	DIODE ST26.8T		C2506	1-164-505-11	CERAMIC CHIP 2.2UF	16V
D4306	8-719-016-73	DIODE ST26.8T		C2507	1-164-156-11	CERAMIC CHIP 0.1UF	25V
< SOCKET >				C2509	1-117-370-11	CERAMIC CHIP 10UF	10V
J4301	1-779-947-11	TERMINAL BLOCK, S		C2510	1-164-156-11	CERAMIC CHIP 0.1UF	25V
J4302	1-785-448-11	JACK		C2512	1-164-156-11	CERAMIC CHIP 0.1UF	25V
< COIL >				C2513	1-164-156-11	CERAMIC CHIP 0.1UF	25V
L4301	1-414-189-31	INDUCTOR 100UH		C2514	1-164-156-11	CERAMIC CHIP 0.1UF	25V
L4302	1-414-189-31	INDUCTOR 100UH		C2515	1-128-992-21	ELECT CHIP 47UF	20% 25V
L4303	1-410-985-42	INDUCTOR 0.22UH		C2516	1-128-992-21	ELECT CHIP 47UF	20% 25V
< RESISTOR >				C2517	1-164-156-11	CERAMIC CHIP 0.1UF	25V
R4301	1-216-813-11	METAL CHIP 220 5%	1/10W	C2518	1-164-505-11	CERAMIC CHIP 2.2UF	16V
				C2519	1-164-505-11	CERAMIC CHIP 2.2UF	16V
				C2520	1-128-992-21	ELECT CHIP 47UF	20% 25V
				C2521	1-164-156-11	CERAMIC CHIP 0.1UF	25V
				C2522	1-164-156-11	CERAMIC CHIP 0.1UF	25V
				C2523	1-164-156-11	CERAMIC CHIP 0.1UF	25V
				C2524	1-164-156-11	CERAMIC CHIP 0.1UF	25V
				C2527	1-128-992-21	ELECT CHIP 47UF	20% 25V

REF.NO.	PART.NO	DESCRIPTION	REMARK	REF.NO.	PART.NO	DESCRIPTION	REMARK
C2529	1-164-156-11	CERAMIC CHIP 0.1UF	25V	C2663	1-164-156-11	CERAMIC CHIP 0.1UF	25V
C2530	1-164-156-11	CERAMIC CHIP 0.1UF	25V	C2664	1-164-156-11	CERAMIC CHIP 0.1UF	25V
C2531	1-164-156-11	CERAMIC CHIP 0.1UF	25V	C2665	1-164-156-11	CERAMIC CHIP 0.1UF	25V
C2551	1-164-156-11	CERAMIC CHIP 0.1UF	25V	C2666	1-128-992-21	ELECT CHIP 47UF	20% 25V
C2552	1-164-156-11	CERAMIC CHIP 0.1UF	25V	C2701	1-164-156-11	CERAMIC CHIP 0.1UF	25V
C2553	1-128-992-21	ELECT CHIP 47UF	20% 25V	C2702	1-117-370-11	CERAMIC CHIP 10UF	10V
C2554	1-164-156-11	CERAMIC CHIP 0.1UF	25V	C2703	1-164-156-11	CERAMIC CHIP 0.1UF	25V
C2555	1-164-156-11	CERAMIC CHIP 0.1UF	25V	C2704	1-164-156-11	CERAMIC CHIP 0.1UF	25V
C2556	1-164-156-11	CERAMIC CHIP 0.1UF	25V	C2706	1-164-505-11	CERAMIC CHIP 2.2UF	16V
C2557	1-128-992-21	ELECT CHIP 47UF	20% 25V	C2707	1-164-156-11	CERAMIC CHIP 0.1UF	25V
C2558	1-164-156-11	CERAMIC CHIP 0.1UF	25V	C2709	1-117-370-11	CERAMIC CHIP 10UF	10V
C2601	1-164-156-11	CERAMIC CHIP 0.1UF	25V	C2710	1-164-156-11	CERAMIC CHIP 0.1UF	25V
C2602	1-117-370-11	CERAMIC CHIP 10UF	10V	C2712	1-164-156-11	CERAMIC CHIP 0.1UF	25V
C2603	1-164-156-11	CERAMIC CHIP 0.1UF	25V	C2713	1-164-156-11	CERAMIC CHIP 0.1UF	25V
C2604	1-164-156-11	CERAMIC CHIP 0.1UF	25V	C2715	1-164-156-11	CERAMIC CHIP 0.1UF	25V
C2606	1-164-505-11	CERAMIC CHIP 2.2UF	16V	C2716	1-126-396-11	ELECT CHIP 47UF	20.00% 16V
C2607	1-164-156-11	CERAMIC CHIP 0.1UF	25V	C2717	1-164-156-11	CERAMIC CHIP 0.1UF	25V
C2609	1-117-370-11	CERAMIC CHIP 10UF	10V	C2718	1-164-505-11	CERAMIC CHIP 2.2UF	16V
C2610	1-164-156-11	CERAMIC CHIP 0.1UF	25V	C2719	1-164-505-11	CERAMIC CHIP 2.2UF	16V
C2612	1-164-156-11	CERAMIC CHIP 0.1UF	25V	C2720	1-126-396-11	ELECT CHIP 47UF	20.00% 16V
C2613	1-164-156-11	CERAMIC CHIP 0.1UF	25V	C2721	1-164-156-11	CERAMIC CHIP 0.1UF	25V
C2615	1-164-156-11	CERAMIC CHIP 0.1UF	25V	C2722	1-164-156-11	CERAMIC CHIP 0.1UF	25V
C2616	1-126-396-11	ELECT CHIP 47UF	20.00% 16V	C2723	1-164-156-11	CERAMIC CHIP 0.1UF	25V
C2617	1-164-156-11	CERAMIC CHIP 0.1UF	25V	C2724	1-164-156-11	CERAMIC CHIP 0.1UF	25V
C2618	1-164-505-11	CERAMIC CHIP 2.2UF	16V	C2725	1-164-156-11	CERAMIC CHIP 0.1UF	25V
C2619	1-164-505-11	CERAMIC CHIP 2.2UF	16V	C2727	1-126-396-11	ELECT CHIP 47UF	20.00% 16V
C2620	1-126-204-11	ELECT CHIP 47UF	20.00% 16V	C2729	1-164-156-11	CERAMIC CHIP 0.1UF	25V
C2621	1-164-156-11	CERAMIC CHIP 0.1UF	25V	C2801	1-164-156-11	CERAMIC CHIP 0.1UF	25V
C2622	1-164-156-11	CERAMIC CHIP 0.1UF	25V	C2802	1-128-992-21	ELECT CHIP 47UF	20% 25V
C2623	1-164-156-11	CERAMIC CHIP 0.1UF	25V	C3011	1-117-681-11	ELECT CHIP 100UF	20.00% 16V
C2624	1-164-156-11	CERAMIC CHIP 0.1UF	25V	C3012	1-117-681-11	ELECT CHIP 100UF	20.00% 16V
C2625	1-164-156-11	CERAMIC CHIP 0.1UF	25V	C3013	1-117-681-11	ELECT CHIP 100UF	20.00% 16V
C2626	1-164-156-11	CERAMIC CHIP 0.1UF	25V	C3014	1-117-681-11	ELECT CHIP 100UF	20.00% 16V
C2627	1-126-396-11	ELECT CHIP 47UF	20.00% 16V	C3015	1-117-681-11	ELECT CHIP 100UF	20.00% 16V
C2628	1-128-992-21	ELECT CHIP 47UF	20% 25V	C3016	1-117-681-11	ELECT CHIP 100UF	20.00% 16V
C2629	1-164-156-11	CERAMIC CHIP 0.1UF	25V	C3017	1-117-681-11	ELECT CHIP 100UF	20.00% 16V
C2630	1-164-156-11	CERAMIC CHIP 0.1UF	25V	C3018	1-126-204-11	ELECT CHIP 47UF	20.00% 16V
C2631	1-128-992-21	ELECT CHIP 47UF	20% 25V	C3019	1-164-156-11	CERAMIC CHIP 0.1UF	25V
C2632	1-164-156-11	CERAMIC CHIP 0.1UF	25V	C3020	1-164-156-11	CERAMIC CHIP 0.1UF	25V
C2651	1-164-156-11	CERAMIC CHIP 0.1UF	25V	C3021	1-164-156-11	CERAMIC CHIP 0.1UF	25V
C2652	1-164-156-11	CERAMIC CHIP 0.1UF	25V	C3022	1-164-156-11	CERAMIC CHIP 0.1UF	25V
C2653	1-128-992-21	ELECT CHIP 47UF	20% 25V	C3023	1-164-156-11	CERAMIC CHIP 0.1UF	25V
C2654	1-164-156-11	CERAMIC CHIP 0.1UF	25V	C3024	1-164-156-11	CERAMIC CHIP 0.1UF	25V
C2655	1-164-156-11	CERAMIC CHIP 0.1UF	25V	C3025	1-164-156-11	CERAMIC CHIP 0.1UF	25V
C2656	1-164-156-11	CERAMIC CHIP 0.1UF	25V	C3026	1-164-156-11	CERAMIC CHIP 0.1UF	25V
C2657	1-164-156-11	CERAMIC CHIP 0.1UF	25V	C3027	1-164-156-11	CERAMIC CHIP 0.1UF	25V
C2658	1-128-992-21	ELECT CHIP 47UF	20% 25V	C3028	1-164-156-11	CERAMIC CHIP 0.1UF	25V
C2659	1-164-156-11	CERAMIC CHIP 0.1UF	25V	C3029	1-164-156-11	CERAMIC CHIP 0.1UF	25V
C2661	1-128-992-21	ELECT CHIP 47UF	20% 25V	C3030	1-164-156-11	CERAMIC CHIP 0.1UF	25V
C2662	1-164-156-11	CERAMIC CHIP 0.1UF	25V	C3031	1-164-156-11	CERAMIC CHIP 0.1UF	25V

REF.NO.	PART.NO	DESCRIPTION	REMARK	REF.NO.	PART.NO	DESCRIPTION	REMARK
C3032	1-164-156-11	CERAMIC CHIP 0.1UF	25V	C3106	1-162-970-11	CERAMIC CHIP 0.01UF	10.00% 25V
C3033	1-164-156-11	CERAMIC CHIP 0.1UF	25V	C3107	1-162-970-11	CERAMIC CHIP 0.01UF	10.00% 25V
C3034	1-164-156-11	CERAMIC CHIP 0.1UF	25V	C3108	1-126-204-11	ELECT CHIP 47UF	20.00% 16V
C3035	1-117-681-11	ELECT CHIP 100UF	20.00% 16V	C3109	1-126-204-11	ELECT CHIP 47UF	20.00% 16V
C3036	1-117-681-11	ELECT CHIP 100UF	20.00% 16V	C3110	1-162-970-11	CERAMIC CHIP 0.01UF	10.00% 25V
C3037	1-117-681-11	ELECT CHIP 100UF	20.00% 16V	C3111	1-162-970-11	CERAMIC CHIP 0.01UF	10.00% 25V
C3038	1-117-681-11	ELECT CHIP 100UF	20.00% 16V	C3112	1-162-970-11	CERAMIC CHIP 0.01UF	10.00% 25V
C3054	1-117-681-11	ELECT CHIP 100UF	20.00% 16V	C3113	1-162-970-11	CERAMIC CHIP 0.01UF	10.00% 25V
C3055	1-117-681-11	ELECT CHIP 100UF	20.00% 16V	C3114	1-162-970-11	CERAMIC CHIP 0.01UF	10.00% 25V
C3056	1-117-681-11	ELECT CHIP 100UF	20.00% 16V	C3115	1-162-970-11	CERAMIC CHIP 0.01UF	10.00% 25V
C3057	1-126-204-11	ELECT CHIP 47UF	20.00% 16V	C3116	1-162-970-11	CERAMIC CHIP 0.01UF	10.00% 25V
C3061	1-162-927-11	CERAMIC CHIP 100PF	5.00% 50V	C3117	1-162-970-11	CERAMIC CHIP 0.01UF	10.00% 25V
C3062	1-162-927-11	CERAMIC CHIP 100PF	5.00% 50V	C3118	1-162-970-11	CERAMIC CHIP 0.01UF	10.00% 25V
C3063	1-126-601-11	ELECT CHIP 2.2UF	20.00% 50V	C3119	1-162-970-11	CERAMIC CHIP 0.01UF	10.00% 25V
C3064	1-126-601-11	ELECT CHIP 2.2UF	20.00% 50V	C3120	1-162-970-11	CERAMIC CHIP 0.01UF	10.00% 25V
C3065	1-126-601-11	ELECT CHIP 2.2UF	20.00% 50V	C3121	1-162-970-11	CERAMIC CHIP 0.01UF	10.00% 25V
C3072	1-164-156-11	CERAMIC CHIP 0.1UF	25V	C3122	1-162-970-11	CERAMIC CHIP 0.01UF	10.00% 25V
C3073	1-164-156-11	CERAMIC CHIP 0.1UF	25V	C3123	1-162-970-11	CERAMIC CHIP 0.01UF	10.00% 25V
C3074	1-164-156-11	CERAMIC CHIP 0.1UF	25V	C3124	1-162-970-11	CERAMIC CHIP 0.01UF	10.00% 25V
C3075	1-126-210-21	CAP ELECT 220UF	20.00% 4V	C3125	1-162-970-11	CERAMIC CHIP 0.01UF	10.00% 25V
C3076	1-115-156-11	CERAMIC CHIP 1UF	10V	C3126	1-162-970-11	CERAMIC CHIP 0.01UF	10.00% 25V
C3077	1-162-964-11	CERAMIC CHIP 0.001UF	10.00% 50V	C3127	1-162-970-11	CERAMIC CHIP 0.01UF	10.00% 25V
C3078	1-162-964-11	CERAMIC CHIP 0.001UF	10.00% 50V	C3128	1-162-970-11	CERAMIC CHIP 0.01UF	10.00% 25V
C3079	1-162-964-11	CERAMIC CHIP 0.001UF	10.00% 50V	C3129	1-162-970-11	CERAMIC CHIP 0.01UF	10.00% 25V
C3080	1-162-964-11	CERAMIC CHIP 0.001UF	10.00% 50V	C3130	1-162-970-11	CERAMIC CHIP 0.01UF	10.00% 25V
C3081	1-162-964-11	CERAMIC CHIP 0.001UF	10.00% 50V	C3131	1-162-970-11	CERAMIC CHIP 0.01UF	10.00% 25V
C3082	1-162-964-11	CERAMIC CHIP 0.001UF	10.00% 50V	C3133	1-162-964-11	CERAMIC CHIP 0.001UF	10.00% 50V
C3083	1-162-964-11	CERAMIC CHIP 0.001UF	10.00% 50V	C3134	1-162-964-11	CERAMIC CHIP 0.001UF	10.00% 50V
C3084	1-162-964-11	CERAMIC CHIP 0.001UF	10.00% 50V	C3135	1-124-779-00	ELECT CHIP 10UF	20.00% 16V
C3085	1-162-919-11	CERAMIC CHIP 22PF	5.00% 50V	C3136	1-162-964-11	CERAMIC CHIP 0.001UF	10.00% 50V
C3086	1-162-919-11	CERAMIC CHIP 22PF	5.00% 50V	C3138	1-126-601-11	ELECT CHIP 2.2UF	20.00% 50V
C3087	1-162-964-11	CERAMIC CHIP 0.001UF	10.00% 50V	C3139	1-126-601-11	ELECT CHIP 2.2UF	20.00% 50V
C3088	1-162-964-11	CERAMIC CHIP 0.001UF	10.00% 50V	C3140	1-126-601-11	ELECT CHIP 2.2UF	20.00% 50V
C3089	1-162-964-11	CERAMIC CHIP 0.001UF	10.00% 50V	C3141	1-162-964-11	CERAMIC CHIP 0.001UF	10.00% 50V
C3090	1-162-964-11	CERAMIC CHIP 0.001UF	10.00% 50V	C3142	1-126-603-11	ELECT CHIP 4.7UF	20.00% 35V
C3091	1-162-964-11	CERAMIC CHIP 0.001UF	10.00% 50V	C3143	1-162-970-11	CERAMIC CHIP 0.01UF	10.00% 25V
C3092	1-162-964-11	CERAMIC CHIP 0.001UF	10.00% 50V	C3144	1-126-204-11	ELECT CHIP 47UF	20.00% 16V
C3093	1-124-779-00	ELECT CHIP 10UF	20.00% 16V	C3145	1-107-826-11	CERAMIC CHIP 0.1UF	10.00% 16V
C3094	1-162-964-11	CERAMIC CHIP 0.001UF	10.00% 50V	C4000	1-128-992-21	ELECT CHIP 47UF	20% 25V
C3095	1-162-964-11	CERAMIC CHIP 0.001UF	10.00% 50V	C4001	1-162-919-11	CERAMIC CHIP 22PF	5.00% 50V
C3096	1-124-779-00	ELECT CHIP 10UF	20.00% 16V	C4002	1-162-919-11	CERAMIC CHIP 22PF	5.00% 50V
C3097	1-162-964-11	CERAMIC CHIP 0.001UF	10.00% 50V	C4003	1-164-156-11	CERAMIC CHIP 0.1UF	25V
C3098	1-124-779-00	ELECT CHIP 10UF	20.00% 16V	C4004	1-164-156-11	CERAMIC CHIP 0.1UF	25V
C3099	1-162-964-11	CERAMIC CHIP 0.001UF	10.00% 50V	C4005	1-164-156-11	CERAMIC CHIP 0.1UF	25V
C3100	1-162-964-11	CERAMIC CHIP 0.001UF	10.00% 50V	C4006	1-164-156-11	CERAMIC CHIP 0.1UF	25V
C3101	1-164-156-11	CERAMIC CHIP 0.1UF	25V	C4007	1-164-156-11	CERAMIC CHIP 0.1UF	25V
C3102	1-115-156-11	CERAMIC CHIP 1UF	10V	C4008	1-164-156-11	CERAMIC CHIP 0.1UF	25V
C3103	1-164-156-11	CERAMIC CHIP 0.1UF	25V	C4009	1-164-156-11	CERAMIC CHIP 0.1UF	25V
C3104	1-124-779-00	ELECT CHIP 10UF	20.00% 16V	C4010	1-164-156-11	CERAMIC CHIP 0.1UF	25V
C3105	1-164-156-11	CERAMIC CHIP 0.1UF	25V	C4011	1-164-156-11	CERAMIC CHIP 0.1UF	25V



REF.NO.	PART.NO	DESCRIPTION	REMARK	REF.NO.	PART.NO	DESCRIPTION	REMARK
C4012	1-127-715-91	CERAMIC CHIP 0.22UF	10% 16V	CN3004	* 1-764-007-11	PIN, CONNECTOR (SMD) 12P	
C4013	1-164-156-11	CERAMIC CHIP 0.1UF	25V	CN3005	1-770-629-21	PIN, CONNECTOR 12P	
C4015	1-127-715-91	CERAMIC CHIP 0.22UF	10% 16V	CN3006	1-770-629-21	PIN, CONNECTOR 12P	
C4018	1-127-715-91	CERAMIC CHIP 0.22UF	10% 16V	CN3007	1-770-621-21	PIN, CONNECTOR 4P	
C4020	1-127-715-91	CERAMIC CHIP 0.22UF	10% 16V	CN3008	* 1-766-376-11	PIN, CONNECTOR (1.5MM) (SMD) 9P	
C4021	1-164-156-11	CERAMIC CHIP 0.1UF	25V	CN3009	1-766-382-21	PIN, CONNECTOR (1.5MM) (SMD) 10P	
C4022	1-164-156-11	CERAMIC CHIP 0.1UF	25V			< DIODE >	
C4023	1-164-156-11	CERAMIC CHIP 0.1UF	25V	D3001	8-719-050-37	DIODE M1MA152WA-T1	
C4024	1-164-156-11	CERAMIC CHIP 0.1UF	25V	D3007	8-719-041-97	DIODE MA113-(TX)	
C4025	1-164-156-11	CERAMIC CHIP 0.1UF	25V			< FERRITE BEAD >	
C4026	1-164-156-11	CERAMIC CHIP 0.1UF	25V	FB2010	1-414-921-11	FERRITE 0UH	
C4028	1-165-176-11	CERAMIC CHIP 0.047UF	10.00% 16V	FB2012	1-414-921-11	FERRITE 0UH	
C4030	1-165-176-11	CERAMIC CHIP 0.047UF	10.00% 16V	FB2015	1-414-921-11	FERRITE 0UH	
C4032	1-165-176-11	CERAMIC CHIP 0.047UF	10.00% 16V	FB2501	1-414-921-11	FERRITE 0UH	
C4033	1-164-156-11	CERAMIC CHIP 0.1UF	25V	FB2502	1-414-921-11	FERRITE 0UH	
C4035	1-164-156-11	CERAMIC CHIP 0.1UF	25V	FB2504	1-414-921-11	FERRITE 0UH	
C4036	1-165-176-11	CERAMIC CHIP 0.047UF	10.00% 16V	FB2505	1-414-921-11	FERRITE 0UH	
C4039	1-164-156-11	CERAMIC CHIP 0.1UF	25V	FB2506	1-414-921-11	FERRITE 0UH	
C4040	1-164-156-11	CERAMIC CHIP 0.1UF	25V	FB2601	1-414-921-11	FERRITE 0UH	
C4041	1-164-156-11	CERAMIC CHIP 0.1UF	25V	FB2602	1-414-921-11	FERRITE 0UH	
C4042	1-164-156-11	CERAMIC CHIP 0.1UF	25V	FB2603	1-414-921-11	FERRITE 0UH	
C4043	1-164-156-11	CERAMIC CHIP 0.1UF	25V	FB2604	1-414-921-11	FERRITE 0UH	
C4044	1-164-156-11	CERAMIC CHIP 0.1UF	25V	FB2651	1-414-921-11	FERRITE 0UH	
C4045	1-164-156-11	CERAMIC CHIP 0.1UF	25V	FB2653	1-414-921-11	FERRITE 0UH	
C4048	1-128-992-21	ELECT CHIP 47UF	20% 25V	FB2654	1-414-921-11	FERRITE 0UH	
C4049	1-165-176-11	CERAMIC CHIP 0.047UF	10.00% 16V	FB2701	1-414-921-11	FERRITE 0UH	
C4050	1-165-176-11	CERAMIC CHIP 0.047UF	10.00% 16V	FB2702	1-414-921-11	FERRITE 0UH	
C4051	1-128-992-21	ELECT CHIP 47UF	20% 25V	FB2704	1-414-921-11	FERRITE 0UH	
C4052	1-128-992-21	ELECT CHIP 47UF	20% 25V			< FILTER >	
C4053	1-127-715-91	CERAMIC CHIP 0.22UF	10% 16V	FL3001	1-233-830-11	FERRITE 37UH	
C4054	1-127-715-91	CERAMIC CHIP 0.22UF	10% 16V	FL3002	1-233-830-11	FERRITE 37UH	
C4068	1-162-927-11	CERAMIC CHIP 100PF	5.00% 50V	FL3003	1-233-830-11	FERRITE 37UH	
C4069	1-124-779-00	ELECT CHIP 10UF	20.00% 16V	FL3004	1-233-830-11	FERRITE 37UH	
C4070	1-124-779-00	ELECT CHIP 10UF	20.00% 16V	FL3005	1-233-830-11	FERRITE 37UH	
C4071	1-124-779-00	ELECT CHIP 10UF	20.00% 16V	FL3006	1-233-830-11	FERRITE 37UH	
C4077	1-124-779-00	ELECT CHIP 10UF	20.00% 16V	FL3007	1-233-830-11	FERRITE 37UH	
C4078	1-124-779-00	ELECT CHIP 10UF	20.00% 16V	FL3008	1-233-830-11	FERRITE 37UH	
C4079	1-124-779-00	ELECT CHIP 10UF	20.00% 16V			< IC >	
C4080	1-164-156-11	CERAMIC CHIP 0.1UF	25V	IC2006	8-759-490-41	IC TC74VHCT541AFT(EL)	
C4086	1-107-826-11	CERAMIC CHIP 0.1UF	10.00% 16V	IC2007	8-759-490-41	IC TC74VHCT541AFT(EL)	
C4090	1-107-826-11	CERAMIC CHIP 0.1UF	10.00% 16V	IC2009	8-759-442-07	IC LM75CIMX-5	
C4091	1-162-927-11	CERAMIC CHIP 100PF	5.00% 50V	IC2011	8-759-672-80	IC M24C02-MN6T(A)	
		< CONNECTOR >		IC2012	8-759-042-02	IC S-80743AL-A7-S	
CN2551	1-794-823-11	CONNECTOR (ZIF), FPC/FFC 32P		IC2501	8-752-106-13	IC CXA7001R-T6	
CN2601	1-794-823-11	CONNECTOR (ZIF), FPC/FFC 32P		IC2601	8-752-106-13	IC CXA7001R-T6	
CN2651	1-794-823-11	CONNECTOR (ZIF), FPC/FFC 32P					
CN3002	* 1-760-388-11	CONNECTOR PIN (SMD) 9P					
CN3003	* 1-695-223-21	PIN, CONNECTOR (SMD) 10P					



REF.NO.	PART.NO	DESCRIPTION	REMARK	REF.NO.	PART.NO	DESCRIPTION	REMARK
IC2701	8-752-106-13	IC CXA7001R-T6		L3105	1-412-029-11	INDUCTOR	10UH
IC2801	8-759-388-31	IC PQ20VZ1U		L3106	1-412-029-11	INDUCTOR	10UH
IC3003	8-759-196-93	IC TC7SH00FU-TE85R		L3107	1-412-029-11	INDUCTOR	10UH
IC3004	6-803-215-01	IC DPS9450AA1T		L3108	1-412-029-11	INDUCTOR	10UH
IC3005	8-759-926-98	IC SN74HC4040ANS		L3109	1-412-029-11	INDUCTOR	10UH
IC3006	8-752-072-94	IC CXA1875AM-T4		L4000	1-412-029-11	INDUCTOR	10UH
IC3007	8-759-387-54	IC S-80727-SN-DQ-T1		L4001	1-412-028-11	INDUCTOR	4.7UH
IC3008	8-759-669-75	IC TLC2932IPWR		L4002	1-412-028-11	INDUCTOR	4.7UH
IC3101	8-759-387-54	IC S-80727-SN-DQ-T1		L4003	1-412-029-11	INDUCTOR	10UH
IC3102	6-702-985-01	IC M24256-BWMN6T		L4004	1-469-525-91	INDUCTOR	10UH
IC3103	6-702-974-01	IC CXD9671GG		L4005	1-469-525-91	INDUCTOR	10UH
IC4000	6-803-214-01	IC VSP9427BC3T		L4006	1-469-525-91	INDUCTOR	10UH
IC4003	6-704-465-01	IC MC74LVX8053DTR2					
		< COIL >					
L2004	1-414-754-11	INDUCTOR	10UH	Q2001	8-729-422-33	TRANSISTOR 2SD601A-Q-TX	
L2501	1-414-754-11	INDUCTOR	10UH	Q2002	8-729-027-23	TRANSISTOR DTA114EKA-T146	
L2502	1-414-754-11	INDUCTOR	10UH	Q2502	8-729-013-28	TRANSISTOR HN1B01FU-TE85R	
L2504	1-414-754-11	INDUCTOR	10UH	Q2504	8-729-013-28	TRANSISTOR HN1B01FU-TE85R	
L2505	1-414-754-11	INDUCTOR	10UH	Q2602	8-729-013-28	TRANSISTOR HN1B01FU-TE85R	
L2506	1-414-754-11	INDUCTOR	10UH	Q2604	8-729-013-28	TRANSISTOR HN1B01FU-TE85R	
L2601	1-414-754-11	INDUCTOR	10UH	Q2702	8-729-013-28	TRANSISTOR HN1B01FU-TE85R	
L2602	1-414-754-11	INDUCTOR	10UH	Q2704	8-729-013-28	TRANSISTOR HN1B01FU-TE85R	
L2603	1-414-754-11	INDUCTOR	10UH	Q3001	8-729-028-28	TRANSISTOR 2SK2036 (TE85L)	
L2604	1-414-754-11	INDUCTOR	10UH	Q3002	8-729-028-28	TRANSISTOR 2SK2036 (TE85L)	
L2605	1-414-754-11	INDUCTOR	10UH	Q3004	8-729-026-49	TRANSISTOR 2SA1037AK-T146-R	
L2651	1-414-754-11	INDUCTOR	10UH	Q3101	8-729-422-33	TRANSISTOR 2SD601A-Q-TX	
L2652	1-414-754-11	INDUCTOR	10UH	Q3102	8-729-027-23	TRANSISTOR DTA114EKA-T146	
L2701	1-414-754-11	INDUCTOR	10UH	Q3105	8-729-900-53	TRANSISTOR DTC114EK	
L2702	1-414-754-11	INDUCTOR	10UH	Q4000	8-729-013-28	TRANSISTOR HN1B01FU-TE85R	
L2704	1-414-754-11	INDUCTOR	10UH	Q4001	8-729-013-28	TRANSISTOR HN1B01FU-TE85R	
L3001	1-409-556-11	INDUCTOR	47UH	Q4002	8-729-013-28	TRANSISTOR HN1B01FU-TE85R	
L3003	1-409-556-11	INDUCTOR	47UH	Q4003	8-729-422-33	TRANSISTOR 2SD601A-Q-TX	
L3004	1-409-556-11	INDUCTOR	47UH	Q4004	8-729-422-33	TRANSISTOR 2SD601A-Q-TX	
L3005	1-409-556-11	INDUCTOR	47UH	Q4005	8-729-422-33	TRANSISTOR 2SD601A-Q-TX	
L3009	1-409-556-11	INDUCTOR	47UH	Q4006	8-729-422-33	TRANSISTOR 2SD601A-Q-TX	
L3010	1-409-556-11	INDUCTOR	47UH	Q4007	8-729-422-33	TRANSISTOR 2SD601A-Q-TX	
L3011	1-409-556-11	INDUCTOR	47UH	Q4008	8-729-422-33	TRANSISTOR 2SD601A-Q-TX	
L3012	1-409-556-11	INDUCTOR	47UH	Q4009	8-729-422-33	TRANSISTOR 2SD601A-Q-TX	
L3013	1-412-029-11	INDUCTOR	10UH	Q4010	8-729-422-33	TRANSISTOR 2SD601A-Q-TX	
L3014	1-412-028-11	INDUCTOR	4.7UH	Q4011	8-729-422-33	TRANSISTOR 2SD601A-Q-TX	
L3015	1-412-028-11	INDUCTOR	4.7UH	Q4012	8-729-422-33	TRANSISTOR 2SD601A-Q-TX	
L3016	1-412-029-11	INDUCTOR	10UH	Q4013	8-729-013-28	TRANSISTOR HN1B01FU-TE85R	
L3017	1-412-029-11	INDUCTOR	10UH	Q4014	8-729-013-28	TRANSISTOR HN1B01FU-TE85R	
L3018	1-412-029-11	INDUCTOR	10UH	Q4015	8-729-013-28	TRANSISTOR HN1B01FU-TE85R	
L3019	1-412-058-11	INDUCTOR	10UH	Q4016	8-729-422-33	TRANSISTOR 2SD601A-Q-TX	
L3101	1-412-029-11	INDUCTOR	10UH	Q4017	8-729-422-33	TRANSISTOR 2SD601A-Q-TX	
L3102	1-412-029-11	INDUCTOR	10UH				
L3103	1-412-029-11	INDUCTOR	10UH				
L3104	1-412-029-11	INDUCTOR	10UH				
						< RESISTOR >	
				JR4000	1-216-864-11	SHORT CHIP	0

REF.NO.	PART.NO	DESCRIPTION	REMARK	REF.NO.	PART.NO	DESCRIPTION	REMARK
JR4001	1-216-864-11	SHORT CHIP	0	R2525	1-216-864-11	SHORT CHIP	0
JR4004	1-216-864-11	SHORT CHIP	0	R2526	1-216-864-11	SHORT CHIP	0
JR4005	1-216-864-11	SHORT CHIP	0	R2529	1-218-867-11	METAL CHIP	6.8K 0.5% 1/10W
JR4007	1-216-864-11	SHORT CHIP	0	R2530	1-218-712-11	METAL CHIP	6.8K 0.5% 1/10W
R2059	1-216-864-11	SHORT CHIP	0	R2532	1-218-702-11	METAL CHIP	2.7K 0.5% 1/10W
R2060	1-216-809-11	METAL CHIP	100 5% 1/10W	R2537	1-216-804-11	METAL CHIP	39 5% 1/10W
R2061	1-216-809-11	METAL CHIP	100 5% 1/10W	R2538	1-216-804-11	METAL CHIP	39 5% 1/10W
R2062	1-216-809-11	METAL CHIP	100 5% 1/10W	R2541	1-216-797-11	METAL CHIP	10 5% 1/10W
R2063	1-216-864-11	SHORT CHIP	0	R2543	1-216-825-11	METAL CHIP	2.2K 5% 1/10W
R2064	1-216-797-11	METAL CHIP	10 5% 1/10W	R2545	1-216-825-11	METAL CHIP	2.2K 5% 1/10W
R2065	1-216-797-11	METAL CHIP	10 5% 1/10W	R2548	1-216-789-11	METAL CHIP	2.2 5% 1/10W
R2066	1-216-797-11	METAL CHIP	10 5% 1/10W	R2549	1-216-789-11	METAL CHIP	2.2 5% 1/10W
R2067	1-216-797-11	METAL CHIP	10 5% 1/10W	R2553	1-216-797-11	METAL CHIP	10 5% 1/10W
R2073	1-216-805-11	METAL CHIP	47 5% 1/10W	R2601	1-216-833-11	METAL CHIP	10K 5% 1/10W
R2074	1-216-805-11	METAL CHIP	47 5% 1/10W	R2602	1-216-864-11	SHORT CHIP	0
R2077	1-216-864-11	SHORT CHIP	0	R2603	1-216-833-11	METAL CHIP	10K 5% 1/10W
R2078	1-216-864-11	SHORT CHIP	0	R2604	1-216-813-11	METAL CHIP	220 5% 1/10W
R2079	1-216-864-11	SHORT CHIP	0	R2605	1-216-864-11	SHORT CHIP	0
R2080	1-216-805-11	METAL CHIP	47 5% 1/10W	R2606	1-216-805-11	METAL CHIP	47 5% 1/10W
R2081	1-216-805-11	METAL CHIP	47 5% 1/10W	R2607	1-216-805-11	METAL CHIP	47 5% 1/10W
R2087	1-216-833-11	METAL CHIP	10K 5% 1/10W	R2608	1-216-864-11	SHORT CHIP	0
R2088	1-216-833-11	METAL CHIP	10K 5% 1/10W	R2611	1-216-864-11	SHORT CHIP	0
R2089	1-216-825-11	METAL CHIP	2.2K 5% 1/10W	R2612	1-216-864-11	SHORT CHIP	0
R2090	1-216-864-11	SHORT CHIP	0	R2613	1-216-864-11	SHORT CHIP	0
R2091	1-216-864-11	SHORT CHIP	0	R2614	1-218-877-11	METAL CHIP	18K 0.5% 1/10W
R2092	1-216-864-11	SHORT CHIP	0	R2615	1-218-861-11	METAL CHIP	3.9K 0.5% 1/10W
R2093	1-216-864-11	SHORT CHIP	0	R2617	1-218-863-11	METAL CHIP	4.7K 0.5% 1/10W
R2094	1-216-797-11	METAL CHIP	10 5% 1/10W	R2618	1-218-863-11	METAL CHIP	4.7K 0.5% 1/10W
R2095	1-216-797-11	METAL CHIP	10 5% 1/10W	R2619	1-218-853-11	METAL CHIP	1.8K 0.5% 1/10W
R2501	1-216-833-11	METAL CHIP	10K 5% 1/10W	R2620	1-216-864-11	SHORT CHIP	0
R2502	1-216-864-11	SHORT CHIP	0	R2621	1-216-864-11	SHORT CHIP	0
R2503	1-216-833-11	METAL CHIP	10K 5% 1/10W	R2624	1-216-833-11	METAL CHIP	10K 5% 1/10W
R2504	1-216-813-11	METAL CHIP	220 5% 1/10W	R2625	1-216-864-11	SHORT CHIP	0
R2505	1-216-805-11	METAL CHIP	47 5% 1/10W	R2626	1-216-864-11	SHORT CHIP	0
R2506	1-216-805-11	METAL CHIP	47 5% 1/10W	R2627	1-216-864-11	SHORT CHIP	0
R2507	1-216-864-11	SHORT CHIP	0	R2630	1-218-712-11	METAL CHIP	6.8K 0.5% 1/10W
R2508	1-216-864-11	SHORT CHIP	0	R2632	1-218-702-11	METAL CHIP	2.7K 0.5% 1/10W
R2510	1-216-864-11	SHORT CHIP	0	R2633	1-216-804-11	METAL CHIP	39 5% 1/10W
R2511	1-216-864-11	SHORT CHIP	0	R2634	1-216-804-11	METAL CHIP	39 5% 1/10W
R2512	1-216-864-11	SHORT CHIP	0	R2635	1-218-867-11	METAL CHIP	6.8K 0.5% 1/10W
R2513	1-218-877-11	METAL CHIP	18K 0.5% 1/10W	R2636	1-218-871-11	METAL CHIP	10K 0.5% 1/10W
R2514	1-218-861-11	METAL CHIP	3.9K 0.5% 1/10W	R2638	1-218-863-11	METAL CHIP	4.7K 0.5% 1/10W
R2516	1-218-863-11	METAL CHIP	4.7K 0.5% 1/10W	R2642	1-216-797-11	METAL CHIP	10 5% 1/10W
R2517	1-218-863-11	METAL CHIP	4.7K 0.5% 1/10W	R2644	1-216-825-11	METAL CHIP	2.2K 5% 1/10W
R2519	1-218-853-11	METAL CHIP	1.8K 0.5% 1/10W	R2646	1-216-825-11	METAL CHIP	2.2K 5% 1/10W
R2520	1-216-864-11	SHORT CHIP	0	R2649	1-216-789-11	METAL CHIP	2.2 5% 1/10W
R2521	1-216-864-11	SHORT CHIP	0	R2650	1-216-789-11	METAL CHIP	2.2 5% 1/10W
R2523	1-216-833-11	METAL CHIP	10K 5% 1/10W	R2656	1-216-797-11	METAL CHIP	10 5% 1/10W
R2524	1-216-864-11	SHORT CHIP	0	R2701	1-216-833-11	METAL CHIP	10K 5% 1/10W
				R2702	1-216-864-11	SHORT CHIP	0

REF.NO.	PART.NO	DESCRIPTION	REMARK			REF.NO.	PART.NO	DESCRIPTION	REMARK		
R2703	1-216-833-11	METAL CHIP	10K	5%	1/10W	R3032	1-216-809-11	METAL CHIP	100	5%	1/10W
R2704	1-216-805-11	METAL CHIP	47	5%	1/10W	R3033	1-216-809-11	METAL CHIP	100	5%	1/10W
R2705	1-216-805-11	METAL CHIP	47	5%	1/10W	R3039	1-216-809-11	METAL CHIP	100	5%	1/10W
R2706	1-216-864-11	SHORT CHIP	0			R3040	1-216-809-11	METAL CHIP	100	5%	1/10W
R2707	1-216-864-11	SHORT CHIP	0			R3041	1-216-821-91	RES CHIP	1K	5%	1/10W
R2709	1-216-864-11	SHORT CHIP	0			R3042	1-216-829-11	METAL CHIP	4.7K	5%	1/10W
R2710	1-216-864-11	SHORT CHIP	0			R3043	1-216-864-11	SHORT CHIP	0		
R2711	1-216-864-11	SHORT CHIP	0			R3044	1-216-864-11	SHORT CHIP	0		
R2712	1-218-877-11	METAL CHIP	18K	0.5%	1/10W	R3045	1-216-864-11	SHORT CHIP	0		
R2713	1-218-861-11	METAL CHIP	3.9K	0.5%	1/10W	R3046	1-216-864-11	SHORT CHIP	0		
R2715	1-218-863-11	METAL CHIP	4.7K	0.5%	1/10W	R3047	1-216-864-11	SHORT CHIP	0		
R2716	1-218-863-11	METAL CHIP	4.7K	0.5%	1/10W	R3048	1-216-864-11	SHORT CHIP	0		
R2717	1-218-853-11	METAL CHIP	1.8K	0.5%	1/10W	R3049	1-216-864-11	SHORT CHIP	0		
R2718	1-216-864-11	SHORT CHIP	0			R3051	1-216-857-11	METAL CHIP	1M	5%	1/10W
R2719	1-216-864-11	SHORT CHIP	0			R3052	1-216-864-11	SHORT CHIP	0		
R2722	1-216-833-11	METAL CHIP	10K	5%	1/10W	R3053	1-216-864-11	SHORT CHIP	0		
R2723	1-216-864-11	SHORT CHIP	0			R3054	1-216-864-11	SHORT CHIP	0		
R2724	1-216-864-11	SHORT CHIP	0			R3055	1-216-864-11	SHORT CHIP	0		
R2725	1-216-864-11	SHORT CHIP	0			R3058	1-218-847-11	METAL CHIP	1K	0.5%	1/10W
R2728	1-216-804-11	METAL CHIP	39	5%	1/10W	R3060	1-216-864-11	SHORT CHIP	0		
R2729	1-216-804-11	METAL CHIP	39	5%	1/10W	R3062	1-218-823-11	METAL CHIP	100	0.5%	1/10W
R2730	1-218-712-11	METAL CHIP	6.8K	0.5%	1/10W	R3063	1-216-864-11	SHORT CHIP	0		
R2732	1-218-702-11	METAL CHIP	2.7K	0.5%	1/10W	R3066	1-216-864-11	SHORT CHIP	0		
R2733	1-218-867-11	METAL CHIP	6.8K	0.5%	1/10W	R3067	1-216-864-11	SHORT CHIP	0		
R2740	1-216-797-11	METAL CHIP	10	5%	1/10W	R3068	1-216-821-11	METAL CHIP	1K	5%	1/10W
R2742	1-216-825-11	METAL CHIP	2.2K	5%	1/10W	R3070	1-216-821-11	METAL CHIP	1K	5%	1/10W
R2744	1-216-825-11	METAL CHIP	2.2K	5%	1/10W	R3072	1-216-825-11	METAL CHIP	2.2K	5%	1/10W
R2747	1-216-789-11	METAL CHIP	2.2	5%	1/10W	R3074	1-216-864-11	SHORT CHIP	0		
R2748	1-216-789-11	METAL CHIP	2.2	5%	1/10W	R3075	1-216-855-11	METAL CHIP	680K	5%	1/10W
R2750	1-216-797-11	METAL CHIP	10	5%	1/10W	R3076	1-218-835-11	METAL CHIP	330	0.5%	1/10W
R2751	1-216-813-11	METAL CHIP	220	5%	1/10W	R3077	1-218-835-11	METAL CHIP	330	0.5%	1/10W
R2801	1-218-871-11	METAL CHIP	10K	0.5%	1/10W	R3079	1-216-855-11	METAL CHIP	680K	5%	1/10W
R2802	1-218-847-11	METAL CHIP	1K	0.5%	1/10W	R3080	1-216-820-11	METAL CHIP	820	5%	1/10W
R2803	1-216-864-11	SHORT CHIP	0			R3082	1-216-864-11	SHORT CHIP	0		
R3006	1-216-833-11	METAL CHIP	10K	5%	1/10W	R3101	1-216-841-11	METAL CHIP	47K	5%	1/10W
R3007	1-216-833-11	METAL CHIP	10K	5%	1/10W	R3102	1-216-819-11	METAL CHIP	680	5%	1/10W
R3008	1-216-809-11	METAL CHIP	100	5%	1/10W	R3104	1-216-833-11	METAL CHIP	10K	5%	1/10W
R3009	1-216-809-11	METAL CHIP	100	5%	1/10W	R3106	1-216-833-11	METAL CHIP	10K	5%	1/10W
R3010	1-216-864-11	SHORT CHIP	0			R3107	1-216-805-11	METAL CHIP	47	5%	1/10W
R3011	1-216-864-11	SHORT CHIP	0			R3109	1-216-833-11	METAL CHIP	10K	5%	1/10W
R3012	1-216-864-11	SHORT CHIP	0			R3110	1-216-833-11	METAL CHIP	10K	5%	1/10W
R3018	1-216-809-11	METAL CHIP	100	5%	1/10W	R3111	1-216-805-11	METAL CHIP	47	5%	1/10W
R3020	1-216-864-11	SHORT CHIP	0			R3113	1-216-833-11	METAL CHIP	10K	5%	1/10W
R3021	1-216-864-11	SHORT CHIP	0			R3118	1-216-833-11	METAL CHIP	10K	5%	1/10W
R3023	1-216-829-11	METAL CHIP	4.7K	5%	1/10W	R3119	1-216-833-11	METAL CHIP	10K	5%	1/10W
R3024	1-216-829-11	METAL CHIP	4.7K	5%	1/10W	R3120	1-216-833-11	METAL CHIP	10K	5%	1/10W
R3025	1-216-864-11	SHORT CHIP	0			R3121	1-216-864-11	SHORT CHIP	0		
R3028	1-218-867-11	METAL CHIP	6.8K	0.5%	1/10W	R3122	1-216-864-11	SHORT CHIP	0		
R3029	1-216-833-11	METAL CHIP	10K	5%	1/10W	R3123	1-216-864-11	SHORT CHIP	0		
R3031	1-216-809-11	METAL CHIP	100	5%	1/10W	R3124	1-216-864-11	SHORT CHIP	0		



REF.NO.	PART.NO	DESCRIPTION	REMARK			REF.NO.	PART.NO	DESCRIPTION	REMARK		
R3125	1-216-864-11	SHORT CHIP	0			R4019	1-218-732-11	METAL CHIP	47K	0.5%	1/10W
R3126	1-216-833-11	METAL CHIP	10K	5%	1/10W	R4020	1-218-732-11	METAL CHIP	47K	0.5%	1/10W
R3127	1-216-864-11	SHORT CHIP	0			R4021	1-218-732-11	METAL CHIP	47K	0.5%	1/10W
R3128	1-216-833-11	METAL CHIP	10K	5%	1/10W	R4022	1-216-814-11	METAL CHIP	270	5%	1/10W
R3129	1-216-833-11	METAL CHIP	10K	5%	1/10W	R4023	1-216-809-11	METAL CHIP	100	5%	1/10W
R3130	1-216-833-11	METAL CHIP	10K	5%	1/10W	R4024	1-216-814-11	METAL CHIP	270	5%	1/10W
R3131	1-216-833-11	METAL CHIP	10K	5%	1/10W	R4025	1-216-814-11	METAL CHIP	270	5%	1/10W
R3132	1-216-864-11	SHORT CHIP	0			R4026	1-216-864-11	SHORT CHIP	0		
R3133	1-216-864-11	SHORT CHIP	0			R4027	1-216-809-11	METAL CHIP	100	5%	1/10W
R3134	1-216-864-11	SHORT CHIP	0			R4028	1-216-864-11	SHORT CHIP	0		
R3135	1-216-864-11	SHORT CHIP	0			R4029	1-216-864-11	SHORT CHIP	0		
R3136	1-216-864-11	SHORT CHIP	0			R4030	1-216-864-11	SHORT CHIP	0		
R3137	1-216-864-11	SHORT CHIP	0			R4031	1-216-864-11	SHORT CHIP	0		
R3138	1-216-864-11	SHORT CHIP	0			R4032	1-216-833-11	METAL CHIP	10K	5%	1/10W
R3139	1-216-864-11	SHORT CHIP	0			R4033	1-216-864-11	SHORT CHIP	0		
R3140	1-216-864-11	SHORT CHIP	0			R4034	1-216-864-11	SHORT CHIP	0		
R3141	1-216-864-11	SHORT CHIP	0			R4035	1-216-864-11	SHORT CHIP	0		
R3142	1-216-864-11	SHORT CHIP	0			R4036	1-216-814-11	METAL CHIP	270	5%	1/10W
R3143	1-216-864-11	SHORT CHIP	0			R4039	1-216-864-11	SHORT CHIP	0		
R3144	1-216-864-11	SHORT CHIP	0			R4040	1-216-814-11	METAL CHIP	270	5%	1/10W
R3145	1-216-805-11	METAL CHIP	47	5%	1/10W	R4042	1-216-864-11	SHORT CHIP	0		
R3146	1-216-805-11	METAL CHIP	47	5%	1/10W	R4043	1-216-814-11	METAL CHIP	270	5%	1/10W
R3147	1-216-801-11	METAL CHIP	22	5%	1/10W	R4044	1-216-809-11	METAL CHIP	100	5%	1/10W
R3148	1-216-801-11	METAL CHIP	22	5%	1/10W	R4046	1-216-849-11	METAL CHIP	220K	5%	1/10W
R3149	1-216-864-11	SHORT CHIP	0			R4047	1-216-805-11	METAL CHIP	47	5%	1/10W
R3150	1-216-807-11	METAL CHIP	68	5%	1/10W	R4048	1-216-833-11	METAL CHIP	10K	5%	1/10W
R3151	1-216-801-11	METAL CHIP	22	5%	1/10W	R4049	1-216-821-11	METAL CHIP	1K	5%	1/10W
R3152	1-216-807-11	METAL CHIP	68	5%	1/10W	R4050	1-218-732-11	METAL CHIP	47K	0.5%	1/10W
R3153	1-216-801-11	METAL CHIP	22	5%	1/10W	R4051	1-218-732-11	METAL CHIP	47K	0.5%	1/10W
R3154	1-216-807-11	METAL CHIP	68	5%	1/10W	R4052	1-216-841-11	METAL CHIP	47K	5%	1/10W
R3155	1-216-807-11	METAL CHIP	68	5%	1/10W	R4053	1-216-841-11	METAL CHIP	47K	5%	1/10W
R3171	1-216-864-11	SHORT CHIP	0			R4054	1-216-841-11	METAL CHIP	47K	5%	1/10W
R3176	1-216-829-11	METAL CHIP	4.7K	5%	1/10W	R4055	1-216-841-11	METAL CHIP	47K	5%	1/10W
R4001	1-216-864-11	SHORT CHIP	0			R4056	1-216-841-11	METAL CHIP	47K	5%	1/10W
R4002	1-216-864-11	SHORT CHIP	0			R4057	1-216-841-11	METAL CHIP	47K	5%	1/10W
R4003	1-216-864-11	SHORT CHIP	0			R4058	1-216-821-11	METAL CHIP	1K	5%	1/10W
R4004	1-216-864-11	SHORT CHIP	0			R4059	1-216-833-11	METAL CHIP	10K	5%	1/10W
R4005	1-216-864-11	SHORT CHIP	0			R4060	1-216-817-11	METAL CHIP	470	5%	1/10W
R4006	1-218-732-11	METAL CHIP	47K	0.5%	1/10W	R4061	1-216-864-11	SHORT CHIP	0		
R4007	1-218-732-11	METAL CHIP	47K	0.5%	1/10W	R4062	1-216-864-11	SHORT CHIP	0		
R4008	1-216-841-11	METAL CHIP	47K	5%	1/10W	R4065	1-216-833-11	METAL CHIP	10K	5%	1/10W
R4009	1-216-864-11	SHORT CHIP	0			R4066	1-216-864-11	SHORT CHIP	0		
R4010	1-216-864-11	SHORT CHIP	0			R4067	1-216-864-11	SHORT CHIP	0		
R4011	1-216-864-11	SHORT CHIP	0			R4068	1-216-864-11	SHORT CHIP	0		
R4012	1-216-841-11	METAL CHIP	47K	5%	1/10W	R4069	1-216-864-11	SHORT CHIP	0		
R4013	1-218-732-11	METAL CHIP	47K	0.5%	1/10W			< RESISTOR CHIP >			
R4014	1-216-864-11	SHORT CHIP	0			RB2013	1-233-796-11	RES, NETWORK			(1608)
R4015	1-216-864-11	SHORT CHIP	0			RB2501	1-233-574-11	RES, CHIP NETWORK	10		
R4016	1-216-864-11	SHORT CHIP	0			RB2502	1-233-574-11	RES, CHIP NETWORK	10		
R4018	1-216-864-11	SHORT CHIP	0								

Note : The components identified by shading and marked Δ are critical for safety. Replace only with the part numbers specified in the parts list.

C

REF.NO.	PART.NO	DESCRIPTION	REMARK	REF.NO.	PART.NO	DESCRIPTION	REMARK
RB2503	1-233-574-11	RES, CHIP NETWORK 10		MISCELLANEOUS			
RB2553	1-233-782-91	RES, NETWORK 10	(1608)	1-825-580-11	LOUDSPEAKER (10CM)		
RB2601	1-233-782-91	RES, NETWORK 10	(1608)	1-544-857-11	SPEAKER (13X7CM)		
RB2602	1-233-574-11	RES, CHIP NETWORK 10		1-419-965-11	COIL, CHOKE 27.0MMH		
RB2603	1-233-574-11	RES, CHIP NETWORK 10		Δ 1-765-286-11	CORD, POWER (KF-50SX300K/KF50SX300AEP/ KF-60SX300K/KF-60SX300AEP)		
RB2604	1-233-574-11	RES, CHIP NETWORK 10		Δ 1-776-860-11	POWER CORD, FILTER(UK) (KF-50SX300U/ KF-60SX300U)		
RB2653	1-233-782-91	RES, NETWORK 10	(1608)	1-787-057-11	D.C.FAN		
RB2701	1-233-574-11	RES, CHIP NETWORK 10		1-418-257-11	FAN UNIT, DC		
RB2702	1-233-574-11	RES, CHIP NETWORK 10		8-598-535-20	FRONTEND BTF-EF411		
RB2703	1-233-574-11	RES, CHIP NETWORK 10		Δ 1-468-798-11	POWER SUPPLY BLOCK		
RB3002	1-234-370-21	RES, NETWORK 22X4	(1005)	ACCESSORIES AND PACKAGING MATERIALS			
RB3006	1-234-370-21	RES, NETWORK 22X4	(1005)	*4-055-672-01	BAG, PROTECTION		
RB3007	1-234-370-21	RES, NETWORK 22X4	(1005)	*4-087-938-01	JOINT		
RB3008	1-234-370-21	RES, NETWORK 22X4	(1005)	*4-096-845-01	INDIVIDUAL CARTON		
RB3009	1-234-370-21	RES, NETWORK 22X4	(1005)	*4-096-846-01	CUSHION UPPER ASSY		
RB3010	1-234-370-21	RES, NETWORK 22X4	(1005)	*4-096-847-01	CUSHION LOWER ASSY		
RB3102	1-233-784-91	RES, NETWORK 47	(1608)	*4-096-848-01	TRAY		
RB3104	1-233-789-11	RES, NETWORK 10K	(1608)	*4-099-708-01	TOP BOARD		
RB3105	1-234-372-21	RES, NETWORK 100X4	(1005)	*4-099-709-01	BOTTOM BOARD		
RB3106	1-233-785-91	RES, NETWORK 100	(1608)	X-404-937-01	PACKING ASSY REAR COVER (50)		
RB3107	1-234-372-21	RES, NETWORK 100X4	(1005)	X-096-824-01	SHEET, POLYTHENE		
RB3108	1-233-785-91	RES, NETWORK 100	(1608)	X-096-825-01	TOP, COVER		
RB3109	1-234-370-21	RES, NETWORK 22X4	(1005)	X-096-826-01	BASE TRAY		
RB3110	1-234-370-21	RES, NETWORK 22X4	(1005)	X-096-827-01	CARTON, SUB		
RB3111	1-234-372-21	RES, NETWORK 100X4	(1005)	X-096-824-01	HOLDER		
RB3112	1-233-785-91	RES, NETWORK 100	(1608)	4-096-858-11	INSTRUCTION MANUAL		
RB3113	1-234-372-21	RES, NETWORK 100X4	(1005)	4-096-858-11	INSTRUCTION MANUAL (ENGLISH/GERMAN/FRENCH/ ITALIAN/DUTCH/TURKISH)		
RB3114	1-234-372-21	RES, NETWORK 100X4	(1005)	4-096-858-21	INSTRUCTION MANUAL (DANISH/SPANISH/FINNISH/ NORWEGIAN/PORTUGUESE/SWEDISH)		
RB3115	1-234-372-21	RES, NETWORK 100X4	(1005)	4-096-858-31	INSTRUCTION MANUAL (ENGLISH)		
RB4000	1-234-372-21	RES, NETWORK 100X4	(1005)	4-096-858-41	INSTRUCTION MANUAL (ENGLISH/BULGARIAN/CZECH/ HUNGARIAN/POLISH/RUSSIAN)		
RB4001	1-234-372-21	RES, NETWORK 100X4	(1005)	REMOTE COMMANDER			
RB4002	1-234-372-21	RES, NETWORK 100X4	(1005)	1-478-285-11	REMOTE COMMANDER (RM-906)		
RB4003	1-234-372-21	RES, NETWORK 100X4	(1005)				
TP2012	1-535-757-11	CHIP, CHECKER					
TP2013	1-535-757-11	CHIP, CHECKER					
TP2014	1-535-757-11	CHIP, CHECKER					
TP2015	1-535-757-11	CHIP, CHECKER					
TP2016	1-535-757-11	CHIP, CHECKER					
TP2017	1-535-757-11	CHIP, CHECKER					
TP2018	1-535-757-11	CHIP, CHECKER					
TP2019	1-535-757-11	CHIP, CHECKER					
TP2020	1-535-757-11	CHIP, CHECKER					
TP2021	1-535-757-11	CHIP, CHECKER					
TP2024	1-535-757-11	CHIP, CHECKER					
TP2025	1-535-757-11	CHIP, CHECKER					
		< CRYSTAL >					
X3001	1-781-109-21	VIBRATOR, CRYSTAL					
X4000	1-781-109-21	VIBRATOR, CRYSTAL					

TRACE

A new TV Repair Assistance Tool that combines ease of use and powerful PC software tools to allow you to save valuable time during many TV repairs.



The TRACE interface connects to the PC's serial port. It provides connection to the TV's I²C bus and can be provided with an InfraRed transmitter (optional).

The interface is powered by a standard 9 V PP3 battery for portable use, and can also be powered by an external 9V/25mA DC power supply.

The TRACE software that is supplied with the interface allows you to:

- Read, restore and compare NVM contents via the I²C bus
- Acknowledge check of all I²C devices in the TV set
- Read Error Codes (emulation of the Error Reader tool)

With the optional IR Add-on kit, the following features can be added:

- Remote Commander emulation
- User programmable Functional Check through Infrared
- Fast and documented Test Mode setting of all Sony TV chassis

Additional features such as Adjustments and Troubleshooting are available in chassis-dependent software modules. Please contact your local Sony Service organisation for the latest information.

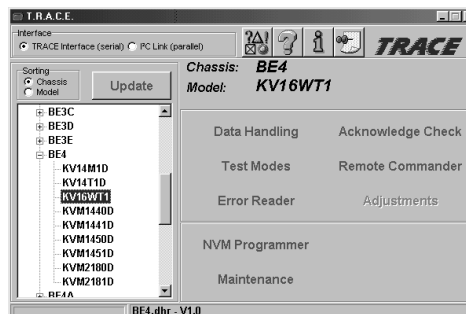

Note: For workshops already using the existing I²C Link parallel port interface (9-948-320-30), this software can be used as well, replacing the TV Data Handling software (9-948-340-50), but Error Reader and IR functions can only be accessed with the TRACE interface.

Partnumbers: TRACE Starter Kit (TRACE interface + software): 9-948-320-70
TRACE Software (for users of the I²C Link interface): 9-948-340-80
TRACE IR Add-on (IR interface + Remote Commander software): 9-948-320-80

PC requirements: IBM-compatible PC with operating system Windows95, Windows98, or WindowsNT*.

* WindowsNT only supported with TRACE interface